

Baxi Maxflow Combi FS

Gas Fired Floor Standing Combination Boiler
with Unvented Hot Water Storage

IMPORTANT: This boiler MUST be installed with the Unvented Kit Part No. 247369 which is in a separate box supplied with the boiler

Installation and Servicing Instructions

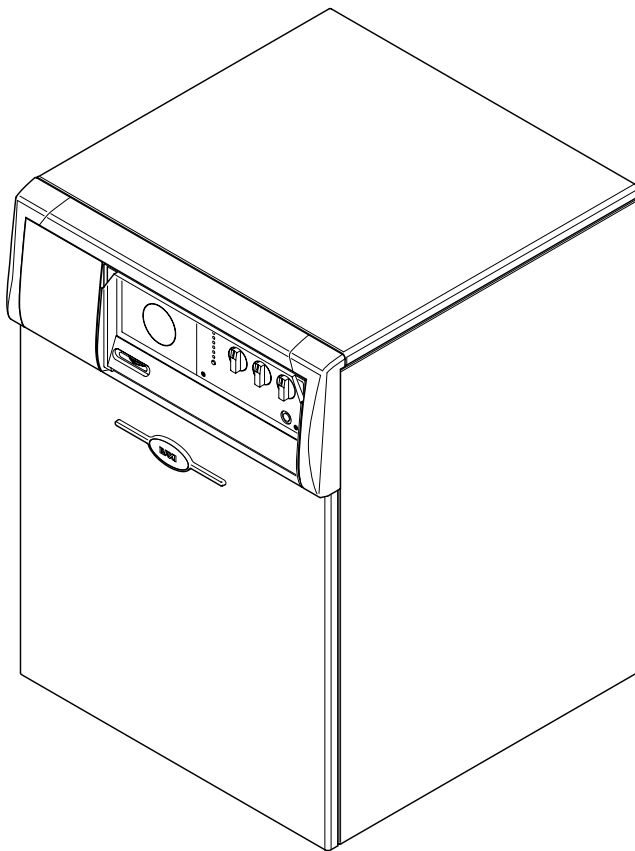

BAXI

Baxi Maxflow Combi FS
G.C.N° 47 075 10

Baxi UK Limited is one of the leading manufacturers of domestic heating products in the UK.

Our first priority is to give a high quality service to our customers. Quality is designed into every Baxi product - products which fulfil the demands and needs of customers, offering choice, efficiency and reliability.

To keep ahead of changing trends, we have made a commitment to develop new ideas using the latest technology - with the aim of continuing to make the products that customers want to buy.

Everyone who works at Baxi has a commitment to quality because we know that satisfied customers mean continued success.

We hope you get a satisfactory service from Baxi. If not, please let us know.

The boiler meets the requirements of Statutory Instrument “ The Boiler (Efficiency) Regulations 1993 N° 3083” and is deemed to meet the requirements of Directive 92/42/EEC on the energy efficiency requirements for new hot water boilers fired with liquid or gaseous fuels:-

Type test for purpose of Regulation 5 certified by:
Notified Body 0051.

Product/Production certified by:
Notified Body 0051.

For GB/IE only.



Baxi is a BS-EN ISO 9001
Accredited Company

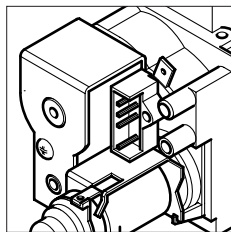
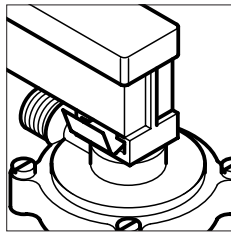
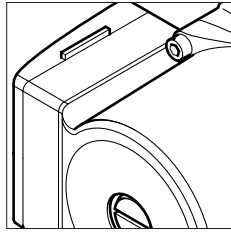

Contents

| Section | Page |
|---------------------------------|------|
| 1.0 Introduction | 4 |
| 2.0 General Layout | 5 |
| 3.0 Appliance Operation | 6 |
| 4.0 Technical Data | 7 |
| 5.0 Dimensions and Fixings | 8 |
| 6.0 System Details | 9 |
| 7.0 Site Requirements | 13 |
| 8.0 Installation | 18 |
| 9.0 Commissioning the Boiler | 24 |
| 10.0 Servicing the Boiler | 26 |
| 11.0 Changing Components | 28 |
| 12.0 Illustrated Wiring Diagram | 40 |
| 13.0 Fault Finding | 41 |
| 14.0 Short Parts List | 45 |

NOTE: This appliance must be installed in accordance with the manufacturer's instructions and the regulations in force. Read the instructions fully before installing or using the appliance.

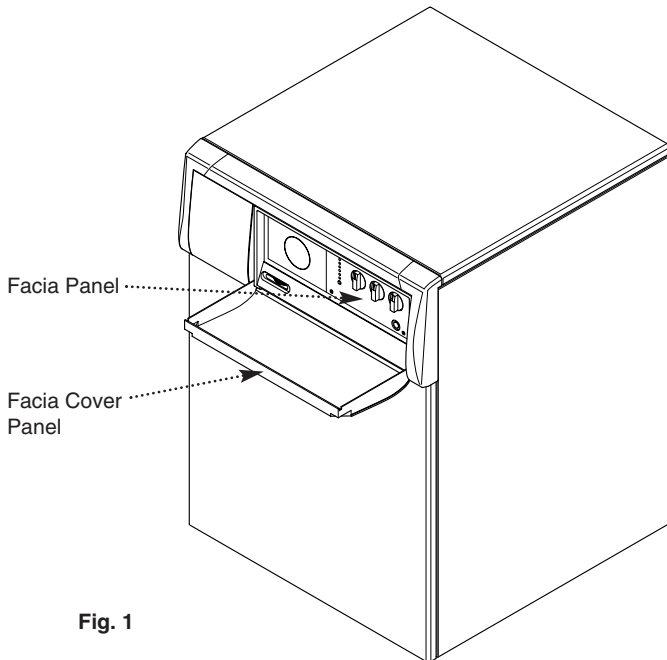

Fig. 1

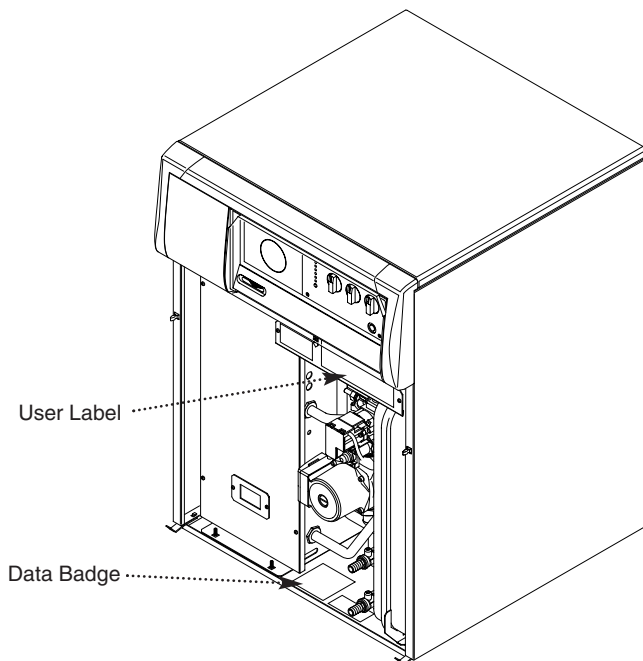

Fig. 2

“Benchmark” Log Book

As part of the industry-wide “Benchmark” initiative all Baxi boilers now include an Installation, Commissioning and Service Record Log Book. Please read the Log Book carefully and complete all sections relevant to the appliance and installation. These include sections on the type of controls employed, flushing the system, burner operating pressure etc. The details of the Log Book will be required in the event of any warranty work. Also, there is a section to be completed at each subsequent regular service visit. The Log Book must be left with the user.

1.0 Introduction

Baxi UK Limited declare that no substances harmful to health are contained in the appliance or used during appliance manufacture.

1.1 Description

1. The Baxi Maxflow Combi FS is a fully automatic gas fired floor standing combination boiler incorporating a 54 litre unvented hot water storage cylinder. It is room sealed and fan assisted.
2. The boiler is designed for use with a fully pumped, sealed and pressurised system and provides central heating and domestic hot water at mains pressure. It incorporates a pump, diverter valve, pressure relief valve, expansion vessel and pressure gauge.
3. The boiler is set to provide a maximum output of 28.0 kW. This modulates in both Central Heating and Domestic Hot Water modes depending on the setting of the temperature controls, the water temperature in the boiler and, in the case of Domestic Hot Water mode, the temperature of the stored water. See Section 3.1 for full details. The controls are behind the facia cover panel (Fig. 1).
4. The boiler has been approved to the Building Regulations for unvented hot water storage systems and the Local Authority must be informed of the intention to install.

IMPORTANT: The installation of unvented hot water storage systems and their components must only be carried out by suitably qualified personnel. Consideration should be given to Building Regulations document G3.

5. The components supplied in the box marked “Unvented Kit” **MUST** be fitted to the mains water supply in accordance with the instructions included.
6. It is designed for use on Natural Gas (G20) and can be converted to use Propane or Butane.
7. A label giving details of the model, serial number and Gas Council number is situated on the wiring cover panel (Fig. 2).
8. The boiler data badge is positioned on the boiler base panel (Fig. 2).
9. The boiler is intended to be installed in residential / commercial / light industrial E.M.C. environments on a governed meter supply only.
10. The boiler must be installed with one of the purpose designed flues such as the standard horizontal flue kit.
11. **All systems must be thoroughly flushed and treated with inhibitor (see section 6.2).**

1.2 Installation

1. The appliance is suitable for installation only in G.B. and I.E. and should be installed in accordance with the rules in force. For Ireland install in accordance with I.S.813 “Installation of Gas Appliances”. The installation must be carried out by a CORGI Registered Installer or other competent person and be in accordance with the relevant requirements of current Gas Safety (Installation and Use) Regulations, the Building Regulations (Scotland) (Consolidation), the Local Building Regulations, the Current I.E.E. Wiring Regulations and the bye laws of the Local Water Undertaking. Where no specific instructions are given, reference should be made to the relevant BRITISH STANDARD CODES OF PRACTICE.

2.0 General Layout

2.1 Layout

1. Central Heating Flow
2. Pressure Relief Valve
3. Central Heating Return
4. Domestic Hot Water Flow
5. Mains Water Inlet
6. Gas Inlet
7. Domestic Hot Water Storage Cylinder
8. Storage Cylinder Heating Coil
9. Expansion Vessel
10. Domestic Hot Water Storage Drain
11. Heating Coil Drain
12. Circulation Pump
13. Gas Valve
14. Burner
15. Heat Exchanger
16. Fan/Hood assembly
17. Air Pressure Switch
18. Electrical Cover Panel
19. Temperature Gauge
20. Position For Optional Integral Timer
21. Facia Cover Panel
22. Facia
23. Overheat Thermostat
24. Flow Temperature Sensor
25. Electrical Control Box
26. Temperature Gauge Sensor
27. Filling Loop Connections
28. Diverter Valve
29. Storage Cylinder Temperature Sensor
30. Indicator Neons
31. Domestic Hot Water Temperature Control
32. ON/OFF Selector Switch
33. Central Heating Temperature Control
34. Flame Failure Reset Button
35. Reset Button

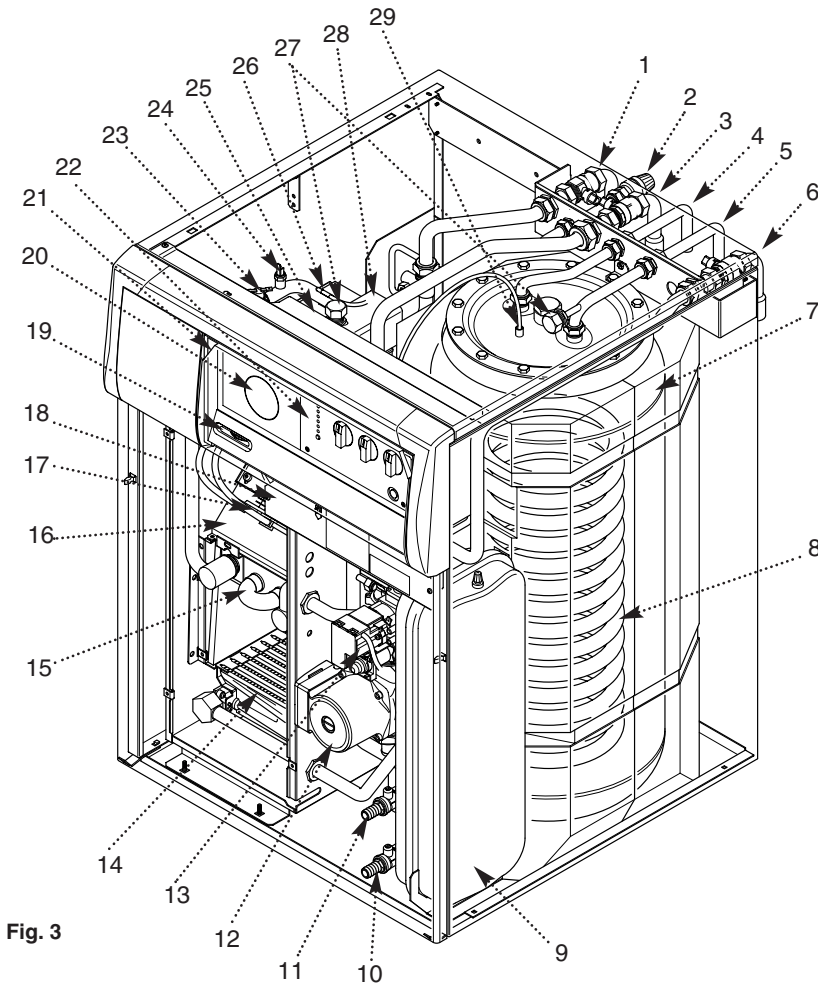
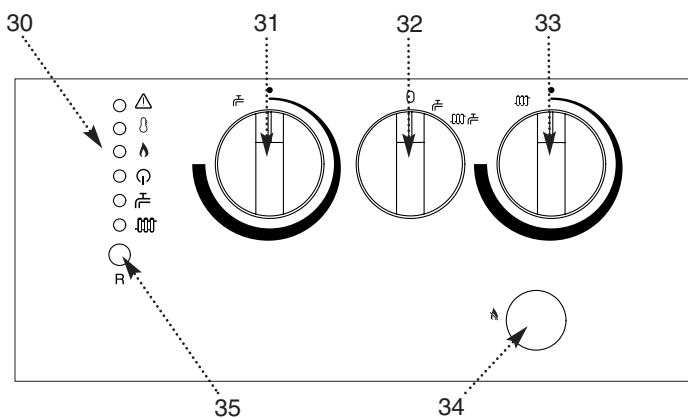
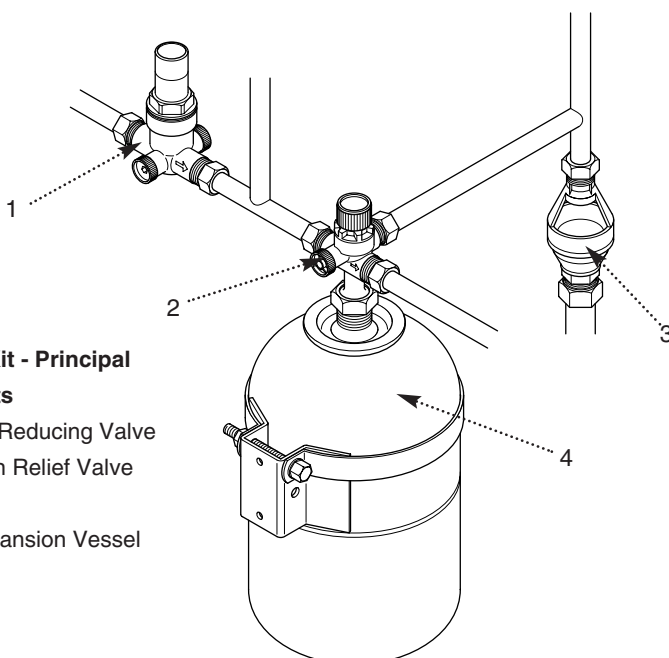

Fig. 3



Unvented Kit - Principal Components

1. Pressure Reducing Valve
2. Expansion Relief Valve
3. Tundish
4. DHW Expansion Vessel



2.2 Optional Extras

1. Various flue extensions, bends, vertical flue kits, control accessories etc. are available as optional extras. These are detailed in a separate publication.

Central Heating Circuit

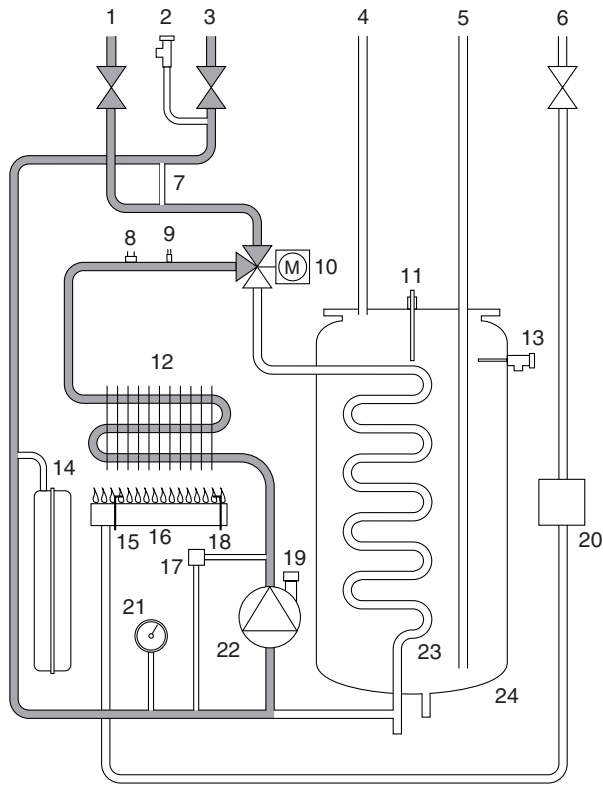

Fig. 4

Key

- | | |
|---|--------------------------------------|
| 1 Heating Flow | 13 Temperature/Pressure Relief Valve |
| 2 Central Heating Pressure Relief Valve | 14 Central Heating Expansion Vessel |
| 3 Heating Return | 15 Ignition Electrode |
| 4 Domestic Hot Water Outlet | 16 Burner |
| 5 Cold Water Inlet | 17 Differential Pressure Switch |
| 6 Gas Inlet | 18 Flame Sensing Electrode |
| 7 By-Pass | 19 Automatic Air Vent |
| 8 Safety Limit Thermostat | 20 Gas Valve |
| 9 Primary Flow Temperature Sensor | 21 Pressure Gauge |
| 10 3-Way Diverter Valve | 22 Pump |
| 11 Hot Water Storage Temperature Sensor | 23 Storage Cylinder Heating Coil |
| 12 Main Heat Exchanger | 24 Storage Cylinder |

Domestic Hot Water Circuit

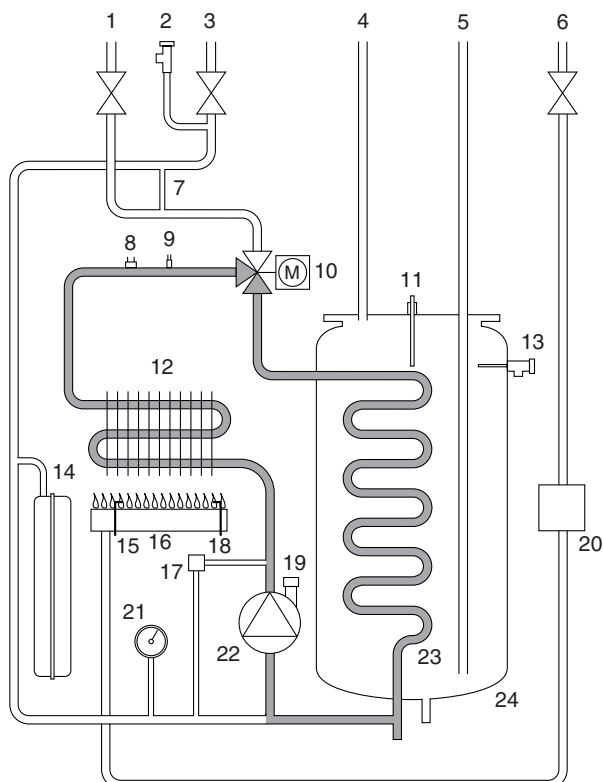



Fig. 5

3.0 Appliance Operation

3.1 Boiler Operation

1. The boiler operating mode is controlled by the selector switch on the control panel. When set to  it will operate in the Domestic Hot Water and Central Heating modes. For Domestic Hot Water only the selector switch should be set to .

2. Domestic hot water supply always takes priority over central heating. If a demand for hot water is required during a central heating period, the boiler will automatically switch to hot water mode until the demand is satisfied i.e. storage water has reached the set temperature. Interruption to the central heating only occurs when there is a demand for hot water and should not be apparent to the User.

3. Central Heating Mode (Fig. 4)

If there is a call for central heating the diverter valve operates and the pump circulates the primary heating water, operating the differential pressure switch. The fan will run at full speed; once the air pressure switch has been proved the burner will light. The burner output then automatically adjusts to suit the system demand; as the temperature of the heating water in the boiler approaches that set by the adjustable central heating control knob the burner output is reduced. When this set temperature is reached, the burner extinguishes and the fan stops. The pump continues to run for 3 minutes to prevent residual heat build up in the boiler. The burner will not relight for 3 minutes unless there is a demand for domestic hot water during this period.

4. Domestic Hot Water Mode (Fig. 5)

When there is a demand for hot water (temperature of stored hot water is below that set by the thermostat), the pump will start to circulate the primary heating water, operating the differential pressure switch. The fan will run at full speed; once the air pressure switch has been proved the burner will light. The burner output then automatically adjusts to suit the demand required to raise the temperature of the domestic hot water within the store to the temperature set by the adjustable domestic hot water control knob. When this temperature is reached the burner extinguishes and the fan stops. The pump continues to run for 3 minutes to prevent residual heat build up in the boiler. When the hot water demand has been satisfied, the 3-way diverter valve operates to divert the primary heating water to the central heating, if the selector is set to  and there is a C.H. demand.

IMPORTANT: When the selector switch is in the '0' (Off) position the electrical supply to the boiler is isolated. The boiler will not operate and the integral timer (if fitted) will require resetting once the selector switch is turned to either the DHW or CH position

3.2 Frost Protection Mode

1. The frost protection feature will operate when the selector switch is in the central heating and domestic hot water mode.

The gas and electrical supplies to the boiler must be on and the system pressure between 0.5 and 2.5 bar.

2. If the system temperature falls below 5° C, then the boiler will fire until the water temperature has been raised.

3. Further frost protection can be incorporated by using a frost thermostat to protect the whole system.

3.3 Pump Protection

1. With the selector switch in either operating position the pump will automatically operate for 1 minute in every 24 hours to prevent sticking.

4.0 Technical Data

| | | |
|--|---------------------------|-----------------|
| Appliance Type | C ₁₂ | C ₃₂ |
| Appliance Category | CAT II 2H 3+ | |
| Heat Input (gross) | Max | Min |
| C/H & DHW kW | 31.1 | 11.9 |
| Btu/h | 106,130 | 40610 |
| Heat Output | Max | Min |
| C/H & DHW kW | 28.0 | 10.4 |
| Btu/h | 95,555 | 35,492 |
| Gas Rate | Max | Min |
| (Natural Gas) | | |
| (After 10 Mins) m ³ /h | 3.29 | 1.26 |
| ft ³ /h | 116 | 44 |
| Burner Pressure (Natural Gas) | Room sealed panel fitted | |
| | Max | Min |
| mbar | 11.8 ± 0.5 | 1.8 ± 0.2 |
| in wg | 4.7 ± 0.2 | 0.72 ± 0.2 |
| Inlet Pressure (Natural Gas) | | |
| mbar | 20 | |
| in wg | 8 | |
| Burner Injector (Natural Gas) | 18 x 1.18mm Diameter | |
| NO_x Class | 3 | |
| Electrical Supply | 230V~ 50Hz | |
| Power Consumption | 190W | |
| External Fuse Rating | 3A | |
| Internal Fuse Rating | F2A | |
| External Controls | 230V switching | |
| Electrical Protection | IPx4D | |
| (Appliance must be connected to an earthed supply) | | |
| Flue Terminal Dimensions | Diameter | 100mm |
| | Projection | 93mm |
| Connections | copper tails | |
| Gas Supply | - 22mm | |
| Central Heating Flow | - 22mm | |
| Central Heating Return | - 22mm | |
| Cold Water Mains Inlet | - 15mm | |
| DHW Flow | - 15mm | |
| Pressure Relief Discharge | - 15mm | |
| Outercase Dimensions | | |
| Casing Height | - 850mm | |
| Casing Width | - 600mm | |
| Casing Depth | - 630mm | |
| Clearances | | |
| LH Side | 5mm Min | |
| RH Side | 5mm Min | |
| Above Casing | 500mm Min | |
| Front | 500mm Min (For Servicing) | |
| Front | 5mm Min (In Operation) | |
| Weights | kg | |
| Packaged Weight (gross) | 95 | |
| Installation Lift Weight | 83 | |
| Total Operational Weight | 140 | |

Central Heating Primary Circuit

Pressures

| | |
|----------------------------|-----|
| CH Expansion Vessel | bar |
| Nominal Pre-charge | 0.8 |
| Safety Discharge | 3 |
| Max Operating | 2.5 |
| Min Operating | 0.5 |
| Recommend Operating | 1-2 |

Max Capacity of CH System 125 litres

Primary Water Content of Boiler 3.2 litres

Pump

Available Head See graph below

Built In Bypass

| | |
|---|-----|
| | l/h |
| Min Circulation Rate (CH Primary Circuit) | 215 |
| e.g. TRVs all closed | |

Water Temperature

C.H. Flow Temp (adjustable)
30° C to 82° C max (± 5° C)

SEDBUK Declaration For Maxflow Combi FS

The seasonal efficiency (SEDBUK) is 78.6 %

This value is used in the UK Government's Standard Assessment Procedure (SAP) for energy rating of dwellings. The test data from which it has been calculated have been certified by 0051.

DHW Circuit

Time To Raise Water Storage 50° C

9 minutes

Reheat Time 70% of storage
8 minutes

| | |
|------------------|-----|
| Pressures | bar |
| Max Operating | 3.5 |
| Min Operating | 0.1 |

Min Operating Pressure at 12 l/min 1.6

| | | |
|--------------------------------|-----------|---------|
| Flow Rates | l/min | l/30min |
| DHW Flow Rate | | |
| Continuous @ 30° C Rise | 14 | |
| DHW Flow Rate | | |
| Continuous @ 35° C Rise | 11.4 | |
| Storage Flow Rate @ 30° C Rise | | 450 |
| Min Working | | |
| DHW Flow Rate | 1 | |
| Max. Flow Rate | 18 l/min. | |

Invented DHW Expansion Vessel

See Sections 6.8 & 8.6 for information

DHW Store Temp./Pressure Relief Valve

| | |
|---------------------|-------|
| Maximum Pressure | 7 bar |
| Maximum Temperature | 90° C |

DHW Inlet Pressure Relief Valve

| | |
|------------------|-------|
| Maximum Pressure | 6 bar |
|------------------|-------|

Water Temperature

D.H.W. Flow Temp (adjustable)
5° C to 65° C max (± 5° C)

Water Storage Volume 54 litres

LPG Gases / Propane and Butane

Burner Injector 18 x 0.69mm diameter

| Burner Pressure | Max Rate | Min Rate |
|-----------------|------------|----------|
| Propane | mbar 35.5 | 7.6 |
| | in wg 14.2 | 3.0 |
| Butane | mbar 28.2 | 4.0 |
| | in wg 11.3 | 1.6 |

| Inlet Pressures | Butane | Propane |
|-----------------|--------|---------|
| mbar | 28 | 37 |
| in wg | 11.2 | 14.8 |

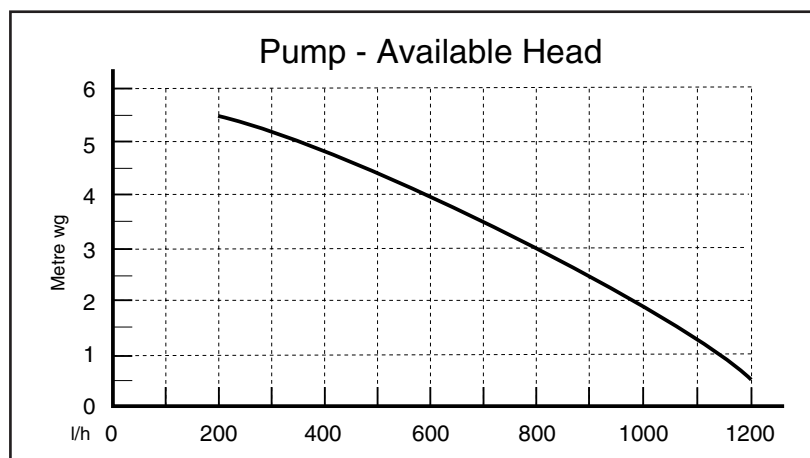

5.0 Dimensions and Fixings

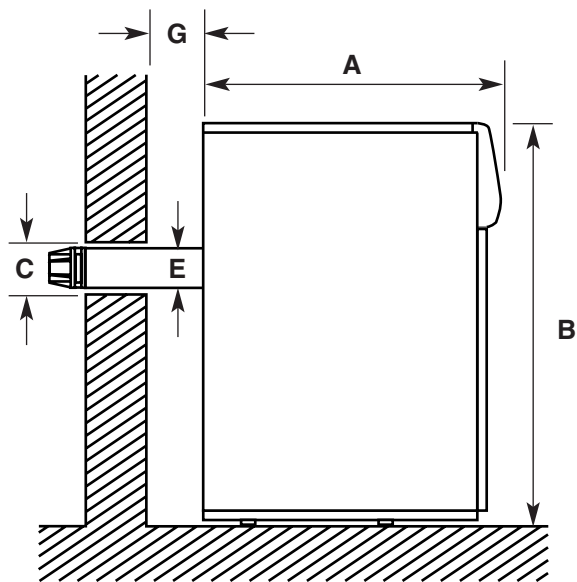

| DIMENSIONS | |
|------------|--------------|
| A | 630mm |
| B | 850mm |
| C | 107mm Ø Min. |
| D | 600mm |
| E | 100mm Ø Min. |
| F | 93mm |
| G | 120mm |

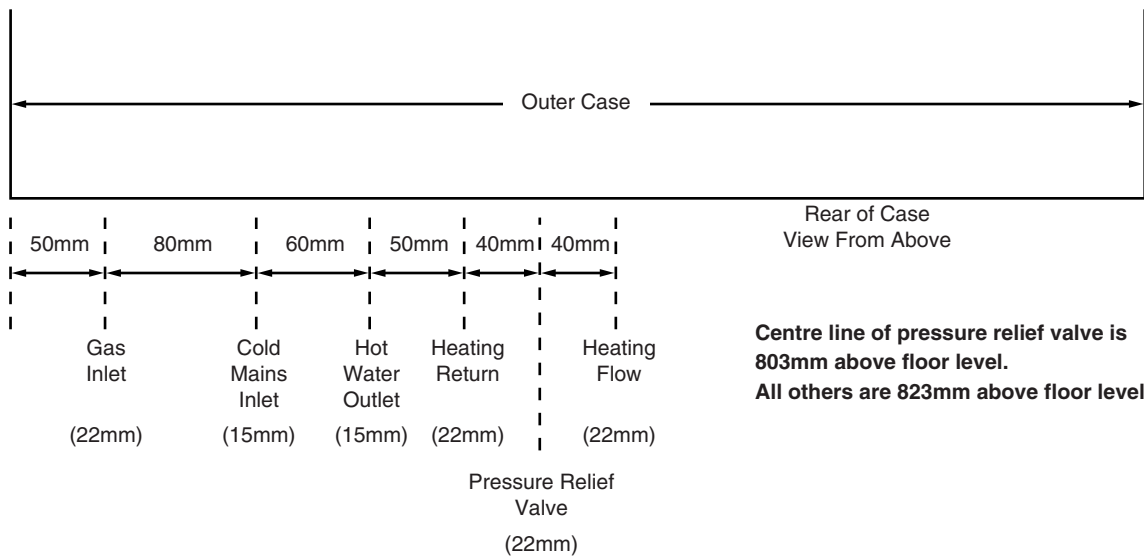
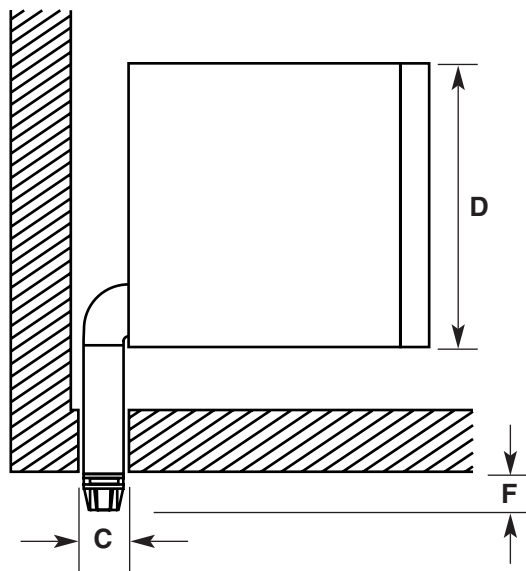

6.0 System Details

6.1 Information

1. The Baxi Maxflow Combi FS Combination Boiler is a 'Water Byelaws Scheme - Approved Product'. To comply with the Water Byelaws your attention is drawn to the following installation requirements and notes (IRN).

- a) IRN 001 - See text of entry for installation requirements and notes.
- b) IRN 302 - Byelaw 14.

2. Reference to the WRc publications, 'Water fittings and materials directory' and 'Water supply byelaws guide' give full details of byelaws and the IRNs.

6.2 Central Heating Circuit

1. The appliance is suitable for fully pumped SEALED SYSTEMS ONLY.

Treatment of Water Circulating Systems

- All recirculatory water systems will be subject to corrosion unless an appropriate water treatment is applied. This means that the efficiency of the system will deteriorate as corrosion sludge accumulates within the system, risking damage to pump and valves, boiler noise and circulation problems.
- For optimum performance after installation this boiler and its associated central heating system must be flushed in accordance with the guidelines given in BS 7593 "Treatment of water in domestic hot water central heating systems".
- This must involve the use of a proprietary cleanser, such as BetzDearborn Sentinel X300 or X400, or Fernox Superfloc. Full instructions are supplied with the products, but for immediate information please contact BetzDearborn (0151 420 9563) or Fernox (01799 550 811) directly.
- For long term protection against corrosion and scale, after flushing it is recommended that an inhibitor such as BetzDearborn Sentinel X100, or Fernox MB-1 or Copal is dosed in accordance with the guidelines given in BS 7593.

Failure to flush and add inhibitor to the system may invalidate the appliance warranty.

- It is important to check the inhibitor concentration after installation, system modification and at every service in accordance with the manufacturer's instructions. (Test kits are available from inhibitor stockists.)
 - For information or advice regarding any of the above contact the Baxi Helpline.
-

6.0 System Details

6.3 Bypass

1. The boiler has an integral bypass and in most cases this should suffice. However in certain circumstances, e.g. on systems where there is a high resistance and TRV's are fitted to all the radiators it may be necessary to fit an external by-pass. For example, a 15mm pipe between the flow and return controlled by a valve, or an uncontrolled radiator.

6.4 System Control

1. The boiler is designed for use in a heating system that incorporates external controls, i.e. a minimum of a timer device.

2. Suitable timer kits are available as optional extras.

3. For optimum operating conditions and maximum economy the fitting of a programmable thermostat, such as the Baxi Combi Controller, is recommended.

6.0 System Details

6.5 System Filling and Pressurising

1. A filling point connection on the central heating return pipework must be provided to facilitate initial filling and pressurising and also any subsequent water loss replacement/refilling.
2. There are connection points on the mains cold water inlet and central heating return isolating taps to which the optional filling loop kit (Part No. 248221) can be assembled.
3. The filling method adopted must be in accordance with the Water Supply (Water Fittings) regulations and the Water Bylaws (Scotland).
4. Your attention is drawn to: Paragraph 24 of Schedule 2 Section 8 of the publication Water Regulations Guide which gives recommendations and guidance on approved methods for filling sealed systems.

5. The sealed primary circuits may be filled or replenished by means of a temporary connection between the primary circuit and a supply pipe provided the arrangement is in accordance with Diagram R24.2a of the Water Regulations Guide.

6. The temporary hose must be completely removed at both ends after use.

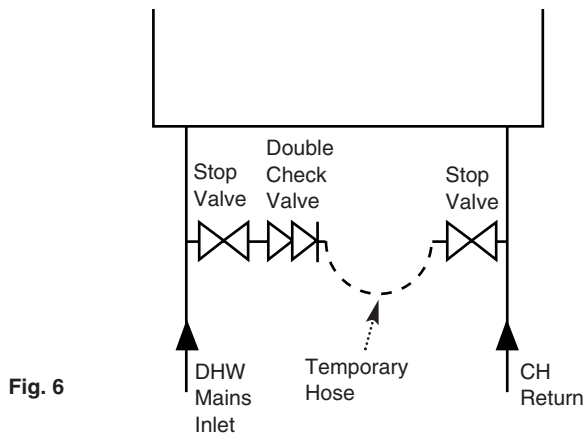
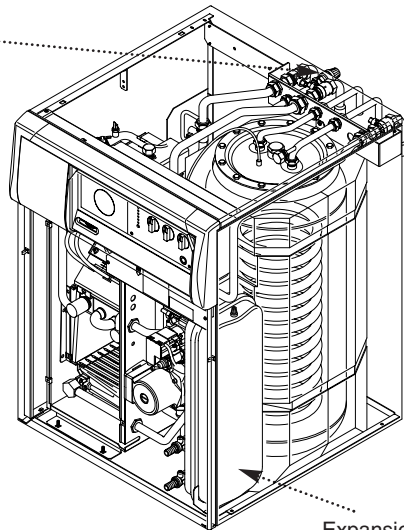

Fig. 6



Expansion Vessel

Fig. 7

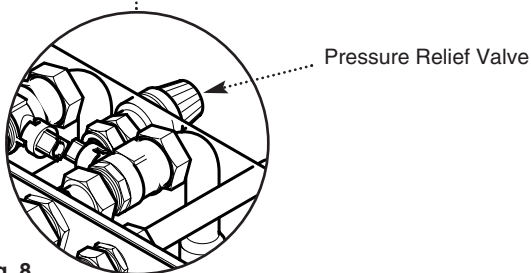

Fig. 8

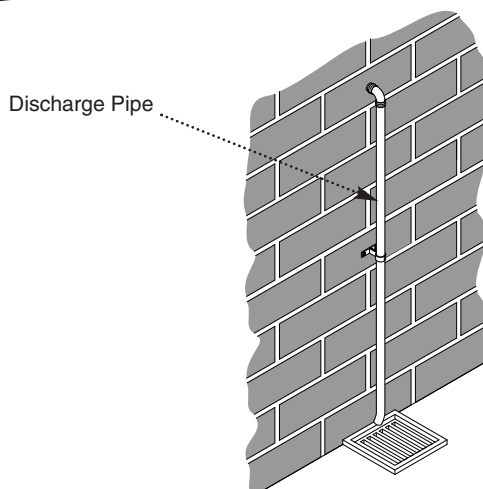

Fig. 9

6.6 Expansion Vessel (Fig. 7) (Central Heating only)

1. The appliance expansion vessel is pre-charged to 0.8 bar. Therefore, the cold fill pressure is 0.8 bar. The vessel is suitable for correct operation for system capacities up to 125 litres (27.5gal). For greater system capacities an additional expansion vessel must be fitted - refer to BS 7074 Pt 1.

6.7 Pressure Relief Valve (Fig. 8)

1. The pressure relief valve is set at 3 bar, therefore all pipework, fittings, etc. should be suitable for pressures in excess of 3 bar.
2. The pressure relief discharge pipe should be not less than 15mm dia, run continuously downward, and discharge outside the building, preferably over a drain. It should be routed in such a manner that no hazard occurs to occupants or causes damage to wiring or electrical components. The end of the pipe should terminate facing down and towards the wall (Fig. 9).
3. The discharge must not be above a window, entrance or other public access. Consideration must be given to the possibility that boiling water/steam could discharge from the pipe.

6.0 System Details

6.8 Domestic Hot Water Circuit

1. All DHW circuits, connections, fittings, etc. should be fully in accordance with relevant standards, the Water Supply (Water Fittings) Regulations and the Water Bylaws (Scotland).
 2. Your attention is drawn to:
Schedule 2, Section 6 of the publication Water Regulations Guide which relates to backflow prevention.
 3. The boiler's maximum working mains pressure is 8 bar, therefore all pipework, connections, fittings, etc. should be suitable for pressures in excess of 8 bar. The pressure reducing valve supplied in the 'Unvented Kit' must be fitted. The manufacturer of any outlet fittings, such as a shower valve, may require a lower maximum pressure. The pressure reduction must take account of all fittings connected to the DHW system.
-

6.9 Showers

1. If a shower control is supplied from the appliance it should be of the thermostatic or pressure balanced type. Thermostatic type shower valves provide the best comfort and guard against water at too high a temperature. Existing controls may not be suitable - refer to the shower valve manufacturer.
-

6.10 Hard Water Areas

1. If the area of the installation is recognised as a HARD WATER AREA then a suitable device should be fitted to treat the mains water supply to the boiler.
-

7.0 Site Requirements

7.1 Information

1. The installation must be carried out by a CORGI Registered Installer or other registered competent person and be in accordance with the relevant requirements of the current Gas Safety (Installation and Use) Regulations, the Building Regulations (Scotland)(Consolidation), the Local Building Regulations, the current I.E.E. Wiring Regulations and the bye laws of the Local Water Undertaking. Where no specific instruction is given reference should be made to the relevant British Standard Codes of Practice. For Ireland install in accordance with IS 813 "Installation of Gas Appliances".

7.2 B.S. Codes of Practice

| STANDARD | SCOPE |
|-----------------|---|
| B.S. 6891 | Gas Installation. |
| B.S. 5440: Pt 1 | Flues. |
| B.S. 5440: Pt 2 | Air Supply. |
| B.S. 5546 | Installation of hot water supplies for domestic purposes. |
| B.S. 7074 | Expansion vessels and ancillary equipment for sealed water systems. |
| B.S. 5449: Pt 1 | Forced circulation hot water systems. |
| B.S. 6798 | Installation of gas fired hot water boilers. |

WARNING - The addition of anything that may interfere with the normal operation of the appliance without the express written permission of Baxi UK Limited could invalidate the appliance warranty and infringe the Gas Safety (Installation and Use) Regulations.

7.3 Clearances (Fig. 11 & 12)

1. The boiler should be positioned 120mm from the wall to allow for access to pipework and fitting of the isolating valves.

2. Sufficient clearance must be left at one side to accommodate the components of the unvented kit. The clearance should be at least 300mm to fit the D.H.W. expansion vessel, tundish and attendant pipework.

IMPORTANT: When installing a left hand flue system it is not practical to site the components of the unvented kit to the left of the boiler.

3. The floor must be flat and level extending for 720mm out from the wall and 600mm wide.

4. The minimum clear spaces needed around the boiler measured from the casing are as follows:

| | |
|-----------------|-------------------------|
| Top | - 10mm (In operation) |
| | - 500mm (For servicing) |
| Left hand side | - 5mm |
| Right hand side | - 5mm |
| Front | - 500mm (For Servicing) |
| | 35mm (In operation) |
| Rear | - 120mm |

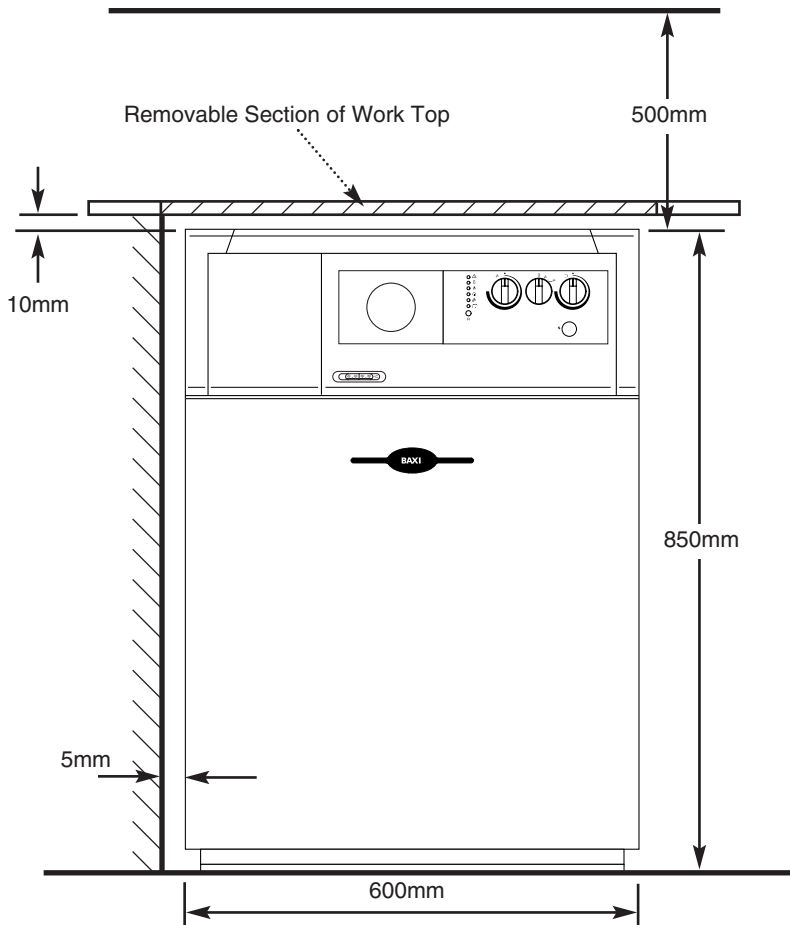

Fig. 11

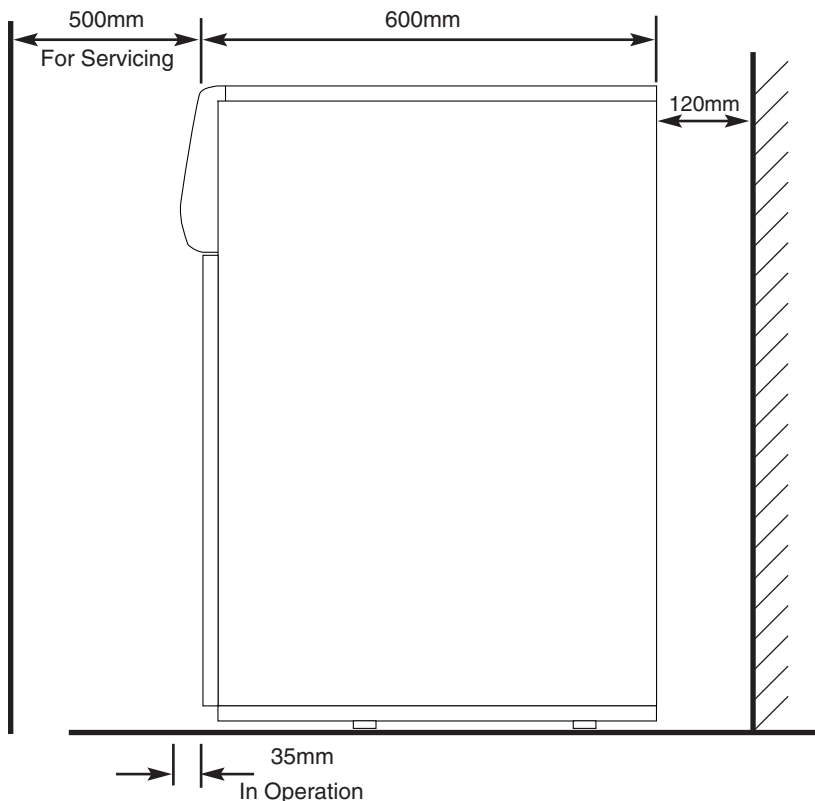

Fig. 12

7.0 Site Requirements

7.4 Location

1. The boiler must be positioned on a flat and level floor or base which must be capable of supporting the full operational weight of the boiler. The flue must pass through an outside wall or roof and discharge to atmosphere in a position permitting satisfactory removal of combustion products and providing an adequate air supply.

2. The boiler should be fitted within the building unless otherwise protected by a suitable enclosure i.e. garage or outhouse. (The boiler may be fitted inside a cupboard - see Section 7.5).

3. If the boiler is sited in an unheated enclosure then it is recommended to leave the ON/OFF Selector Switch in the domestic hot water and central heating position to give frost protection.

4. If the boiler is fitted in a room containing a bath or shower reference must be made to the current I.E.E. Wiring Regulations and Building Regulations. If the boiler is to be fitted into a building of timber frame construction then reference must be made to the current edition of Institute of Gas Engineers Publication IGE/UP/7 (Gas Installations in Timber Framed Housing).

| Free area of air vent (cm ²) | | |
|--|---------------|------------------|
| Position of vent | Air from room | Air from outside |
| High Level | 310.5 | 155.25 |
| Low Level | 310.5 | 155.25 |

Table 1

7.5 Ventilation of Compartments

1. The boiler does not require any air vents in the room in which it is installed. If it is installed in a cupboard or compartment permanent air vents are required at high and low levels (see Table 1). The vents must communicate with the same room or be direct to outside on the same wall.

2. When installed in a cupboard or compartment the minimum clearances must be maintained.

7.6 Gas Supply

1. The gas installation should be in accordance with BS6891.

2. The connection to the appliance is a 22mm copper tail. This is connected to the gas service cock (Fig. 14).

3. Ensure that the pipework from the meter to the appliance is of adequate size. Do not use pipes of a smaller diameter than the boiler gas connection (22mm).

7.7 Electrical Supply

1. External wiring must be correctly earthed, polarised and in accordance with current I.E.E. Wiring Regulations.

2. The mains supply is 230V ~ 50Hz fused at 3A.

NOTE: The method of connection to the electricity supply must facilitate complete electrical isolation of the appliance.

Connection may be via a fused double-pole isolator with a contact separation of at least 3mm in all poles and servicing the boiler and system controls only.

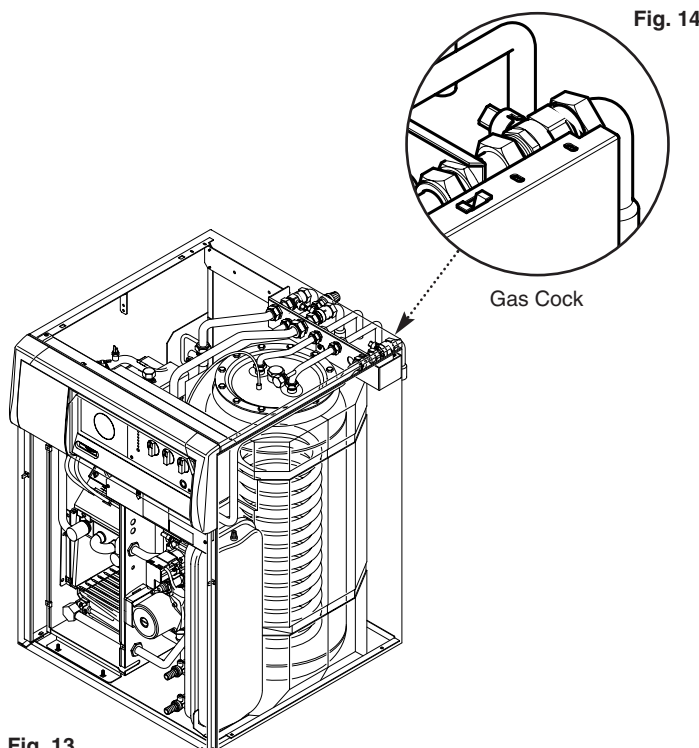

Fig. 13

Fig. 14

Gas Cock

7.0 Site Requirements

7.8 Flue

1. The flue terminal position must always be in accordance with the current edition of B.S. 5440 Part 1, and either Part J of the Building Regulations England and Wales or Part J of the Building Standards (Scotland) Regulations as appropriate.

2. If the terminal discharges onto a pathway or passageway, check that combustion products will not cause a nuisance and that the terminal will not obstruct the passageway.

3. If a terminal is less than 2 metres above a balcony, above ground or above a flat roof to which people have access, then a suitable terminal guard must be provided.

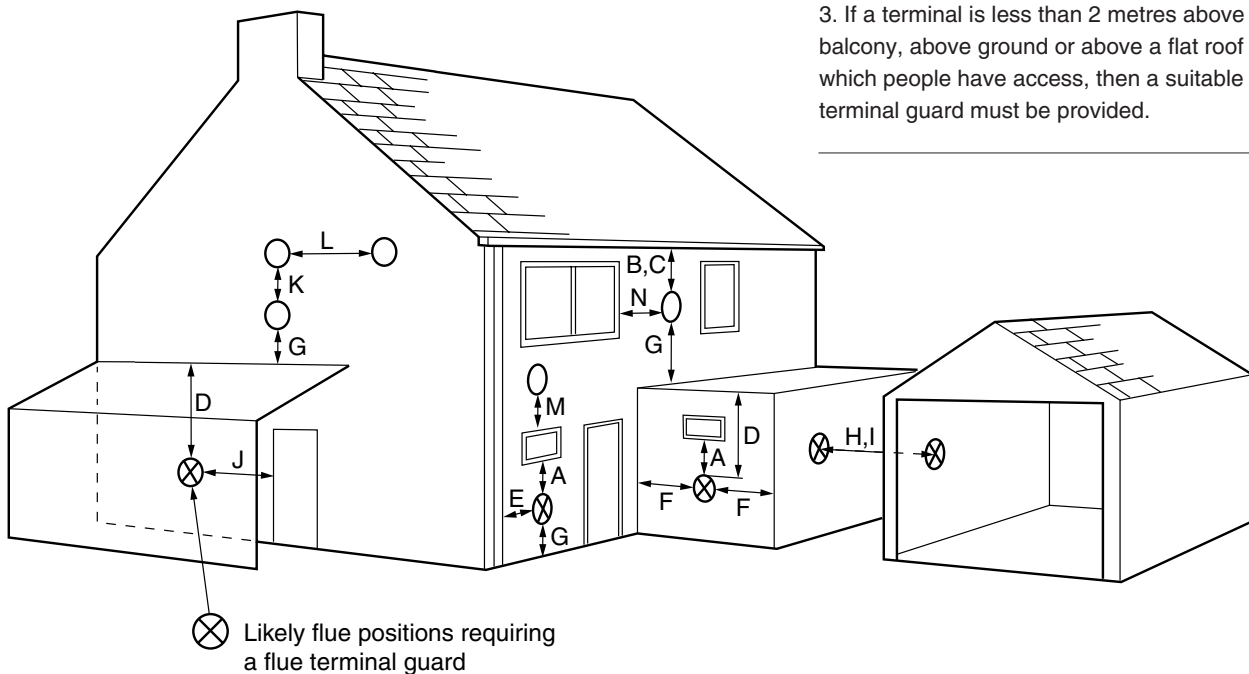
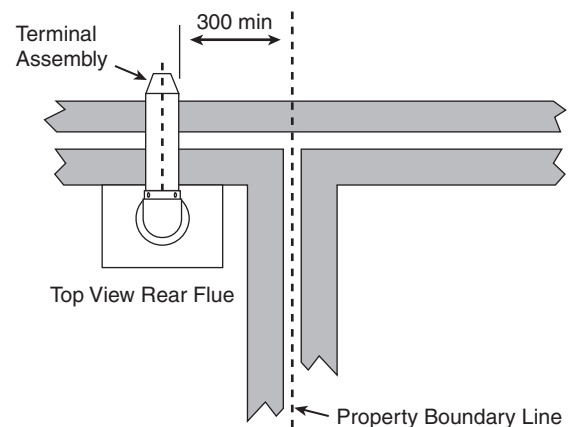

Fig. 10

Terminal Position with Minimum Distance (Fig. 10) (mm)

| | | |
|---|---|------|
| A | Directly below an openable window, air vent or any other ventilation opening. | 300 |
| B | Below gutters, drain or soil pipes. | 25 |
| C | Below eaves. | 25 |
| D | Below balconies or car port roof. | 25 |
| E | From vertical drain pipes and soil pipes. | 25 |
| F | From internal or external corners. | 25 |
| G | Above ground or balcony level. | 300 |
| H | From a surface facing a terminal. | 600 |
| I | Facing a terminal. | 1200 |
| J | For an opening (door/window) in car port into dwelling. | 1200 |
| K | Vertically from a terminal on the same wall. | 1500 |
| L | Horizontally from a terminal on the same wall. | 300 |
| M | Above an opening, air brick opening window etc. | 300 |
| N | Horizontally to an opening, air brick opening window etc. | 300 |



7.0 Site Requirements

7.9 Flue Dimensions

When routed to the rear the flue must be at least 295mm long, plus the thickness of the wall. The maximum length when using the standard flue kit is 1m from adaptor to terminal .

The maximum permissible equivalent flue length is: 5 metres.

NOTE: Each additional 45° of flue bend will account for an equivalent flue length of 0.5m.
eg. 45° = 0.5m, 90° = 2 x 45° = 1m etc.

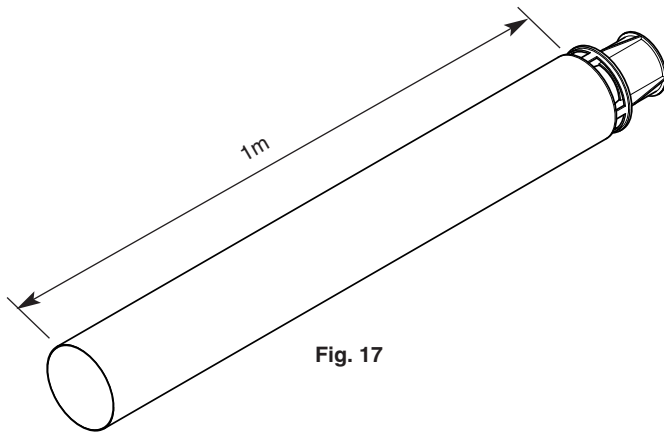

Fig. 17

7.10 Flue Terminal Trim

1. Once the flue is secure the trim can be fitted if required.

2. Remove the protective backing from the adhesive seal. Apply the seal to the rear of the trim flange (Fig. 18).

3. Locate the trim over the flue terminal and push it back to the wall to compress the seal (Fig. 19).

Fig. 18

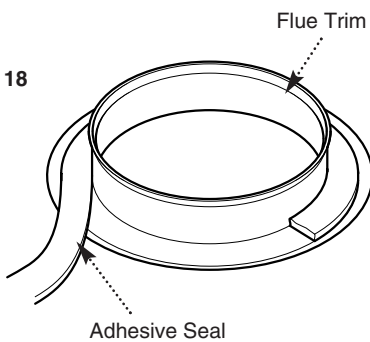
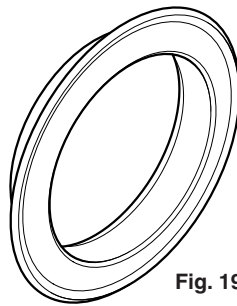

Fig. 19



7.11 Terminal Guard (Fig. 20)

1. When codes of practice dictate the use of terminal guards, they can be obtained from most Plumbers' and Builders' Merchants.

2. There must be a clearance of at least 50mm between any part of the terminal and the guard.

3. When ordering a terminal guard, quote the appliance model number.

4. The flue terminal guard should be positioned centrally over the terminal and fixed as illustrated.

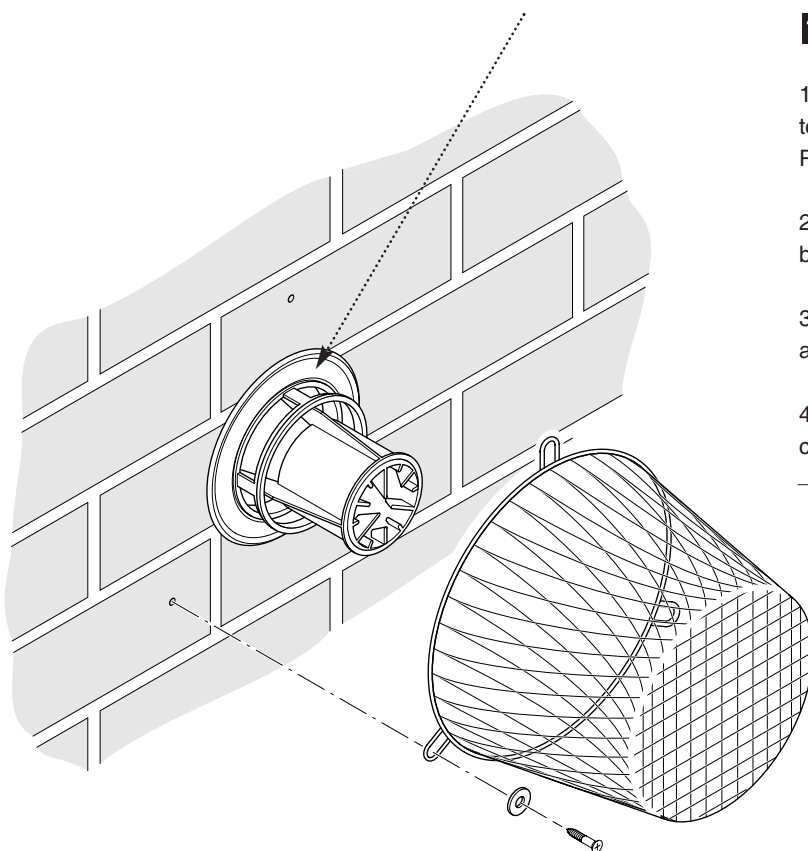

Fig. 20

7.0 Site Requirements

7.12 Flue Options

1. The Baxi Maxflow Combi FS can be fitted with flue systems as illustrated.

2. The standard flue is suitable only for horizontal applications.

3. Maximum permissible equivalent flue lengths are:-

| | |
|----------------------|-------------|
| Horizontal | 5.0 metres |
| Vertical | 3.0 metres |
| Vertical (Twin Pipe) | 10.0 metres |

4. Any "in line" bends in the flue system must be taken into consideration, including where a 90° bend is connected directly to the boiler when the flue is taken vertically or to the left.

Their equivalent lengths are:-

Concentric Pipes:

| | |
|----------|------------|
| 45° bend | 0.5 metres |
| 90° bend | 1.0 metres |

Twin Flue Pipe

| | |
|----------|-------------|
| 45° bend | 0.25 metres |
| 90° bend | 0.50 metres |

Bends can be used to route the flue pipe around obstacles within the dwelling and to enable the flue terminal to be positioned according to requirements. By combining two 45° bends and a straight piece, a wide 90° bend can be achieved. As it is possible to rotate the bends through 360°, various "S" bends can be produced.

5. The illustrations opposite show examples of maximum equivalent lengths.

6. Full details of part numbers and descriptions of all optional flue components and kits can be found in the Baxi Gas Central Heating Boilers Installers' Guide.

7. Instructions for guidance and fitting are included in each kit where appropriate.

7.13 Extensions & Additional Elbows

1. The method of connecting any flue extensions or additional elbows is the same as that for connecting the standard flue and 90° elbow as described in Section 8.3.

2. If, for example, when a flue extension is connected to a 90° elbow the flue duct will project from the air duct at the unconnected end by the same amount as the flue duct spigot does from the elbow. Further elbows or extensions can then be added to this.

3. Similarly, a concentric flue can be connected to the boiler adaptor in the same manner as it does to the elbow to provide a vertical flue.

4. The additional 90° elbow available is identical to the elbow supplied with the standard flue. 45° elbows are of the same principle.

5. Extensions can be cut according to the requirements of the installation.

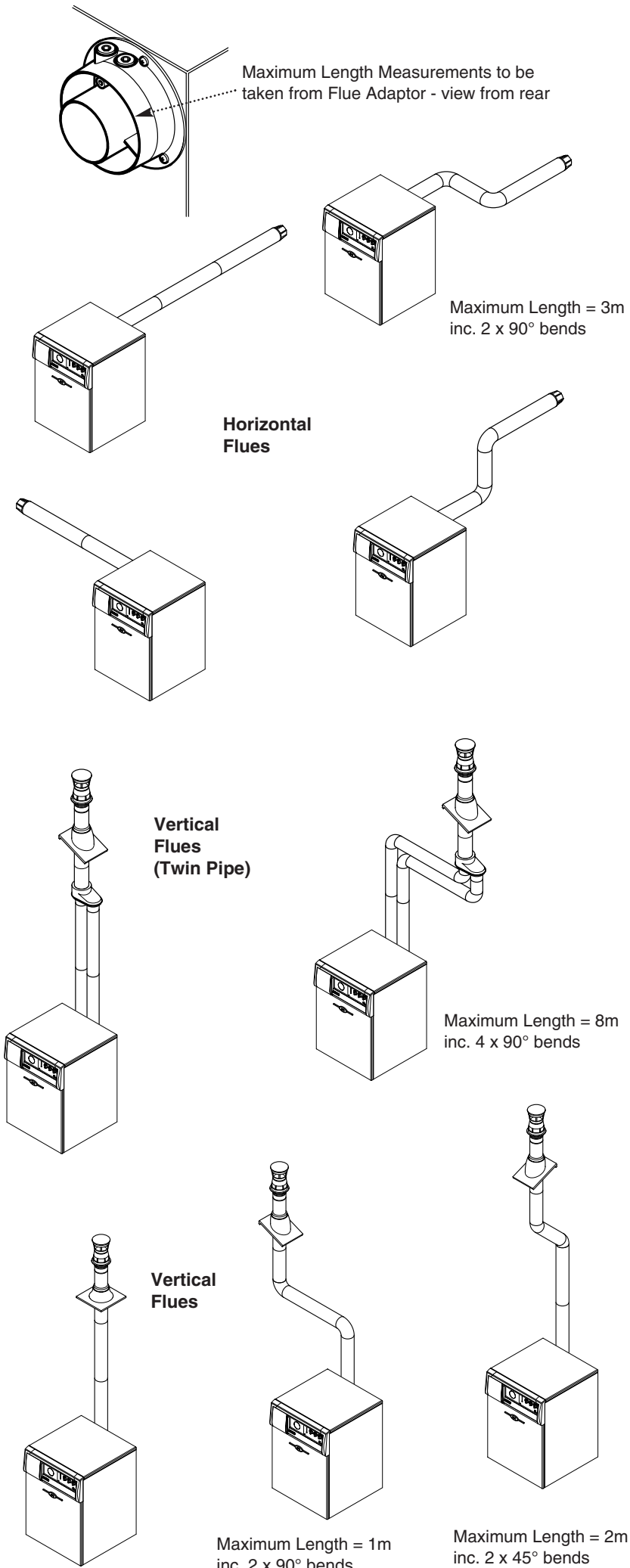

8.0 Installation

8.1 Initial Preparation

The gas supply, gas type and pressure must be checked for suitability before connection (see Section 7.6).

1. Mark the centre of the flue hole as shown (Figs. 21 & 22). If required, mark the position of the gas and water pipes (see Section 5.0).
2. Cut the hole for the flue (minimum diameter 107mm).
3. Ensure that the floor or base on to which the boiler is to be fitted is clean and free from debris.
4. Install all pipework that will be behind the boiler, including the pressure relief discharge pipe (see section 6.7) and components and pipework of the domestic hot water Unvented Kit.

8.2 Flushing

1. Connect a tube to the central heating flow or return pipe.
2. Flush thoroughly (see Section 6.2 of System Details).
3. The Baxi Combi filling loop kit can be used to flush the system.

IMPORTANT: Do not use any safety valves to flush or drain the system.

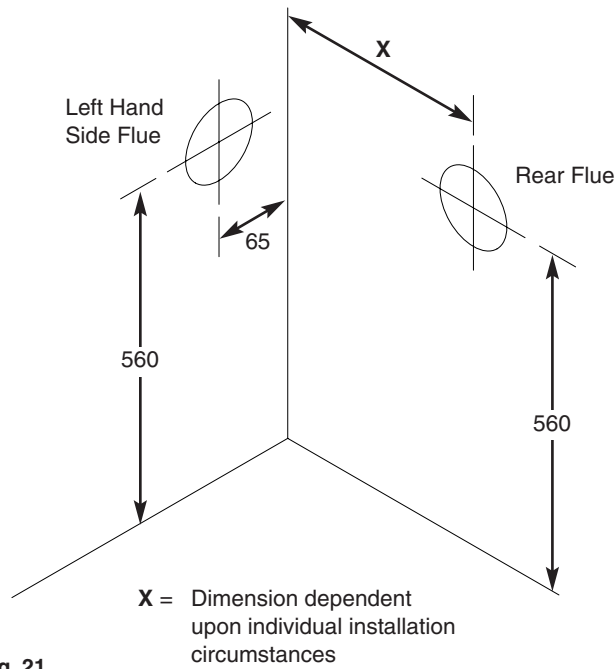

Fig. 21

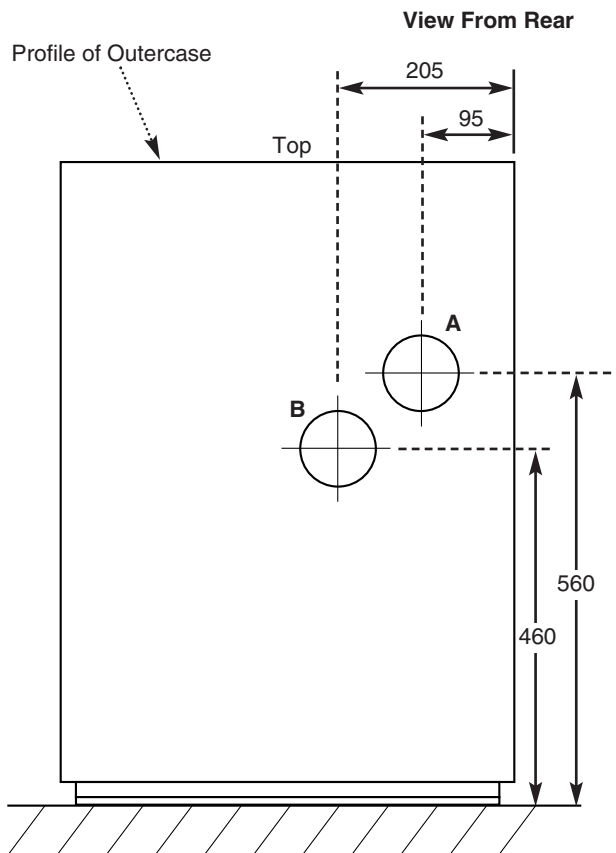

Fig. 22

A = Concentric Adaptor/
Twin Flue Duct

B = Twin Flue
Air Duct

IMPORTANT : Fitting the Flue

- The complete flue system must be fitted to the appliance before positioning when the wall against which the boiler is being installed is that through which the flue will terminate.
- When routing either to the left or vertically, sufficient length of flue must be fitted to the boiler to ensure that it extends outside the outcase. This will enable connection of the remainder of the flue system once the boiler is in position.
- A rear flue that will pass through one or more walls before the outside wall should be long enough to protrude through the first wall when the boiler is in position. This will enable connection of the remainder of the flue system.

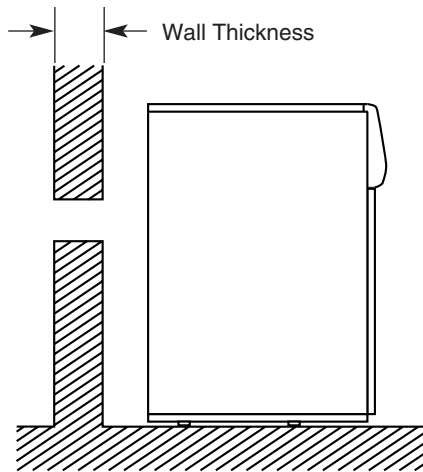

Fig. 23

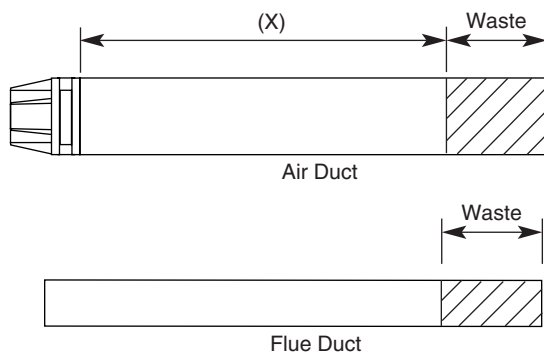

Fig. 24

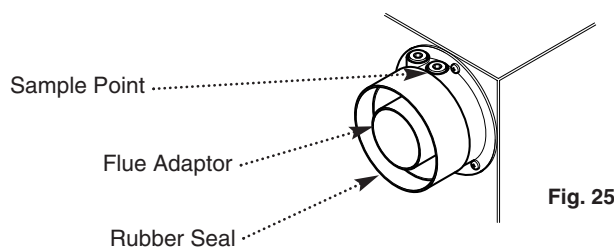

Fig. 25

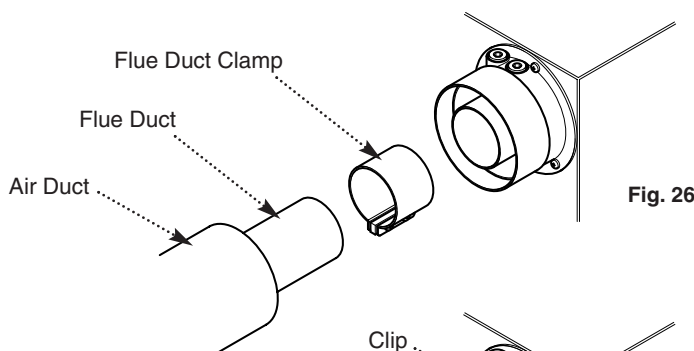

Fig. 26

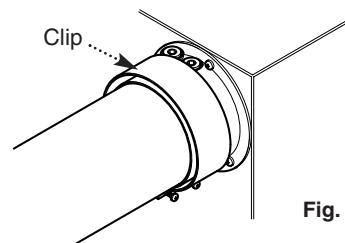

Fig. 27

8.0 Installation

8.3 Rear Flue

To route the flue to the rear it is necessary to use the horizontal flue kit (Part No. 247719). This kit includes a 90° bend, clips and seals, clamp, and a flue trim. Any other extensions or bends can also be purchased as required.

When the flue is routed directly out to the rear the bend and one clip and seal are not required.

1. Measure the wall thickness (Fig. 23). To this dimension add 295mm.
2. The sum of this shall be known as dimension "X".
3. Mark dimension "X" on the air duct, measuring from the joint of the duct and terminal. The remainder is waste material (Fig. 24).
4. Measure the length of waste and transfer the dimension to the flue duct (Fig. 24).
5. Remove the waste from both ducts. Ensure that the cut ends are square and free from burrs.
6. Take the rubber seal and position it on the boiler adaptor. Using the flue duct clamp secure the flue duct to the adaptor (Fig. 25).
7. Slide the clip over the cut end of the air duct. Engage the air duct over the flue duct, ensuring that the flue duct fully engages in the flue terminal (Fig. 26).
8. Position the rubber seal equally over the joint between the air duct and adaptor. Align the clip with the seal and tighten the screws (Fig. 27).
9. Manoeuvre the boiler backwards into position, keeping as straight as possible to avoid damaging the flue as it passes through the wall. Connect the system pipe work as described in Section 8.5

8.4 Left Side and Vertical Flue

To route the flue to either the left hand side or vertically it is necessary to use a 0.25m flue extension kit (Part No. 248189). A horizontal flue kit (Part No. 247719) or 90° flue elbow kit (Part No. 247725) and vertical flue terminal kit (Part No. 246140) will also be required. Any other extensions or bends can also be purchased as required.

1. Mark a dimension of 130mm on both the flue and air duct of the 0.25m extension and cut. Discard the remainder. Ensure that the cut ends are square and free from burrs.
2. Take the rubber seal and position it on the boiler adaptor (Fig. 28). Using the flue duct clamp secure the flue duct to the adaptor (Fig. 29). (cont.)

8.0 Installation

8.4 Left Side and Vertical Flue (cont)

3. Slide the clip over one end of the air duct. Engage the air duct over the flue duct.

4. Position the rubber seal equally over the joint between the air duct and adaptor. Align the clip with the seal and tighten the screws.

5. To fit the elbow take the rubber seal and position it on the air duct. Pass the clip over the air duct.

6. Engage the flue elbow on the air and flue ducts and pull the seal to equally cover the joint.

7. Set the elbow to the required orientation. Align the clip over the seal and tighten the screws (Fig. 30).

8. Manoeuvre the boiler backwards into position, and proceed to fit any extensions or bends as required and the appropriate terminal.

8.5 Connecting the Pipework (Fig. 31)

1. Connect the three brass extension pieces to the CH flow, CH return and gas inlet adaptors on the tap rail. Connect the fixed nuts to the adaptors.

2. Connect two of the isolating cocks to the CH flow and CH return extension pieces. Ensure that the flow arrow on each tap is correctly oriented and visible.

3. Loosely fit two of the 22mm copper elbows to the CH flow and CH return taps and connect them to the system pipework. Complete the soldered joints.

4. Loosely fit the 15mm copper elbows to the DHW flow and cold water inlet adaptors and connect them to the system pipework. Complete the soldered joints.

5. Connect the remaining isolating cock to the gas supply extension piece and loosely fit the remaining 22mm copper elbow to the gas supply pipe. Complete the soldered joint.

6. Connect the copper extension piece to the pressure relief adaptor on the tap rail. Ensure that a 15mm fibre washer is between the joint.

7. Take the length of 15mm copper discharge pipe from the kit and connect it to the pressure relief valve. Fit the valve to the copper extension and discharge pipe using fibre washers.

8. Disconnect all pipes and insert the correct washer between the joints - fibre for water and rubber for gas.

9. Tighten all pipe joints and ensure that the square tap on each isolating cock will not prevent correct fitting of the case top panel.

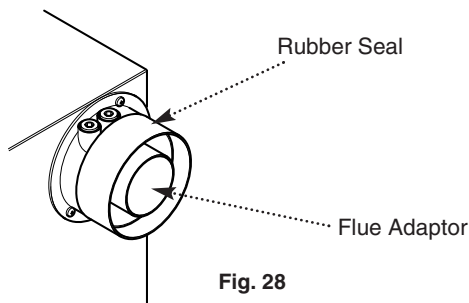

Fig. 28

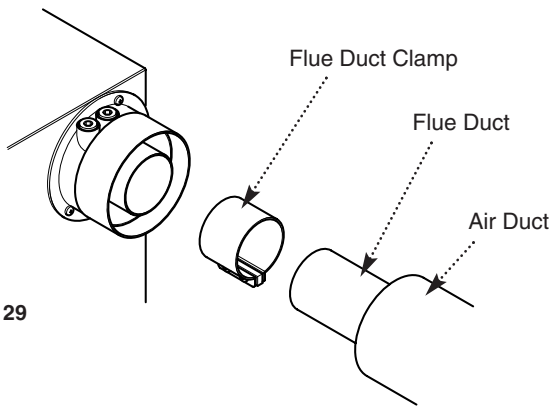

Fig. 29

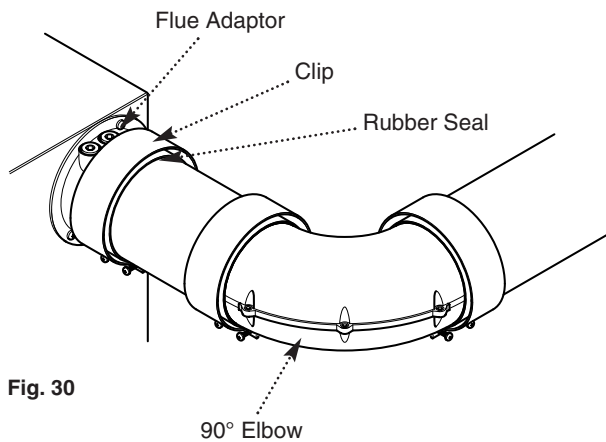

Fig. 30

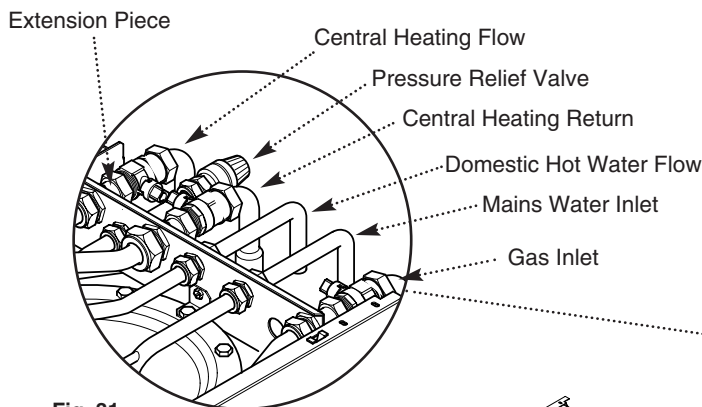
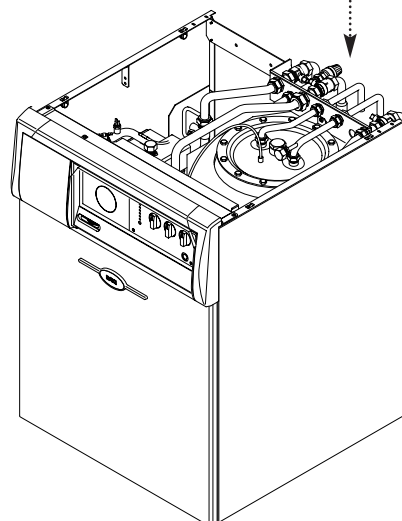

Fig. 31



8.0 Installation

8.6 Unvented Hot Water Storage (Fig. 32)

IMPORTANT: When installing a left hand flue system it is not practical to site the components of the unvented kit to the left of the boiler.

NOTE: The installation is subject to Building Regulations approval and the Local Authority must be informed of the intent to install. Consideration must be given to Building Regulations document G3.

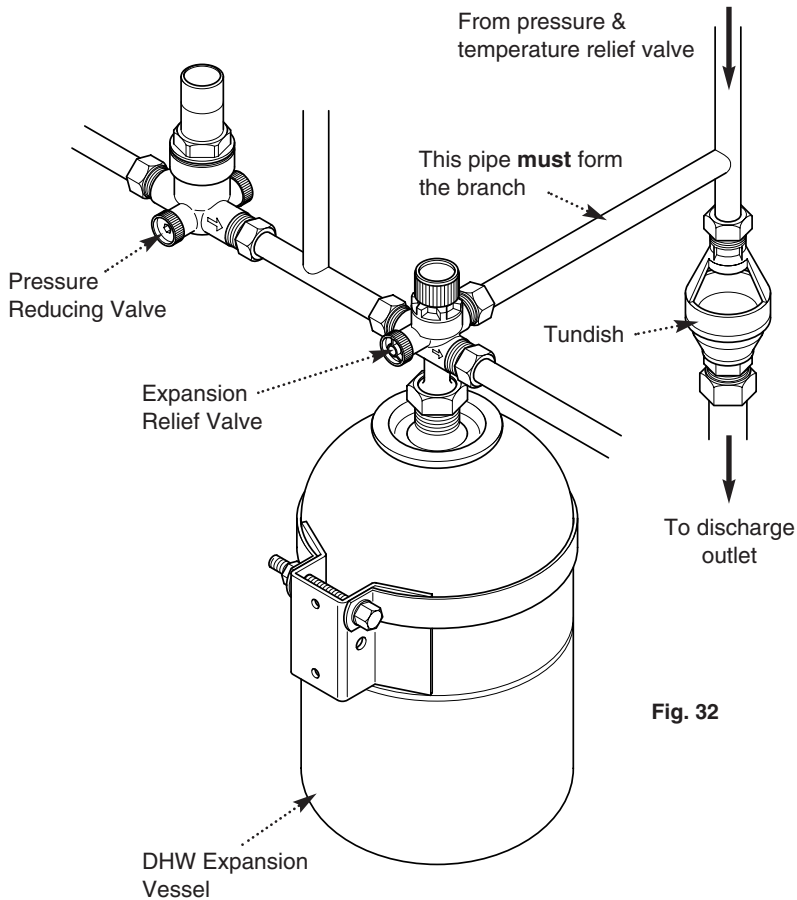

Fig. 32

Tundish can be positioned within shaded area. This allows a fall from the temperature and pressure relief valve and for 300mm vertical fall from tundish.

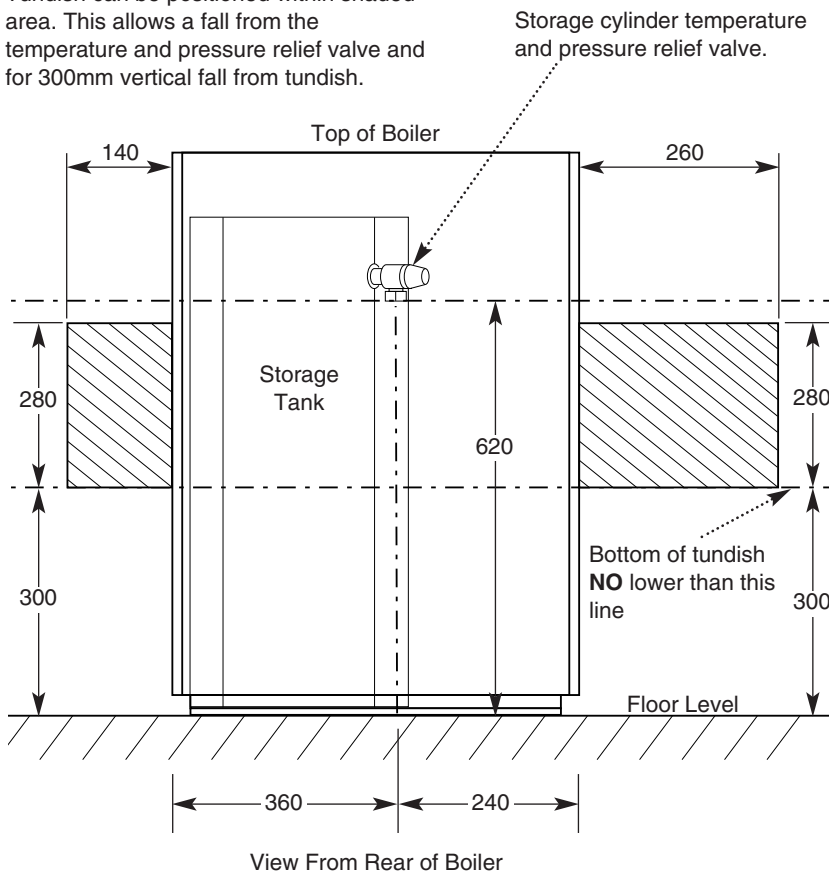

Fig. 33

1. The components supplied in the box marked "Unvented Kit" **MUST** be fitted to the mains water supply.
2. No isolating valves must be fitted between these components and the boiler.
3. The combined filter and pressure reducing valve must ideally be fitted before the mains water supply divides to feed the boiler and the rest of the dwelling. The pressure reducing valve is suitable for use at inlet pressures up to a maximum of 16bar.
4. The discharge pipes from the expansion relief valve supplied in the kit and the temperature/pressure relief valve on the boiler storage cylinder must be routed to the tundish supplied.
5. These discharge pipes must be 15mm, and the pipe downstream of the tundish at least 22mm.
6. The DHW expansion vessel is charged to 3.5bar, the DHW expansion relief valve set at 6bar.
7. See the instructions supplied in the unvented kit for further details.

8.7 Positioning the Tundish (Fig. 33)

1. The tundish must be within 500mm of the temperature/pressure relief valve when viewed in a horizontal plane.
2. Downstream from the tundish the discharge pipe must fall vertically for a minimum of 300mm. The discharge pipe must fall continuously over the entire length from temperature/pressure relief valve to final discharge point.
3. The discharge from the D.H.W. expansion vessel may join the temperature/pressure discharge upstream of the tundish. The D.H.W. expansion vessel discharge must branch into the temperature/pressure discharge pipe i.e. the main discharge is the temperature/pressure pipe.
4. In order to route the discharge pipe from the storage cylinder it is possible to slacken the nut on the cylinder and angle the temperature/pressure relief valve accordingly.
5. The tundish can be positioned in the shaded areas as shown in Fig. 33. Refer also to the instructions supplied with the Unvented Kit and Building Regulations Document G3.

8.0 Installation

8.8 Discharge Pipe

| Valve outlet size | Minimum size of discharge pipe D1 | Minimum size of discharge pipe D2 from tundish | Maximum resistance allowed, expressed as a length of straight pipe (i.e. no elbows or bends) | Resistance created by each elbow or bend |
|-------------------|-----------------------------------|--|--|--|
| G 1/2 | 15mm | 22mm 28mm 35mm | up to 9m up to 18m up to 27m | 0.8m 1.0m 1.4m |
| G 3/4 | 22mm | 28mm 35mm 42mm | up to 9m up to 18m up to 27m | 1.0m 1.4m 1.7m |
| G 1 | 28mm | 35mm 42mm 54mm | up to 9m up to 18m up to 27m | 1.4m 1.7m 2.3m |

Table 2

Worked Example of Discharge Pipe Length Calculation

- The example is for a G 1/2 temperature relief valve with a discharge pipe (D2) having 4 elbows and an actual length of 7.0m from the tundish to the point of discharge. From Table 2:-
- The maximum equivalent resistance of a length of 22mm discharge pipe (D2) from a G 1/2 temperature relief valve is 9.0m.
- The equivalent resistance of 4 x 22mm elbows at 0.8m each is 3.2m. Subtract this from the total permissible equivalent length i.e. 9.0m - 3.2m = 5.8m

- Therefore the maximum permissible actual length of 22mm pipe when including 4 elbows is 5.8m. As this is less than the actual length required (7.0m) a calculation must be performed for the next largest size.
- The maximum equivalent resistance of a length of 28mm discharge pipe (D2) from a G 1/2 temperature relief valve is 18.0m.
- The equivalent resistance of 4 x 28mm elbows at 1.0m per bend is 4.0m. Subtract this from the total permissible equivalent length i.e. 18.0m - 4.0m = 14.0m.
- As the actual length is 7.0m a 28mm discharge pipe (D2) will be adequate.

1. The discharge pipe from the tundish should terminate in a safe place where there is no risk to persons in the vicinity of the discharge, be of metal and:-

- Be at least one pipe size larger than the nominal outlet size of the safety device unless its total equivalent hydraulic resistance exceeds that of a straight pipe 9m long i.e. discharge pipes between 9m and 18m equivalent resistance length should be at least 2 sizes larger than the nominal outlet size of the safety device, between 18m and 27m at least 3 sizes larger, and so on. Bends must be taken into account in calculating the flow resistance. See Table 2.

- Have a vertical section of pipe at least 300mm long below the tundish before any elbows or bends in the pipework.

- Be installed with a continuous fall.

- Have discharges visible at both the tundish and the final point of discharge but where this is not possible or practically difficult there should be clear visibility at one or other of these locations. Examples of acceptable discharge arrangements are:

i) Ideally below a fixed grating and above the water seal in a trapped gully.

ii) Downward discharges at a low level, i.e. up to 100mm above external surfaces such as car parks, hard standings, grassed areas etc. are acceptable providing that where children may play or otherwise come into contact with discharges, a wire cage or similar guard is positioned to prevent contact, whilst still maintaining visibility.

iii) Discharges at high level, e.g. in to metal hopper and metal down pipe with the end of the discharge pipe clearly visible (tundish visible or not) or onto a roof capable of withstanding high temperature discharges of water and 3m from any plastic guttering systems that would collect such discharges (tundish visible).

iv) Where a single pipe serves a number of discharges, such as in blocks of flats, the number served should be limited to not more than 6 systems so that any installation can be traced reasonably easily. The single common discharge pipe should be at least one pipe size larger than the largest individual discharge pipe to be connected. If unvented hot water storage systems are installed where discharges from safety devices may not be apparent, i.e. in dwellings occupied by blind, infirm or disabled people, consideration should be given to the installation of an electronically operated device to warn when discharge takes place.

Note: The discharge will consist of scalding water and steam. Asphalt, roofing felt and non-metallic rainwater goods may be damaged by such discharges.

2. See Figs. 33a and 33b for examples of typical discharge pipe terminations.

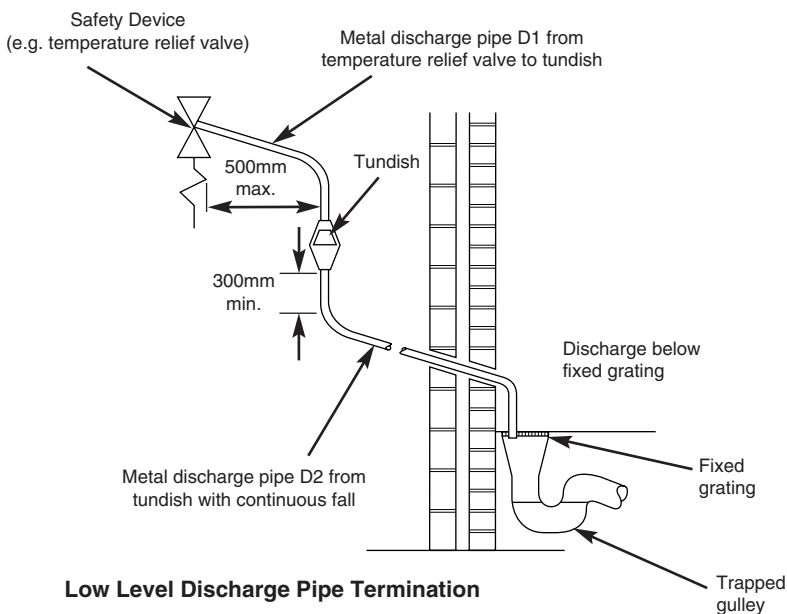

Low Level Discharge Pipe Termination

Fig. 33a

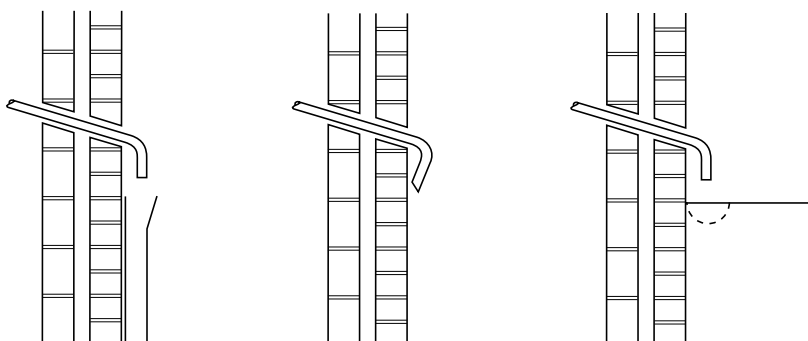

Termination into a hopper

Wall Termination

Termination into a gully

Fig. 33b

Alternative Discharge Pipe Terminations

8.0 Installation

8.9 Making The Electrical Connections

To connect the mains input cable proceed as follows:-

1. Pull the upper corners of the outercase front panel forwards. Draw the panel upwards to disengage it from the locating lugs (Fig. 37).
2. Remove the screws securing the wiring cover panel and disconnect the earth lead from the spade terminal on the rear of the panel (Fig. 36).
3. Route the input cable through the boiler ensuring that it will not come into contact with any hot surfaces (e.g. combustion box panels).
4. Remove the grommet at the extreme left of the electrical box. Cut off one of the moulded bosses to accept the input cable (Fig. 34).
5. Remove the screws from the cable clamp at the extreme left of the electrical box (Fig. 34).
6. Slacken the screws in the terminal block, connect the input cable, and tighten the screws. Replace the grommet in the electrical box and refit the cable clamp (Fig. 35).
7. If an external control is to be connected it can be done at this point (Fig. 35a). Run the input cable from the external control through the second from left cable clamp and the same grommet as the mains cable. Refer to the instructions supplied with the control.

8. To connect external control(s) remove the link between terminals 1 & 2. The 230V supply at terminal 1 must be connected to the external control. The switched output from the external control must be connected to terminal 2.

NOTE: If the room thermostat being used incorporates an anticipator it must be wired as shown in Fig. 35a.

IMPORTANT: The external control **MUST** be suitable for 230V switching.

9. If the optional integral timer is to be used it should be fitted at this point. Refer to the instructions supplied with the timer. **NOTE:** An external frost thermostat cannot be used with the integral timer.

8.10 Preliminary Electrical Checks

1. Prior to commissioning the boiler preliminary electrical system checks should be carried out.
2. These should be performed using a suitable meter, and include checks for Ground Continuity, Resistance to Ground, Short Circuit and Polarity.

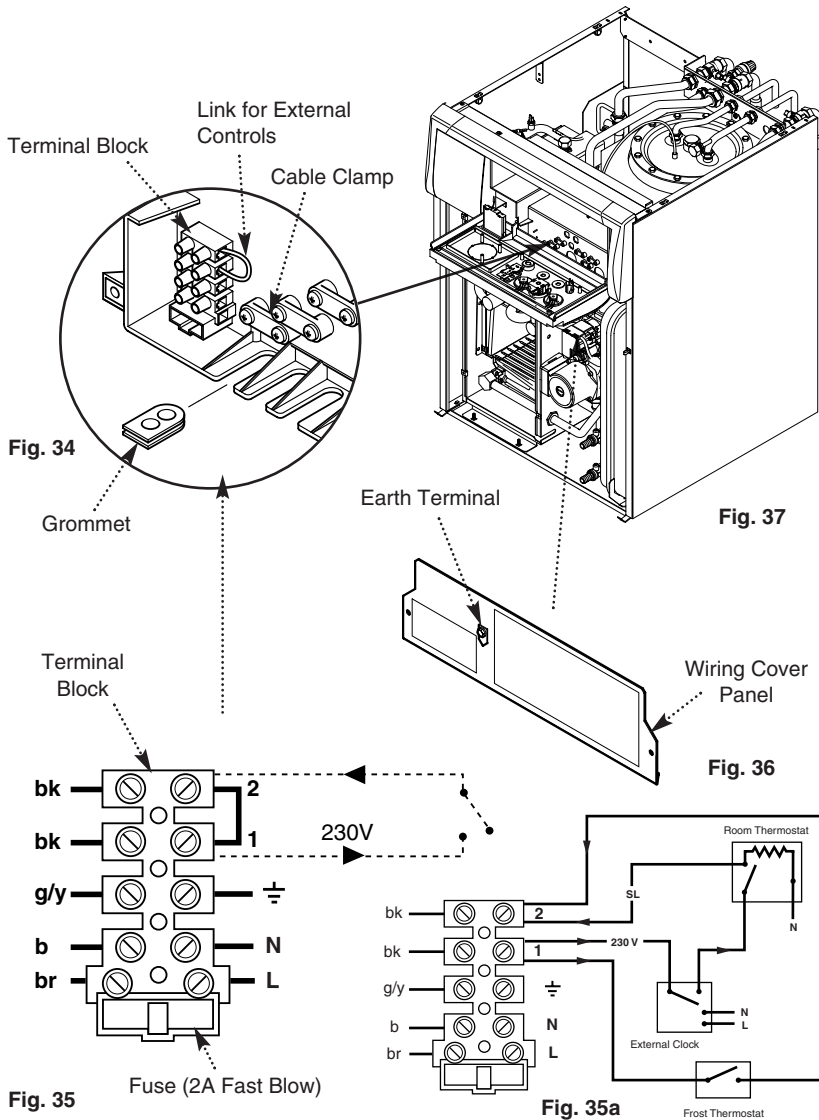

IMPORTANT: If an integral timer is fitted to the boiler an external frost thermostat wired as shown will not operate correctly. Only external timers may be used in such installations, as in the diagram.

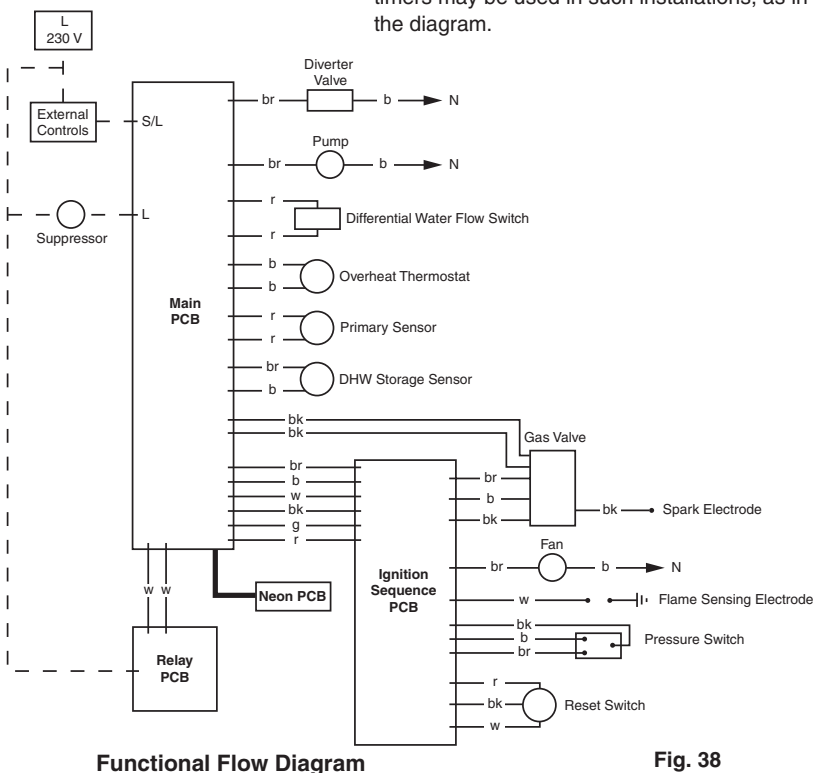

9.0 Commissioning the Boiler

9.1 Commissioning the Boiler

- Reference should be made to BS 5449 Section 5 when commissioning the boiler.
- Open the mains water supply to the boiler.
- Open all hot water taps to purge the DHW system.
- Ensure that the filling loop is connected and open, then open the heating flow and return valves on the boiler.
- Open the automatic air vent (Fig. 41).
- The system must be flushed in accordance with BS 7593 (see Section 6.2) and the flushing agent manufacturers instructions.
- Pressurise the system to 1.0 bar then close and disconnect the filling loop.
- Turn the gas supply on and purge the system according to BS 6891.
- Test for gas soundness.
- If at any time during commissioning it is required to terminate a particular cycle, e.g. the pump overrun period, turn the selector to the OFF position and then back to either (ON) or (OFF).

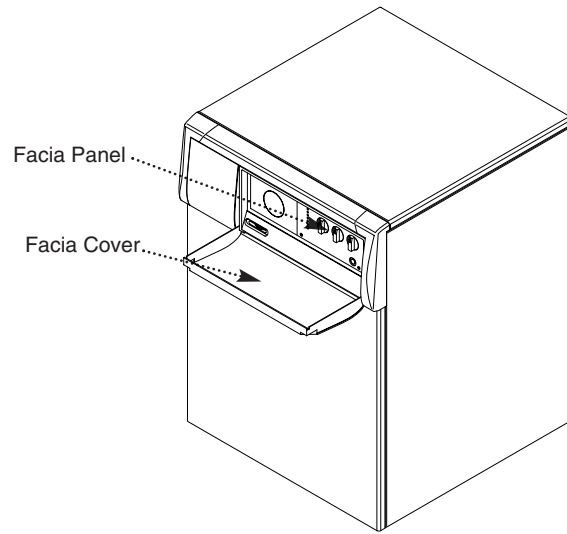

Hot Water Temperature Control Central Heating Temperature Control

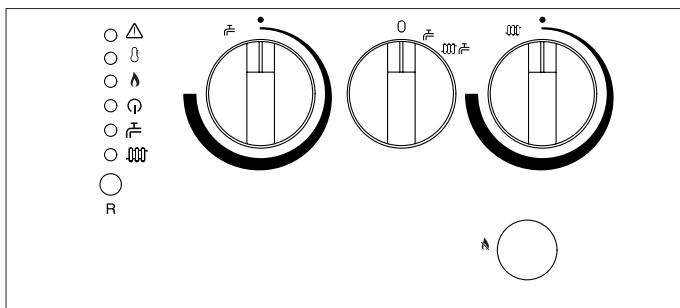

ON/OFF Selector Switch

Fig. 39

9.2 Checking the Burner Pressures

- Turn on the gas and electrical supplies to the boiler and ensure that all external controls are calling for heat.
- Set the hot water temperature control to maximum and the selector switch to the OFF position (Fig. 39). Draw off all hot water to ensure that the store is cold.
- Slacken the pressure test point sealing screw and connect a pressure gauge. Disconnect the sensing pipe from the spigot adjacent to the pressure test point (Fig. 40B).
- Turn the selector switch to the Domestic Hot Water position and open a hot water tap to give a flow rate of at least 10l/min.
- Remove the plastic cap and using a suitable spanner adjust the brass nut to give a maximum output setting pressure of 10.6 mbar (Fig. 40A).
- Disconnect one of the modulator wires from the gas valve. Adjust the red screw to achieve the correct minimum output setting pressure of 1.7 mbar (Fig. 40A).
- Turn the boiler off and reassemble in reverse order. Tighten the pressure test point sealing screw and reconnect the sensing pipe.
- The system should then be flushed again in accordance with BS 7593 and the flushing agent or inhibitor manufacturers instructions.

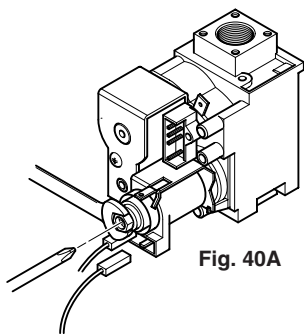

Fig. 40A

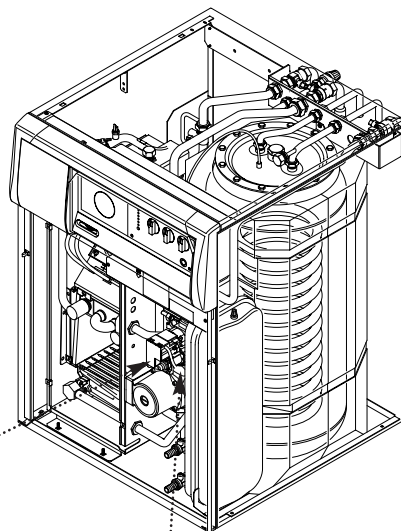

Fig. 40

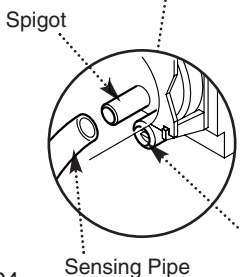

Fig. 40B

Burner Pressure Test Point

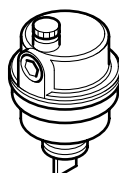

Fig. 41

Automatic Air Vent

9.0 Commissioning the Boiler

9.3 Completion

1. Flush the system again and treat it in accordance with BS7593 and the flushing agent and inhibitor manufacturer's instructions.

2. Set the adjustable pointer on the pressure gauge to 1 bar (Fig. 42).

3. Fill in the required details on the warning label fixed to the rear of the outcase front panel.

4. Carefully read and complete all sections of the "Benchmark" Installation, Commissioning and Service Record Log Book that are relevant to the appliance and installation. The details of the Log Book will be required in the event of any warranty work. The Log Book must be handed to the user for safe keeping and each subsequent regular service visit recorded.

5. Instruct the user in the operation of the boiler controls. Hand over the User's Operating, Installation and Servicing Instructions and the Log Book, giving advice on the necessity of regular servicing.

6. Show the user the position of the tundish and discharge pipe.

7. Refit the outcase top and front panels and close the fascia cover panel.

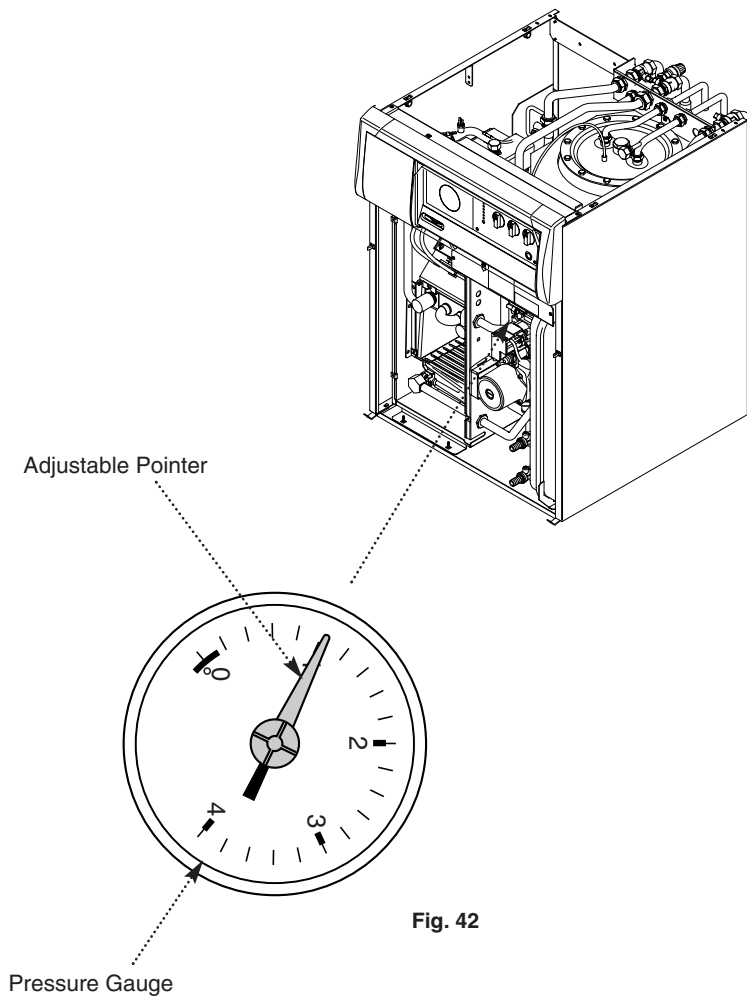

Fig. 42

10.0 Servicing the Boiler

10.1 Annual Servicing

1. For reasons of safety and economy, it is recommended that the boiler is serviced annually. Servicing must be performed by a competent person.

NOTE: The boiler incorporates a sample point in the flue adaptor - see Fig. 25.

2. After servicing, complete the relevant section of the "Benchmark" Installation, Commissioning and Service Record Log Book. This should be in the possession of the user.

3. Ensure that the boiler is cool.

4. Ensure that both the gas and electrical supplies to the boiler are isolated.

5. Pull the upper corners of the outcase front panel forwards. Draw the panel upwards to disengage it from the locating lugs (Fig. 43).

6. Undo the screws securing the combustion box front panel. Remove the panel (Fig. 44).

7. Undo the screws securing the combustion box inner panel. Remove the panel and examine the insulation piece (Fig. 44).

8. At the lower right of the combustion box undo the nut connecting the burner feed pipe to the gas inlet, being careful not to damage the seal (Fig. 45).

9. Draw the burner out of the combustion box and disconnect the spark lead and flame sensing lead from the electrodes (Fig. 45).
(cont.)

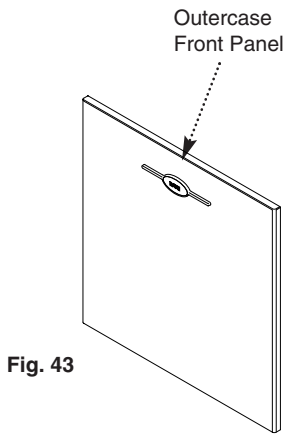

Fig. 43

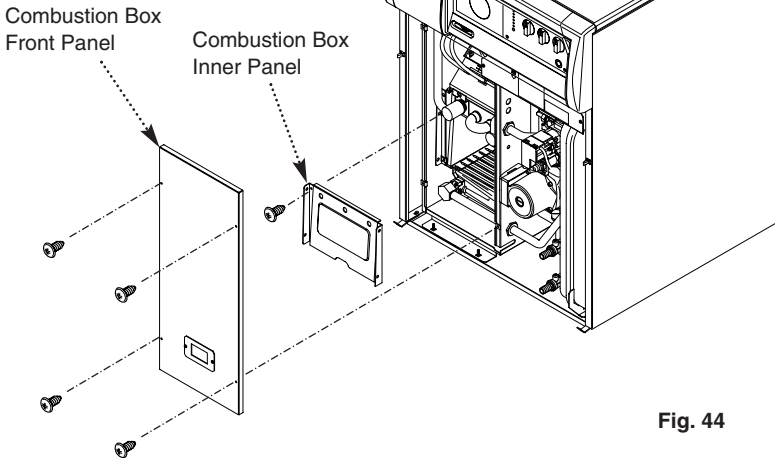

Fig. 44

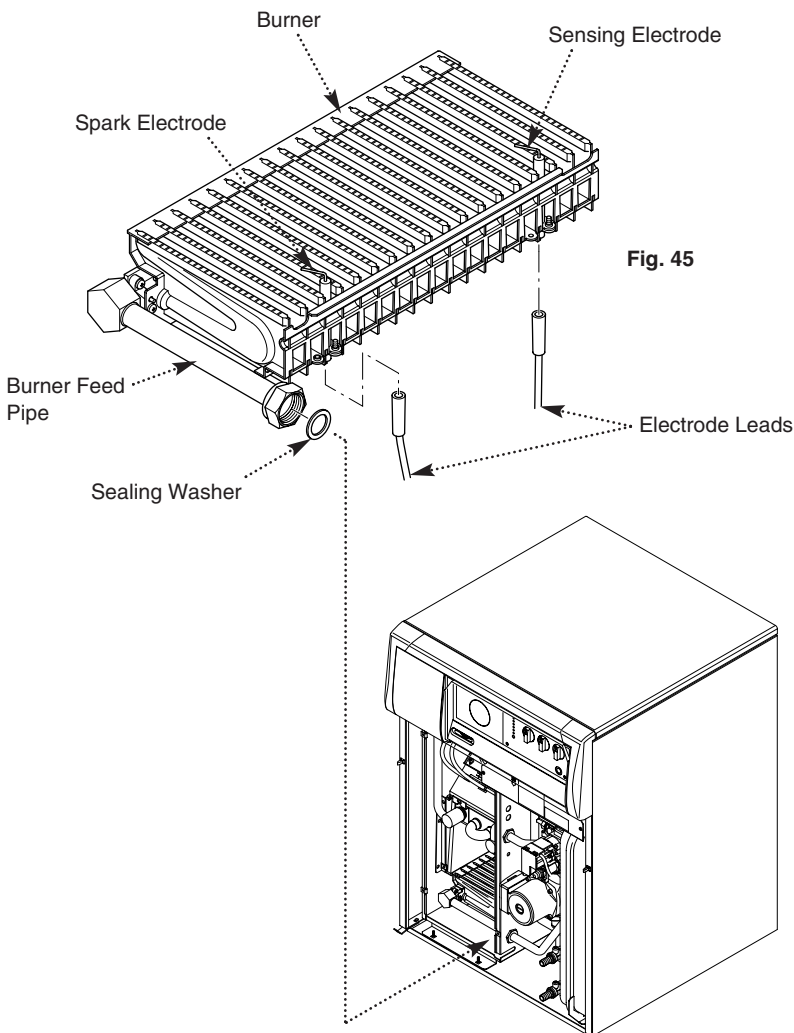
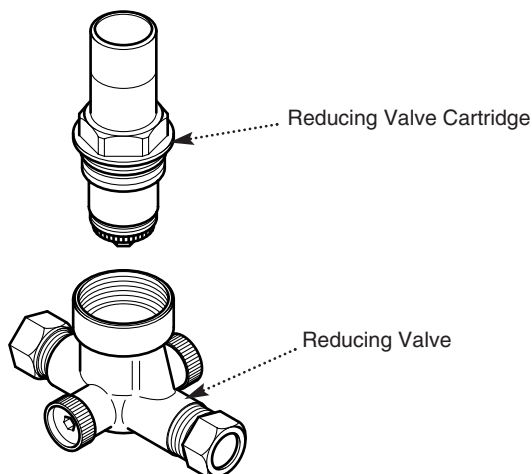
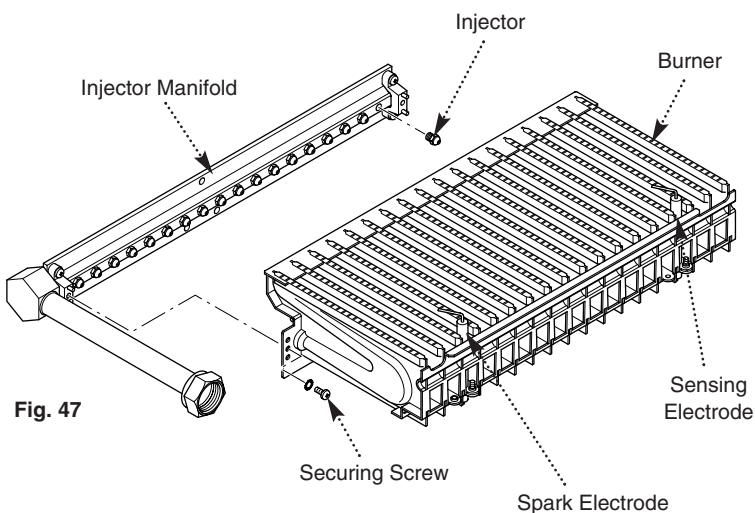
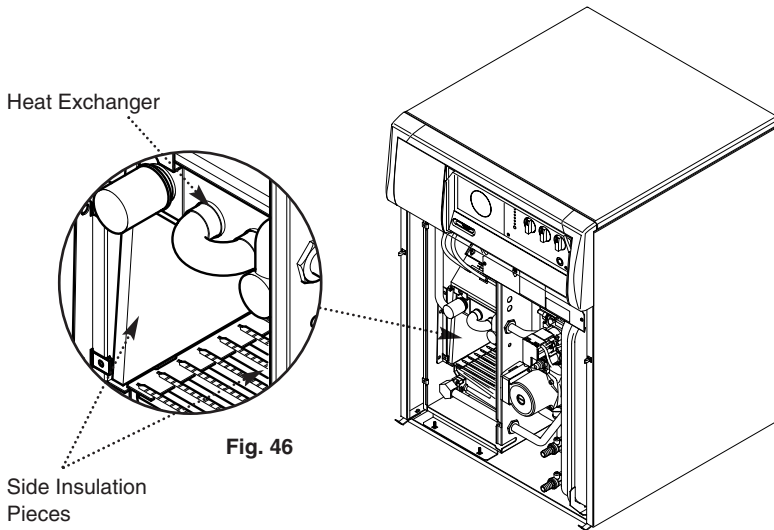

Fig. 45

10.0 Servicing the Boiler

10.1 Annual Servicing (Cont.)



10. Gently clean the underside of the heat exchanger with a soft brush, taking care not to damage any of the fins.

NOTE: To gain access to the top of the heat exchanger for cleaning purposes see Section 11.2 of Changing Components, which includes details of removing the fan.

11. Inspect the side insulation pieces and replace if they are damaged or deteriorated in any way and carefully brush out any debris or deposits from the combustion box (Fig. 46).

12. Undo the screws securing the injector manifold to the burner assembly and remove the manifold. Examine the injectors for blockage, cleaning as necessary. Do not use hard tools, such as pins or wire (Fig. 47).

13. Clean the burner with a soft brush taking care not to damage the electrodes. Check the condition, positions and gaps of the electrodes.

14. The pressure reducing valve should not require any maintenance on an annual basis, but if problems are experienced with pressure the cartridge should be cleaned.

Cleaning The Cartridge

15. Turn off the mains water supply. Unscrew the cartridge from the valve body and rinse thoroughly in clean water (Fig. 48).

16. Check the primary system pressure vessel charge and system pressure, and the d.h.w. pressure vessel charge. Re-pressurise as necessary.

17. Turn the heads of the temperature/pressure relief valve, the d.h.w. pressure relief valve and primary system pressure relief valve **NOT MORE THAN 1/4 TURN** to ensure that they will open and reseat, and that any discharge pipework is clear.

NOTE: To test the valves as described above it is not necessary to turn the relief valve head "over centre" past the return cam.

18. Reassemble in reverse order of dismantling and recommission.

19. Complete the relevant section of the "Benchmark" Installation, Commissioning and Service Record Log Book and hand it back to the user.

11.0 Changing Components

IMPORTANT: When changing components ensure that both the gas and electrical supplies to the boiler are isolated before any work is started.

See Section 10.0 “Annual Servicing” for removal of case panel and combustion box door.

11.1 Pressure Switch (Fig. 49)

1. Note the positions of the two sensing tubes and three wires and remove them.
2. Undo the screws securing the pressure switch to the combustion box bracket and remove the switch.
3. Fit the new component in reverse order of dismantling and connect the sensing tubes and wires as previously noted (see Service Guidance label on reverse of front panel).

11.2 Fan

IMPORTANT: The replacement fan may be of a different type to the original. The mounting plate accommodates both types and the fitting procedure is the same.

1. Note the position of the wires and pipes on the pressure switch and remove them. Note the position of the fan wires and disconnect them (Fig. 50).
2. Roll the flue seal back over itself onto the adaptor spigot (Fig. 51).
3. Undo the screws securing the fan mounting plate to the hood. Draw the fan and plate assembly out of the boiler (Fig. 50).
4. Remove the fan securing screws and separate the mounting plate and fan. Remove the screws securing the fan elbow to the original fan. Carefully draw the elbow out, examining the seal for damage (Fig. 50).
5. Fit the elbow to the new fan, ensuring that the seal is in position. Secure the new fan to the mounting plate and reassemble in reverse order (Fig. 50).
6. Roll the flue seal back over the joint between the fan elbow and adaptor spigots (Fig. 52).

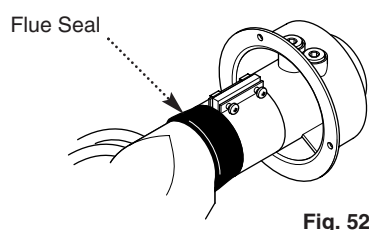
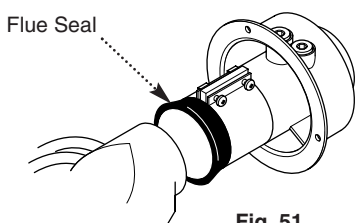
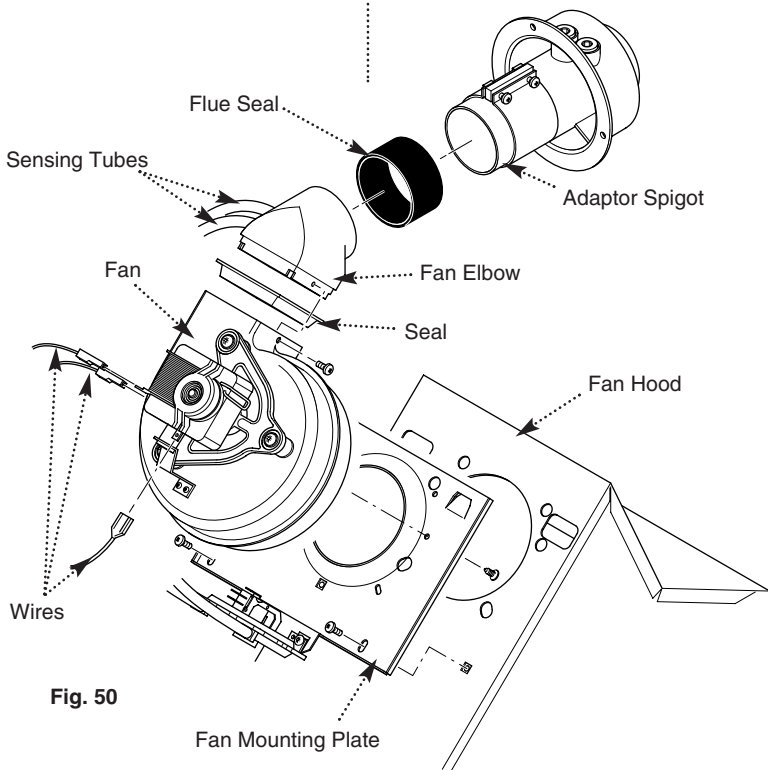
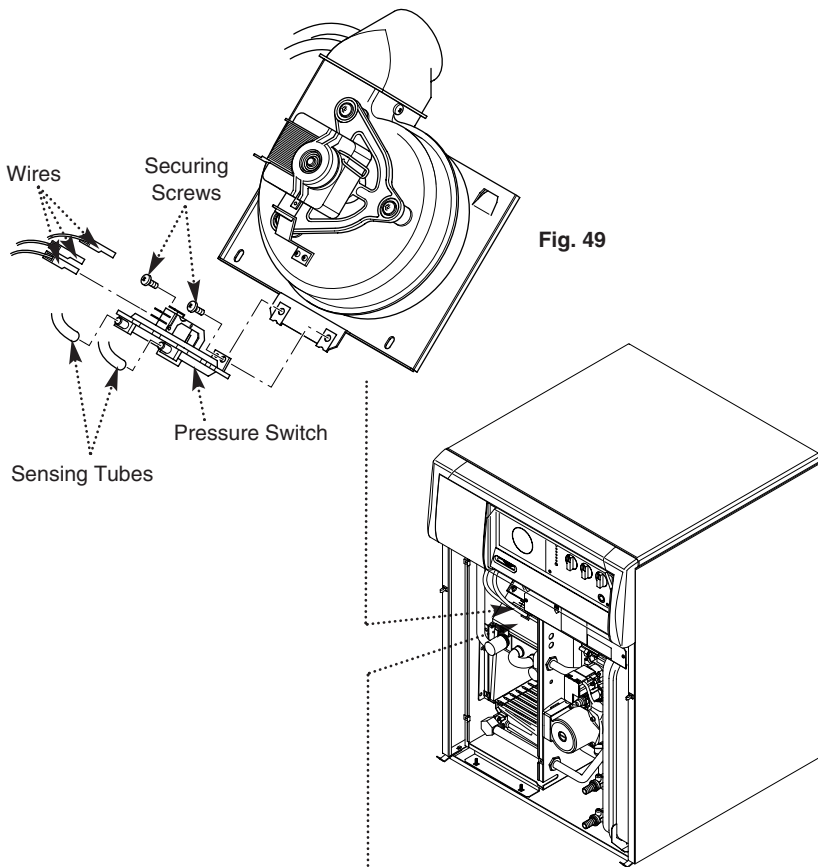

11.0 Changing Components

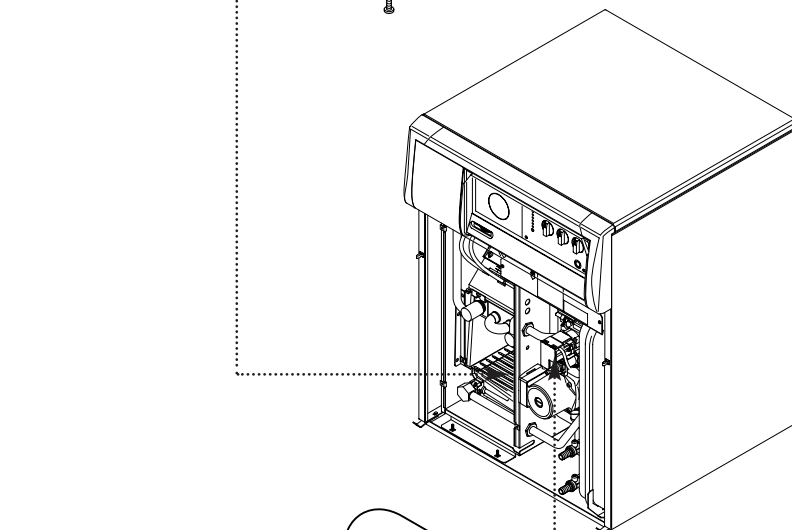
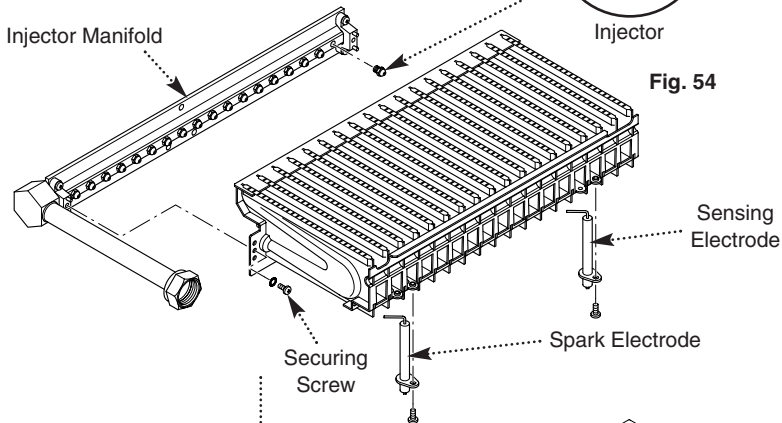
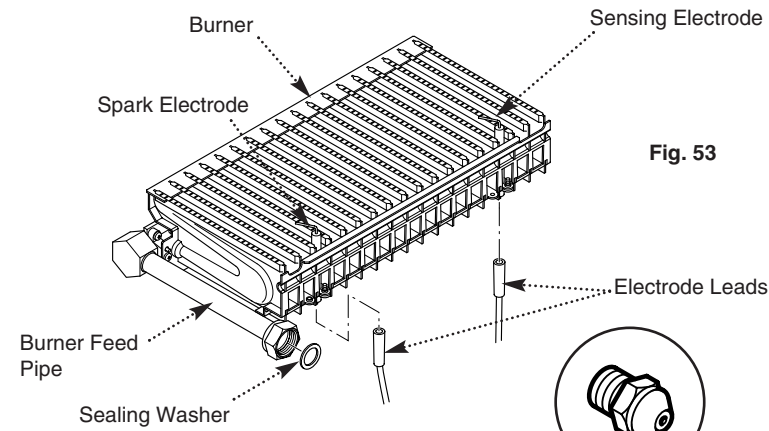

11.3 Burner (Fig. 53)

1. Undo the screws securing the combustion box inner panel. Remove the panel and examine the insulation piece.
2. At the lower right of the combustion box undo the nut connecting the burner feed pipe to the gas inlet, being careful not to damage the seal.
3. Draw the burner out of the combustion box and disconnect the ignition lead and flame sensing lead from the electrodes.
4. Undo the screws securing the injector manifold to the burner assembly and remove the manifold.
5. Undo the screws securing the electrodes to the burner assembly and remove them.
6. Fit the electrodes and injector manifold to the new burner and check the electrode positions. Reassemble in reverse order.

11.4 Electrodes (Fig. 54)

1. Remove the burner as described in section 11.3 and undo the screw securing the relevant electrode to the burner assembly and remove.
2. Check the electrode positions and reassemble in reverse order.

11.5 Injectors (Fig. 54)

1. Remove the burner as described in section 11.3 and undo the screws securing the injector manifold to the burner assembly and remove the manifold.
2. Unscrew and replace injectors as required and reassemble in reverse order.

11.6 Gas Valve (Fig. 55)

1. Disconnect the wires from the valve modulator and the sensing pipe and earth wire from the valve body.
2. Note the position of the ignition lead and earth wire on the valve NAC and disconnect them. Undo the screw securing the NAC to the valve and draw it away.
3. Using a suitable hexagon key undo the socket head screws securing the gas pipe flanges to the valve.
4. Remove the valve from the gas pipe. Examine the 'O' ring seals and replace if necessary.
5. Reassemble in reverse order and recommission the appliance. Check the burner pressure as described in Section 9.2.

11.0 Changing Components

11.7 Temperature Sensors

There are two sensors, one on the boiler flow pipe and one in the storage cylinder.

Flow Pipe Sensor (Fig. 56)

1. To replace the flow pipe sensor ease the retaining tab away and disconnect the electrical plug.
2. Unscrew the sensor from it's pocket. Fit the new sensor, applying a suitable amount of heat transfer paste to the pocket if necessary. Reconnect the plug.

Storage Cylinder Sensor (Fig. 58)

1. The storage cylinder sensor is connected to the main P.C.B. by the same multi-pin plug as the flow pipe sensor wires. These items cannot be separated and are replaced as one.

2. Remove the screws securing the wiring cover panel (Fig. 57) and disconnect the earth lead from the spade terminal on the rear of the panel. Remove the extreme right cable clamp from the wiring loom and ease the grommet out of the electrical box.

3. Hinge the facia cover panel down. Remove the facia securing screws and allow the facia to hinge down. Disconnect the multi pin plug from terminal M11 on the main P.C.B. and remove the cable ties from the sleeve.

4. Pull the storage cylinder upper insulation foam to one side and remove the cable tie retaining the sensor in the storage cylinder pocket.

5. Disconnect the plug from the flow sensor. Take the multi pin plug and, whilst holding the sleeve, carefully pull out the cylinder sensor and wires.

6. Pass the replacement cylinder sensor and flow sensor wires through the sleeve and secure using suitable cable ties or similar.

7. Connect the plug to the flow pipe sensor and insert the cylinder sensor into the pocket as far as it will go. Secure the cylinder sensor with a suitable cable tie or similar.

8. Reassemble in reverse order.

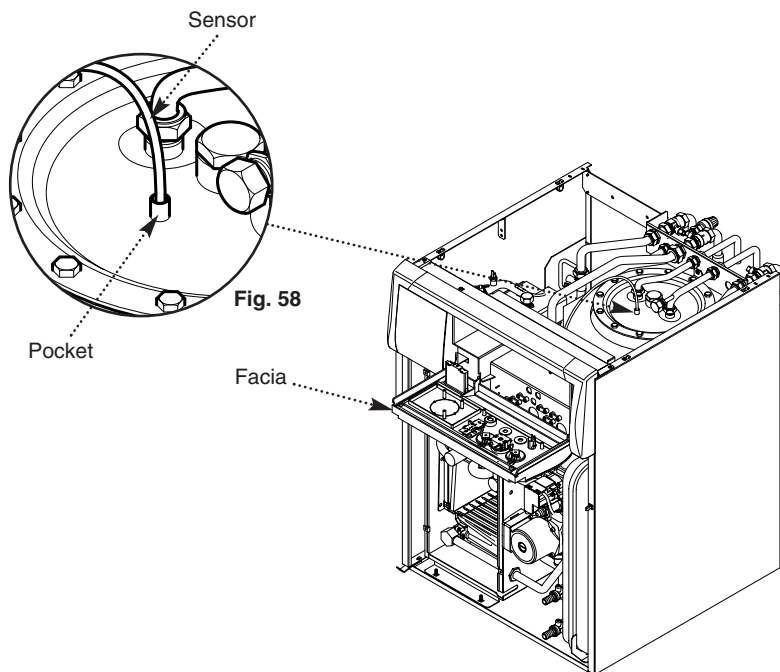
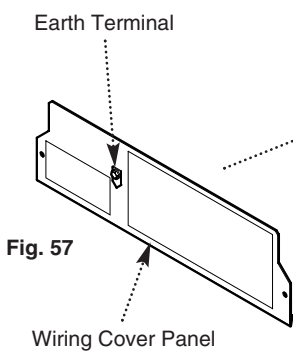
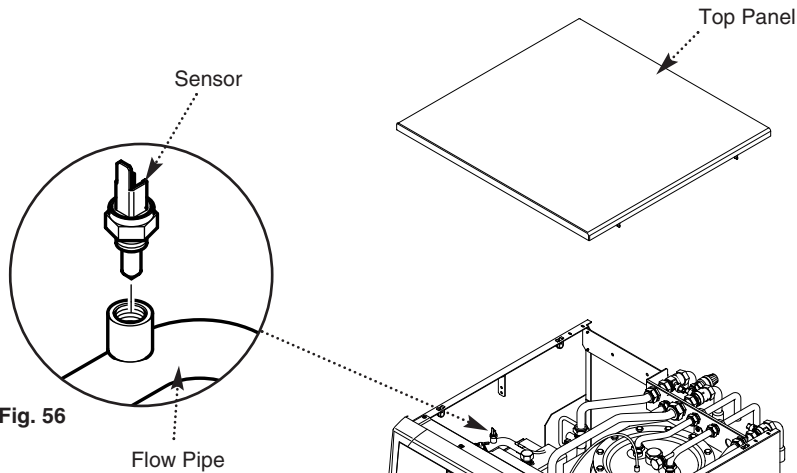

11.0 Changing Components

11.8 Pressure Gauge (Fig. 59)

1. Isolate the central heating system and drain the primary circuit. Hold the square section on the gauge with a suitable spanner.
2. Undo the nut securing the gauge to the return pipe. Remove the gauge and examine the sealing washer, replacing if necessary.
3. Reassemble in reverse order and repressurise the system.

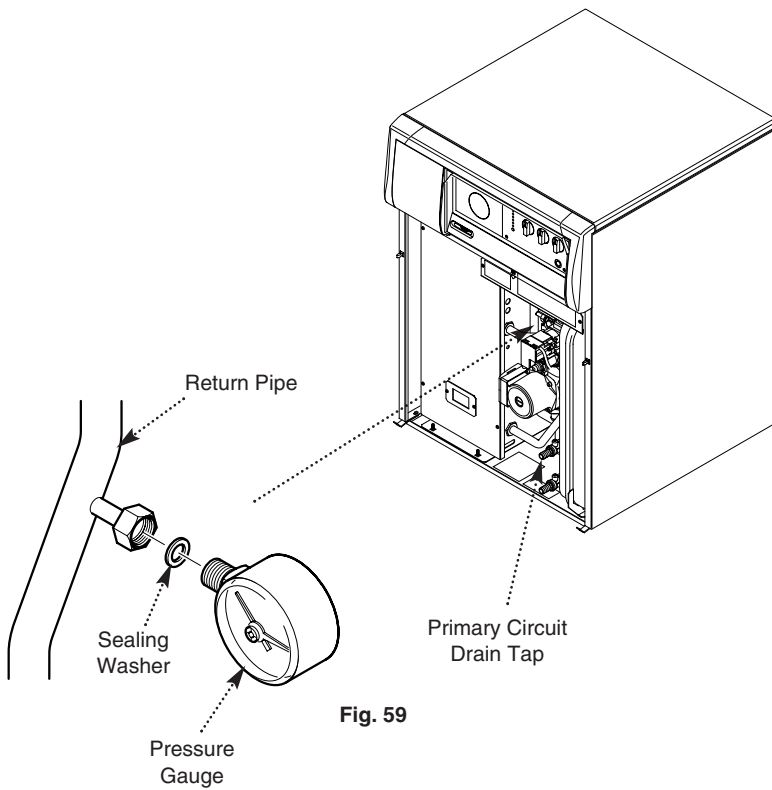

Fig. 59

11.9 Heat Exchanger (Figs. 60 & 61)

1. Isolate the central heating system and drain the primary circuit. Undo the screws securing the combustion box inner panel. Remove the panel and examine the insulation piece.
2. Using a suitable hexagon key slacken the grub screw securing the flow pipe boss to the heat exchanger.
3. Undo the flow pipe nut on the inside of the combustion box at the top left hand side. Ease the pipe clockwise so that it will clear the combustion box flange.
4. Undo the nut securing the sensing probe to the combustion box right hand side panel. Withdraw the probe.
5. Whilst supporting the heat exchanger, undo the return pipe nut on the inside of the combustion box at the lower right hand side.
6. Allow the heat exchanger to drop slightly and ease it forwards out of the combustion box taking care not to damage the side insulation pieces.
7. Pull the flow pipe off the left hand heat exchanger spigot. Slacken the grub screw in the return pipe boss and pull it off the right hand spigot.
8. Engage the flow and return pipes on the spigots of the new heat exchanger.
9. Identify the rectangular slots at the rear of the combustion box. Slide the heat exchanger into the combustion box taking care not to damage the side insulation pieces.
10. Manoeuvre the heat exchanger so that the rear manifolds locate in the rectangular slots at the rear of the combustion box.
11. Support the heat exchanger and connect the nuts on the flow and return pipes to the fittings in the combustion box. Ensure that the sealing washers are fitted, and not damaged in any way.
12. Tighten the grub screws in the flow and return bosses. Reassemble in reverse order and repressurise the system.

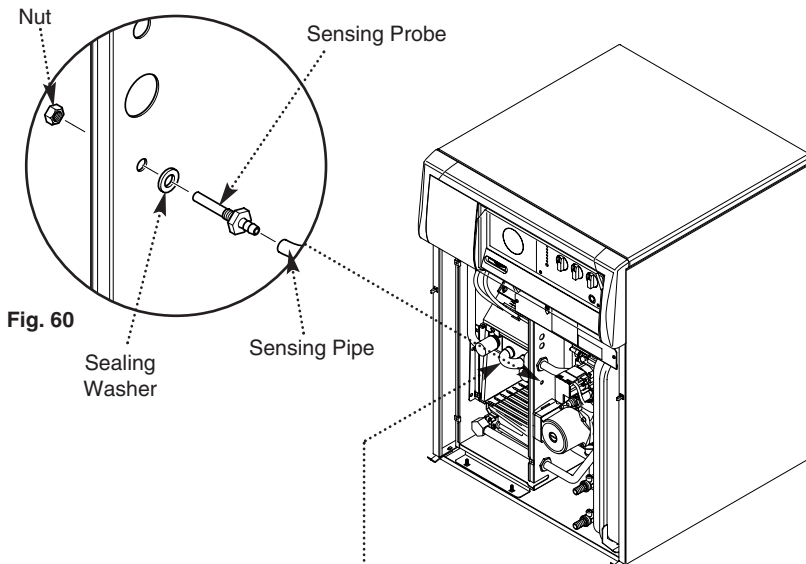

Fig. 60

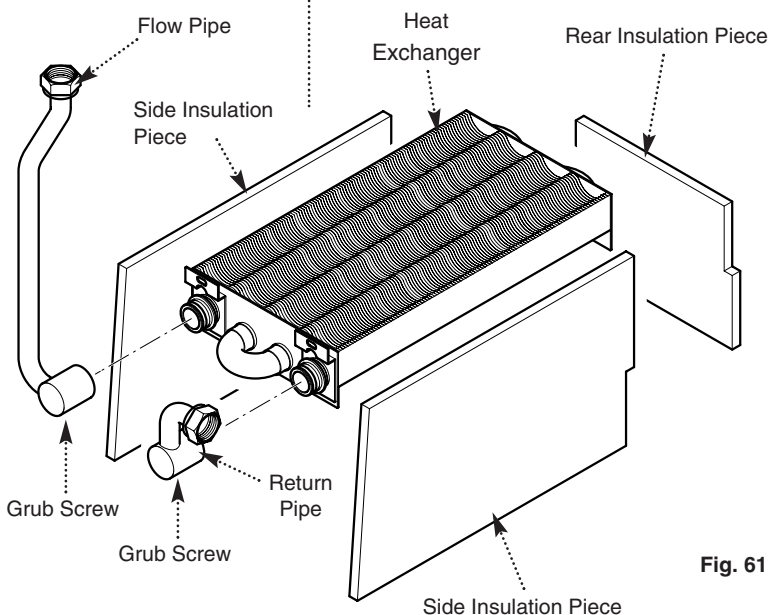

Fig. 61

11.0 Changing Components

11.10 Insulation (Fig. 62)

There are four insulation pieces in the combustion box - two side pieces, one rear and one front attached to the combustion box inner panel.

Front Piece

1. Undo the screws securing the combustion box inner panel. Remove the panel.

2. Disengage the insulation piece from the retaining tabs on the lower edge of the inner panel.

3. Fit the new insulation piece by carefully locating it behind the tabs and pushing back.

Side and Rear Pieces

1. To replace either side piece or the rear piece it is necessary to remove the heat exchanger as described in Section 11.9.

2. To remove either side piece undo the appropriate fan hood to combustion box screw. Pull the insulation forwards out of the combustion box, noting it's orientation.

3. It is necessary to remove both side pieces to replace the rear piece. Note the orientation of the rear piece and remove it.

4. When fitting the new rear piece ensure that it locates behind the burner end blade.

5. Refit the side pieces ensuring that they are not abraded against the combustion box side panels, captive nuts etc.

Completion

Carefully clean away any insulation from the combustion box and burner and reassemble in reverse order.

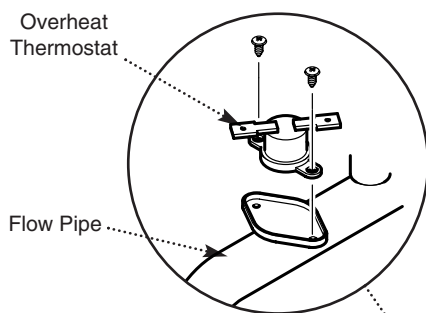
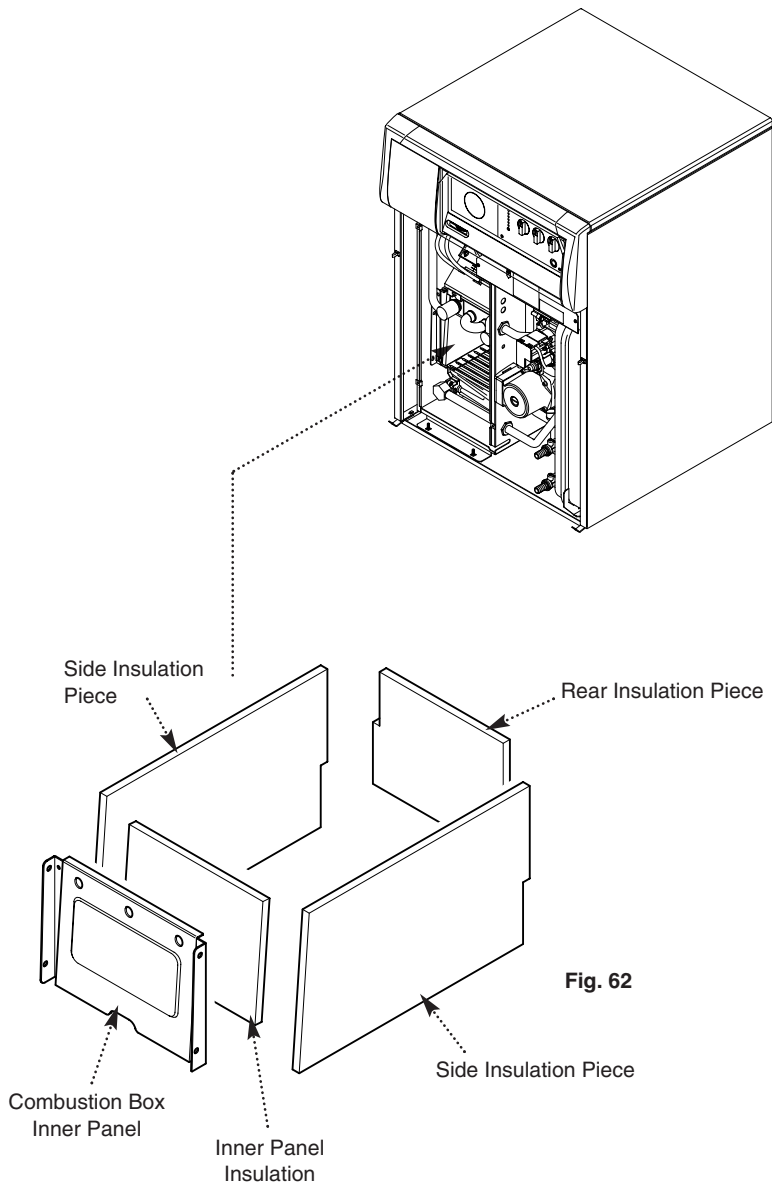

11.11 Overheat Thermostat (Fig. 63)

1. Pull the two electrical connections off the thermostat.

2. Remove the screws securing the thermostat to the mounting plate on the flow pipe.

3. Reassemble in reverse order. The thermostat is not polarised - either wire can fit either terminal on the thermostat.

11.0 Changing Components

11.12 Circuit Boards & Electrical Components (Fig. 64)

See section 12.0 "Illustrated Wiring Diagram" for the layout of all electrical components. To gain access hinge the facia cover panel down. Remove the facia securing screws and allow the facia to hinge down.

Neon PCB

1. Undo the screw securing the neon PCB to the control panel and disconnect the plug on the ribbon wiring from the main PCB.

2. Reassemble in reverse order.

Main PCB

1. Note the position of each plug and connector and remove them. Remove the PCB securing screws.

2. Carefully draw the PCB away from the electrical box.

3. Reconnect all plugs and connectors previously removed and reassemble in reverse order.

Relay PCB

1. Disconnect the plug from the PCB and undo the screw securing the PCB to the control panel.

2. Reassemble in reverse order.

Ignition Sequence PCB

1. Note the position of each plug and connector and remove them. Pull the earth wire off the earth grounding strip.

2. Undo the PCB securing screws and remove the board.

3. Reassemble in reverse order.

Suppressor

IMPORTANT: The new suppressor must be wired as shown to ensure correct operation of the boiler.

1. Remove the outercase top panel and undo the suppressor retaining nut and washer at the rear of the electrical box.

2. Remove each wire from the original suppressor one at a time and connect to the appropriate terminal on the new suppressor before disconnecting any further wires.

3. Locate the stud on the base of the suppressor through the hole in the electrical box and secure with the nut and washer previously removed.

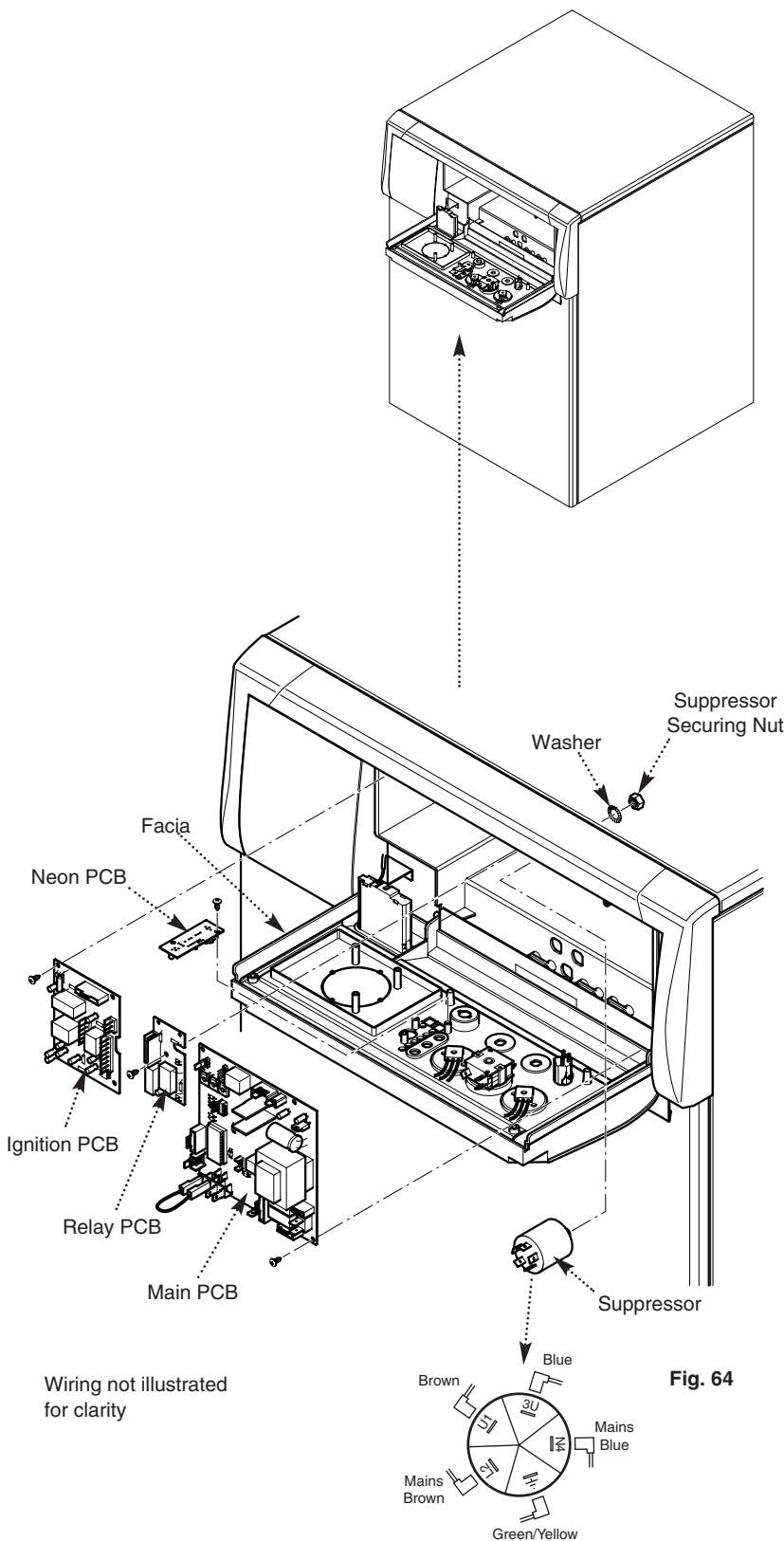

Fig. 64

11.0 Changing Components

11.12 Circuit Boards & Electrical Components (Cont.) (Fig. 65)

Selector Switch

1. Note the position of the wires and remove them.
2. Carefully pull off the selector control knob. Undo the securing screws and remove the switch from the facia.
3. Reassemble in reverse order.

Temperature Control Knob Potentiometers

1. Note their position and carefully pull off the temperature control knobs. Note the orientation of each potentiometer and undo their retaining locknuts and washers.
2. Disconnect the multi pin plug from terminal M12 on the main P.C.B. and remove the cable ties from the wiring harness.
3. Connect the new plug to terminal M12 and fit the potentiometers to the facia, ensuring their correct orientation.
4. Resecure the wiring harness with suitable cable ties or similar.
5. Refit the control knobs and adjust them to their previously noted settings. Reassemble in reverse order.

Flame Failure Reset Button

1. Note the position of the wires and remove them.
2. Depress the retaining barbs on the body of the reset button and draw it through the facia.
3. Fit the new button to the facia, connect the wires and reassemble in reverse order.

Temperature Gauge (Figs. 65 & 66)

1. Remove the outercase top panel and prise off the clip retaining the temperature gauge capillary to the flow pipe.
2. Depress the barbs on the side of the gauge. Draw the gauge and capillary out through the facia panel.
3. Reassemble in reverse order, applying a suitable amount of heat transfer paste to the flow pipe and capillary if required.

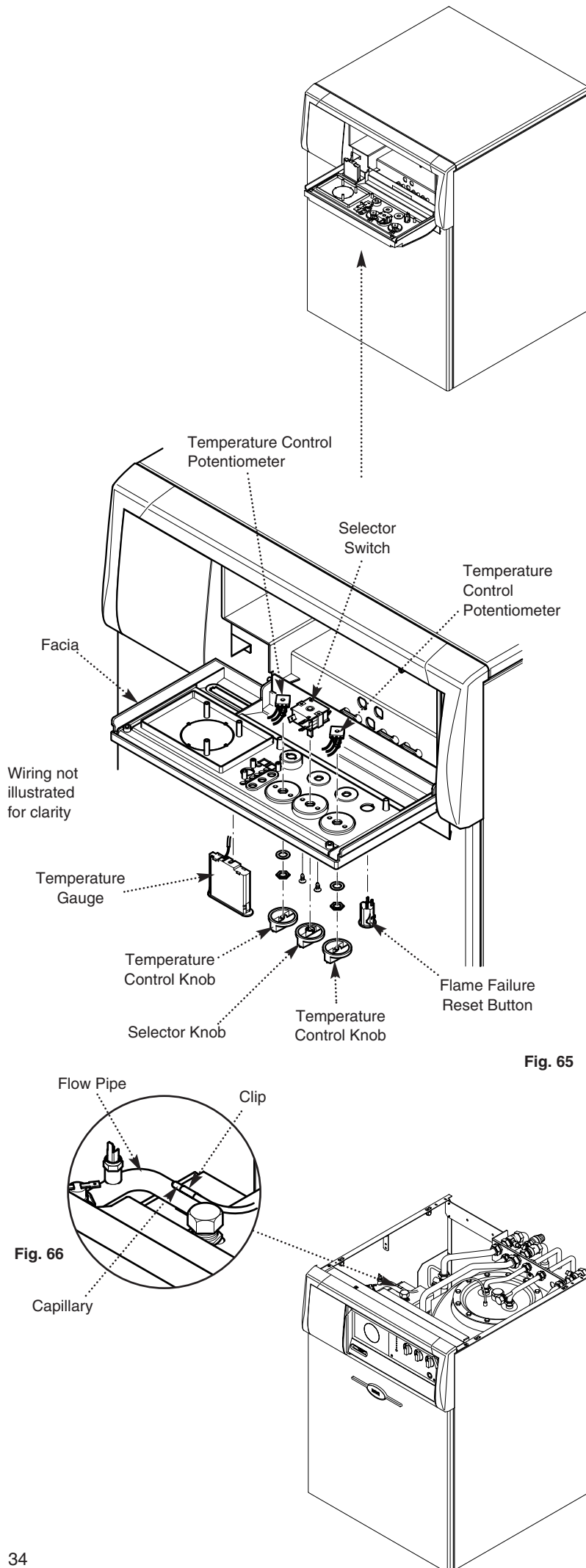

11.0 Changing Components

11.13 Diverter Valve - Head Only (Figs. 67 & 68)

1. Remove the outercase top panel and undo the screws securing the wiring cover panel. Disconnect the earth lead from the spade terminal on the rear of the panel.
2. Identify the diverter valve cable and remove the cable clamp. Ease the cable grommet out of the electrical box.
3. Hinge the facia cover panel down. Remove the facia securing screws and allow the facia to hinge down.
4. Disconnect the multi pin plug from terminal M3 on the main P.C.B. and earth lead from the earth grounding strip.
5. Carefully remove the grommet over the multi pin plug and earth lead.
6. Slacken the screw securing the valve operating head cover. Pull the cover off.
7. Undo the two screws retaining the operating head to the valve body. Draw the head upwards to separate it from the body. Remove it and the wiring from the boiler.
8. Fit the new head to the valve body and route the wiring to the electrical box. Feed the multi pin plug and earth lead through the grommet.
9. Engage the grommet in the electrical box, connect the plug to M3 on the main P.C.B. and earth lead to the earth grounding strip.
10. Refit the cable clamp and reassemble in reverse order.

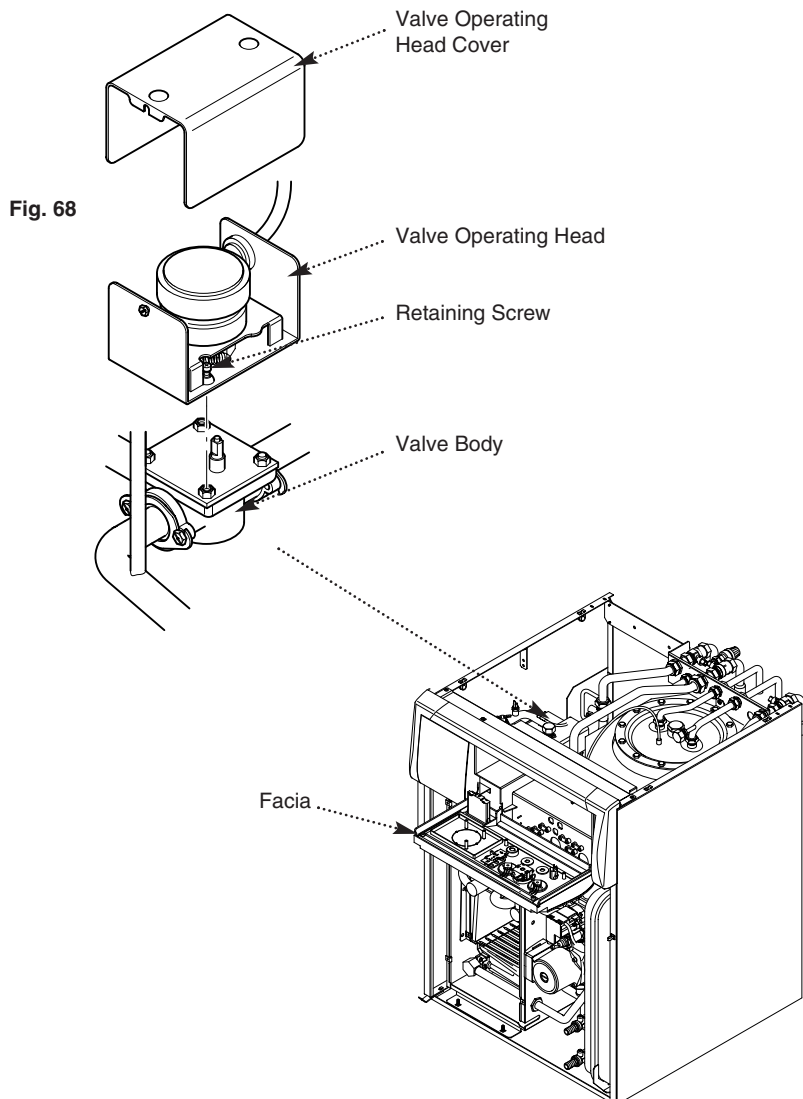
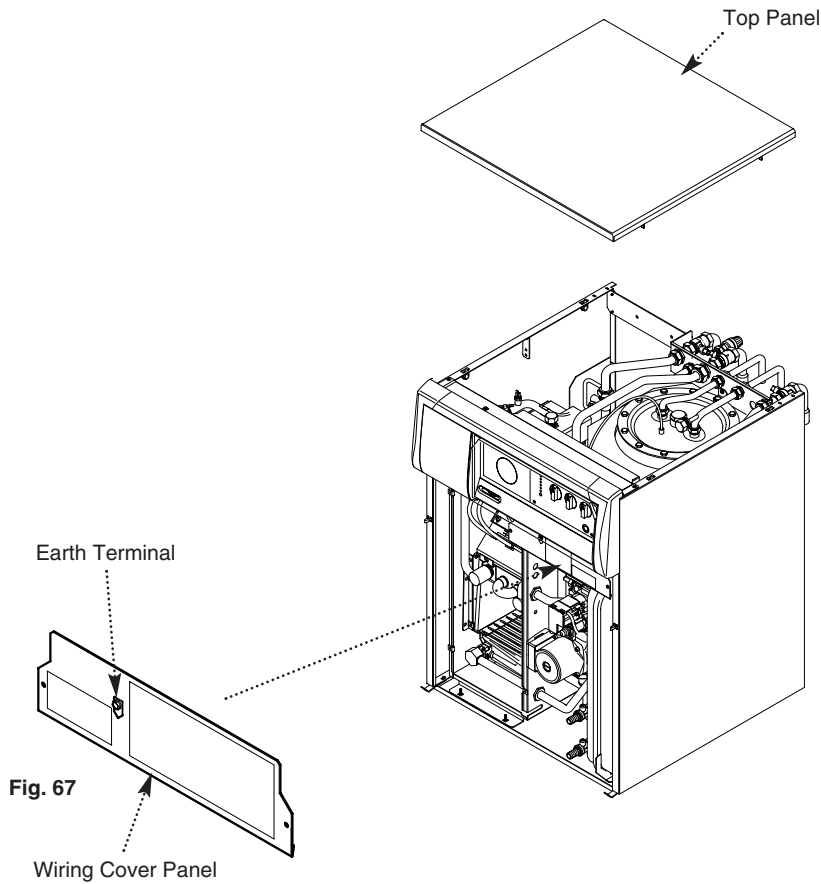

11.0 Changing Components

11.14 Diverter Valve - Complete (Figs. 69 & 70)

1. Remove the outcase top panel and undo the screws securing the wiring cover panel. Disconnect the earth lead from the spade terminal on the rear of the panel.
2. Identify the diverter valve cable and remove the cable clamp. Ease the cable grommet out of the electrical box.
3. Isolate the central heating system and drain the boiler primary circuit.
4. Hinge the facia cover panel down. Remove the facia securing screws and allow the facia to hinge down.
5. Disconnect the multi pin plug from terminal M3 on the main P.C.B. and earth lead from the earth grounding strip.
6. Carefully remove the grommet over the multi pin plug and earth lead.
7. Slacken the screws securing each washer and pipe flange to the valve. Rotate the washers and disengage them from the screws.
8. Undo the nut on the storage cylinder feed pipe. Disconnect the flange from the diverter valve outlet port and remove the pipe.
9. Undo the nuts on the central heating flow, return and pressure relief pipes at the tap rail. Disconnect the flanges from the diverter valve ports to allow removal of the valve.
10. Remove the valve and the wiring from the boiler.
11. Before fitting the new valve examine the 'O' ring seals on the pipe flanges, replacing if necessary.
12. Reassemble in reverse order and repressurise the system.

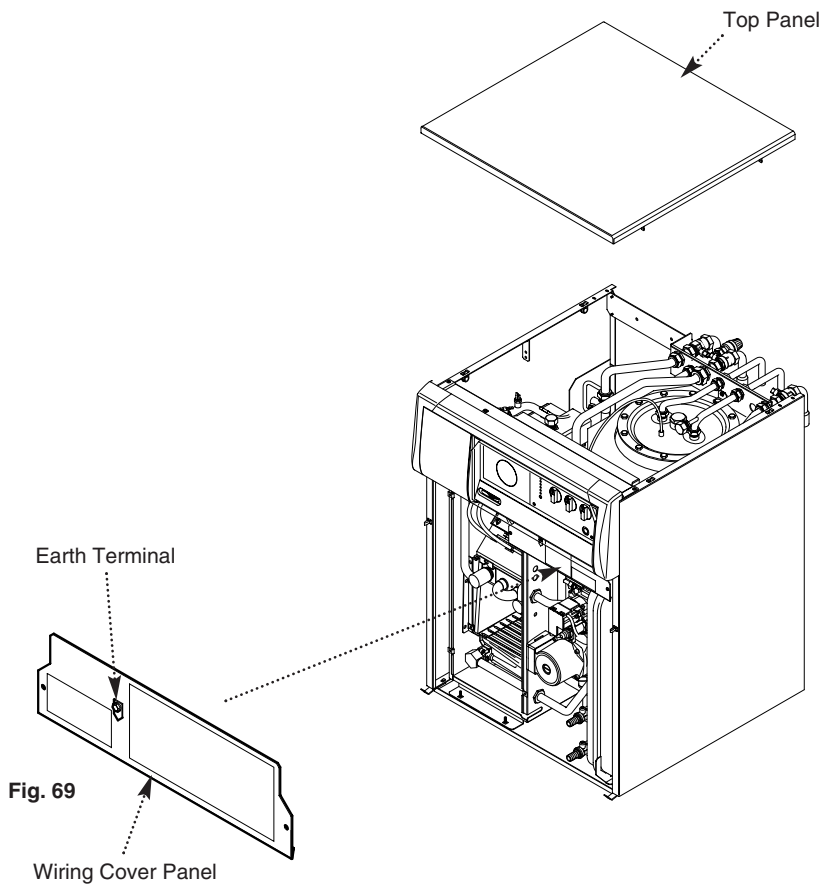

Fig. 69

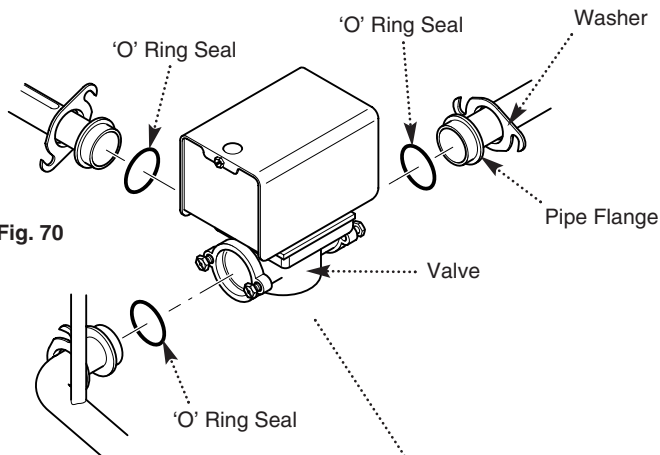
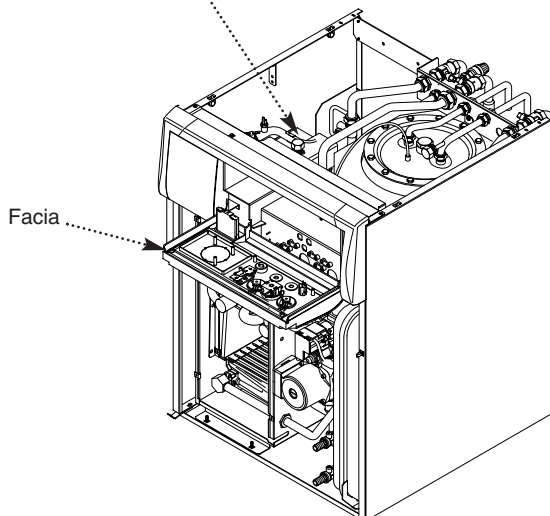

Fig. 70



11.0 Changing Components

11.15 Differential Pressure Switch (Figs. 71 & 72)

1. Remove the spring clip securing the switch sensing head to the switch body. Draw the head off the body.
2. Isolate the central heating system and drain the boiler primary circuit.
3. Undo the nuts on each pipe at the body of the pressure switch and remove it.
4. Reassemble in reverse order.

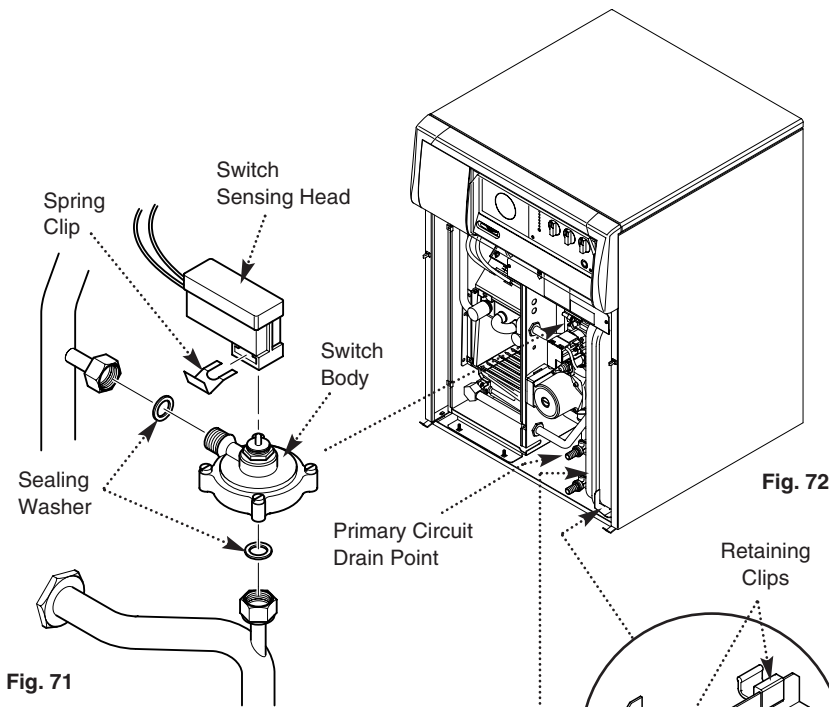

Fig. 71

11.16 Expansion Vessel (Figs. 72, 73 & 74)

1. Isolate the central heating system and drain the boiler primary circuit.
2. Remove the screws securing the wiring cover panel and disconnect the earth lead from the spade terminal on the rear of the panel.
3. Undo the nut at the top of the expansion vessel. Tilt the vessel forwards slightly and disengage it from the retaining clips on the boiler base plate.
4. Examine the sealing washer between the vessel and primary pipe, replacing if necessary.
5. Fit the new vessel, locating the lower flange in the retaining clips on the boiler base plate.
6. Reassemble in reverse order and repressurise the system.

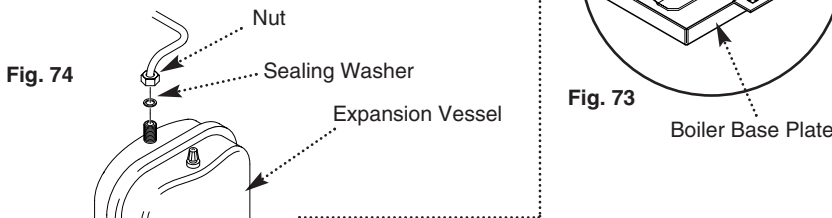

Fig. 74

Fig. 73

Boiler Base Plate

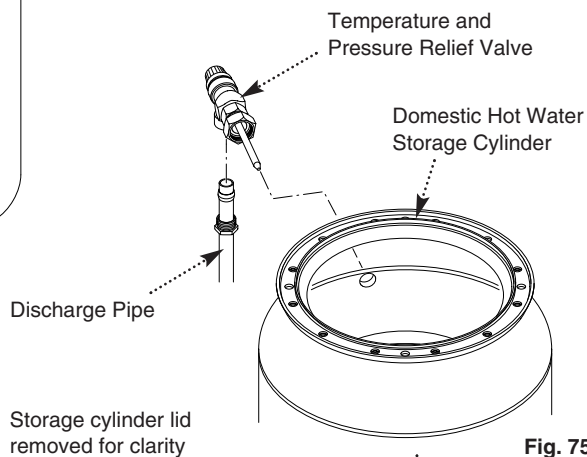

Fig. 75

11.17 Storage Cylinder Temperature & Pressure Relief Valve (Figs. 75 & 76)

1. Turn off the mains water supply and draw off any residual from the domestic hot water system. Drain the domestic hot water storage cylinder.
2. Undo the nut connecting the discharge pipe to the valve and ease the pipe away.
3. Undo the nut on the temperature and pressure relief valve securing it to the spigot on the storage cylinder and remove the valve.
4. Examine the sealing washer between the valve and cylinder, replacing if necessary.
5. Reassemble in reverse order.

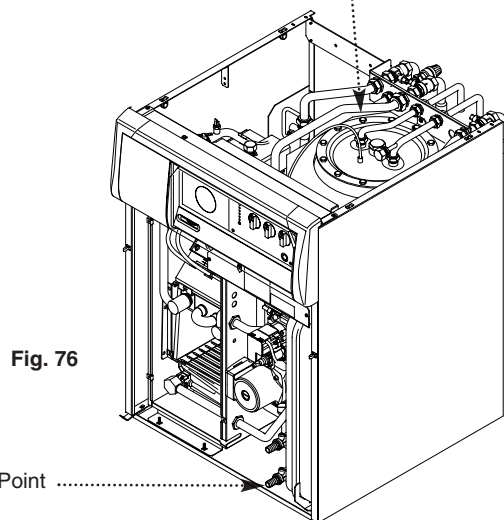

Fig. 76

Domestic Hot Water Storage Cylinder Drain Point

11.0 Changing Components

11.18 Pump - Head Only (Figs. 77, 78 & 79).

1. Isolate the central heating system and drain the boiler primary circuit. Remove the socket head screws securing the pump head to the body and draw the head away.

2. Undo the screw on the pump wiring cover and remove the cover. Using a suitable flat bladed screwdriver press the cable securing levers downwards to release each wire after noting their position.

3. A standard Grundfos 15-60 replacement head can now be fitted. Connect the wiring to the new head. **The pump speed must be set to 3.**

4. Reassemble in reverse order and repressurise the system.

11.19 Pump - Complete (Figs. 78 & 80).

1. Isolate the central heating system and drain the boiler primary circuit. Unscrew the automatic air vent from the pump body. Undo the union nuts on the inlet and outlet connections and draw the pump forwards.

2. Undo the screw on the pump wiring cover and remove the cover. Using a suitable flat bladed screwdriver press the cable securing levers downwards to release each wire after noting their position.

3. Connect the wiring to the new head and **set the pump speed to 3**. Using new sealing washers fit the new pump, fit the air vent to the pump body and reassemble in reverse order. Repressurise the system.

11.20 Automatic Air Vent (Figs. 78 & 80)

1. Isolate the central heating system and drain the boiler primary circuit.

2. Undo the screws securing the combustion box front panel. Remove the panel.

3. Using a suitable hexagon key, slacken the grub screw securing the return pipe boss to the heat exchanger. Undo the nut connecting the return pipe to the pump outlet pipe. Swing the return pipe to the left.

4. Remove the locknut securing the pump outlet pipe to the combustion box side panel. Undo the nuts at the pump outlet and differential pressure switch. Remove the pipe.

5. Unscrew the automatic air vent from the pump body. Examine the 'O' ring seal, replacing if necessary, and fit it to the new automatic air vent.

6. Reassemble in reverse order and repressurise the system.

Fig. 77

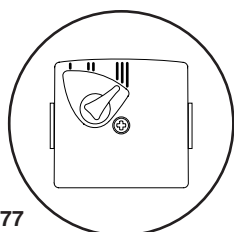

Pump Setting

Fig. 78

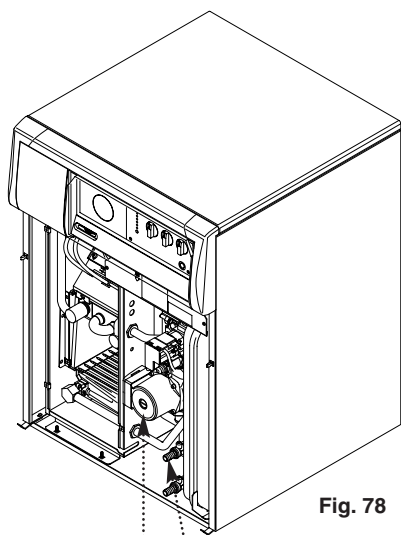

Primary Circuit
Drain Point

Fig. 79

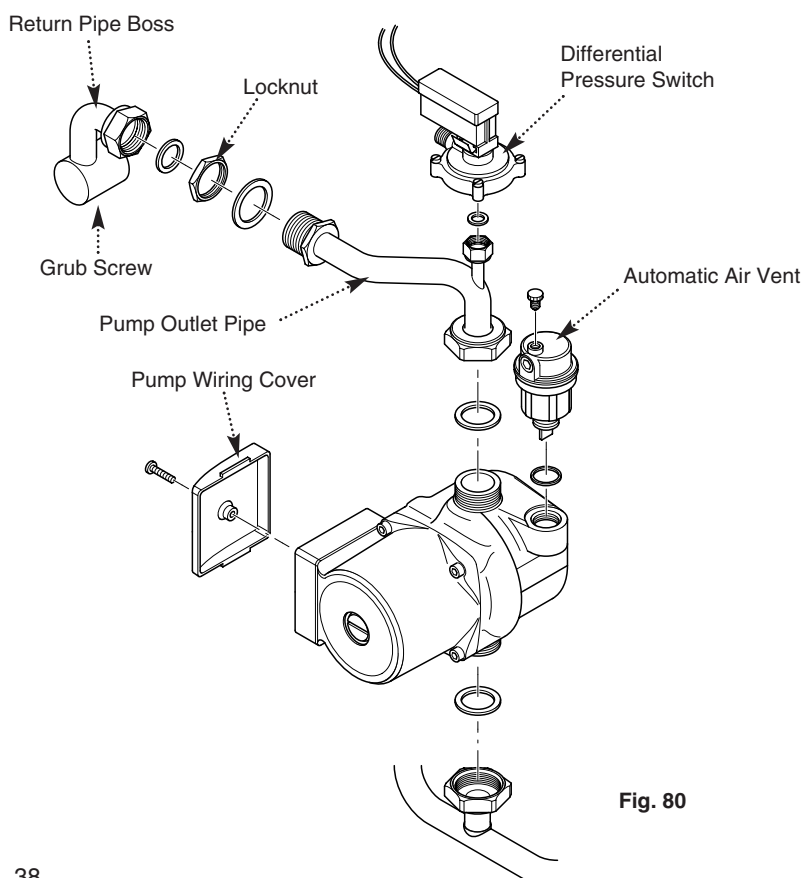
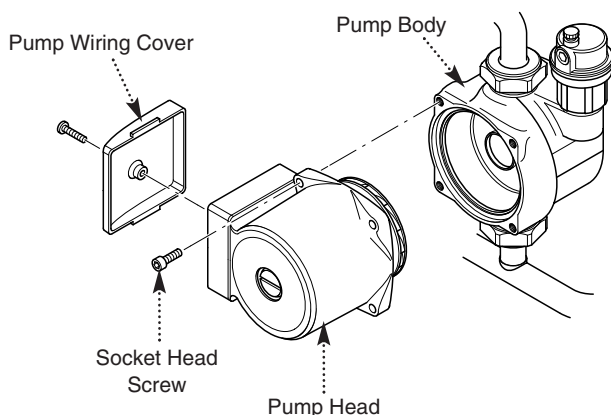

Fig. 80

11.0 Changing Components

11.21 Pressure Reducing Valve Cartridge (Figs. 81 & 82)

1. Turn off the mains water supply and draw off any residual from the domestic hot water system. Drain the domestic hot water storage cylinder.
2. Unscrew the cartridge from the the valve body and discard.
3. Reassemble in reverse order.

Domestic Hot Water
Storage Tank Drain Point

Fig. 81

11.22 Expansion Relief Valve Cartridge (Figs. 81 & 83)

1. Turn off the mains water supply and drain down the domestic hot water storage cylinder.
2. Unscrew the cartridge from the the valve body and discard.
3. Reassemble in reverse order.

Reducing Valve Cartridge

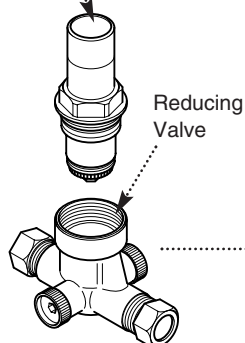

Fig. 82

Expansion Relief Valve Cartridge

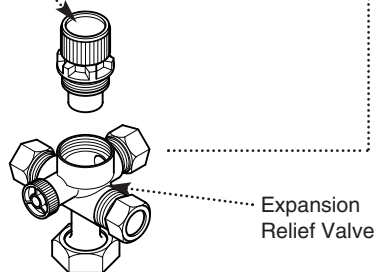
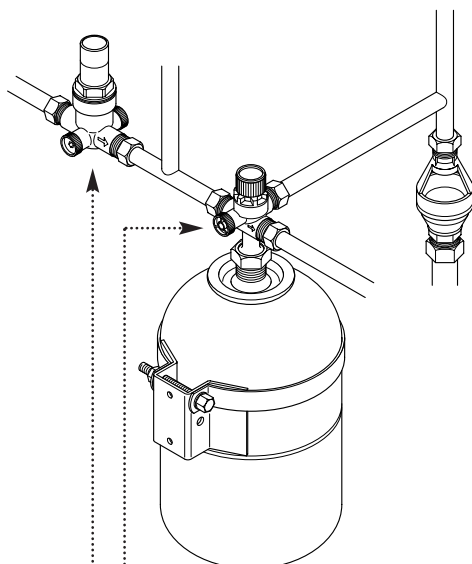
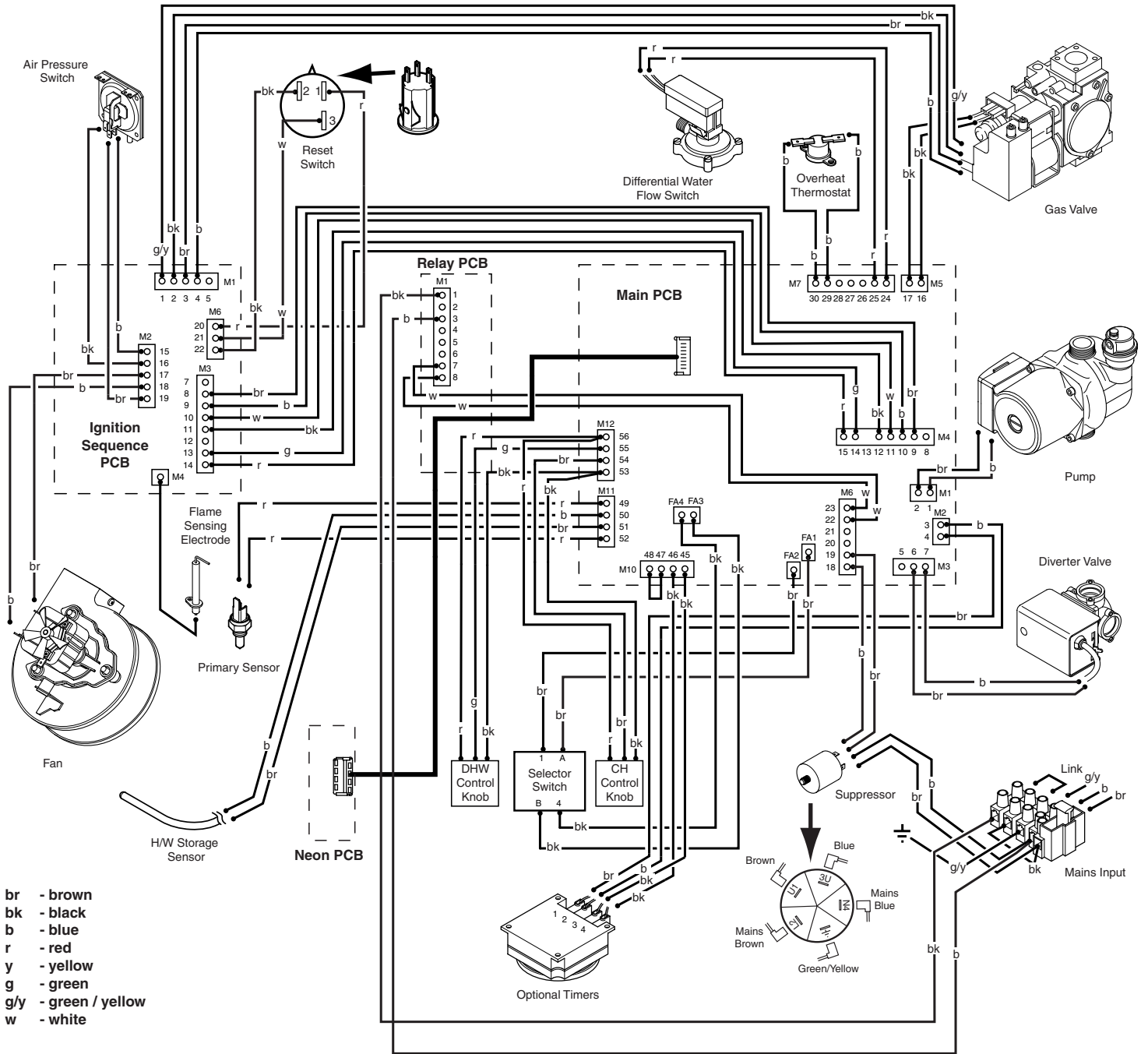

Fig. 83



12.0 Illustrated Wiring Diagram



13.0 Fault Finding

Refer to Section 12.0 "Illustrated Wiring Diagram" for position of numbered terminals

Central Heating - Follow operational sequence

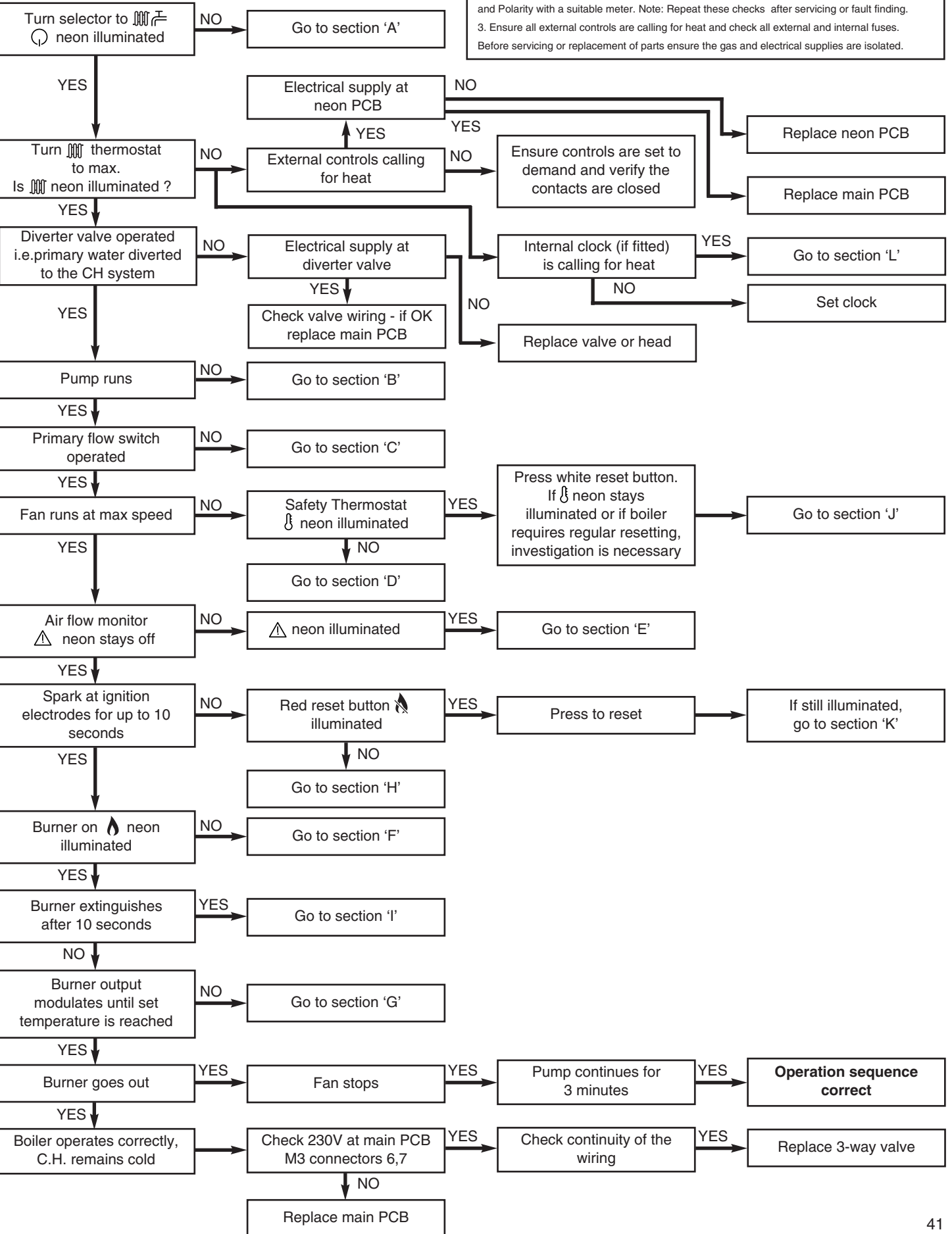

CARRY OUT INITIAL FAULT FINDING CHECKS

1. Check that gas, water and electrical supplies are available at the boiler. Electrical supply = 230V ~ 50 Hz. CH water system pressurised to 0.5 bar when the boiler is cold. The preferred minimum gas pressure is 19.5mbar (natural gas), 27mbar (butane) or 36mbar (propane).
2. Carry out electrical system checks, i.e. Ground Continuity, Resistance to Ground, Short Circuit and Polarity with a suitable meter. Note: Repeat these checks after servicing or fault finding.
3. Ensure all external controls are calling for heat and check all external and internal fuses. Before servicing or replacement of parts ensure the gas and electrical supplies are isolated.

Domestic Hot Water - Follow operational sequence (DHW storage at ambient temperature i.e. cold)

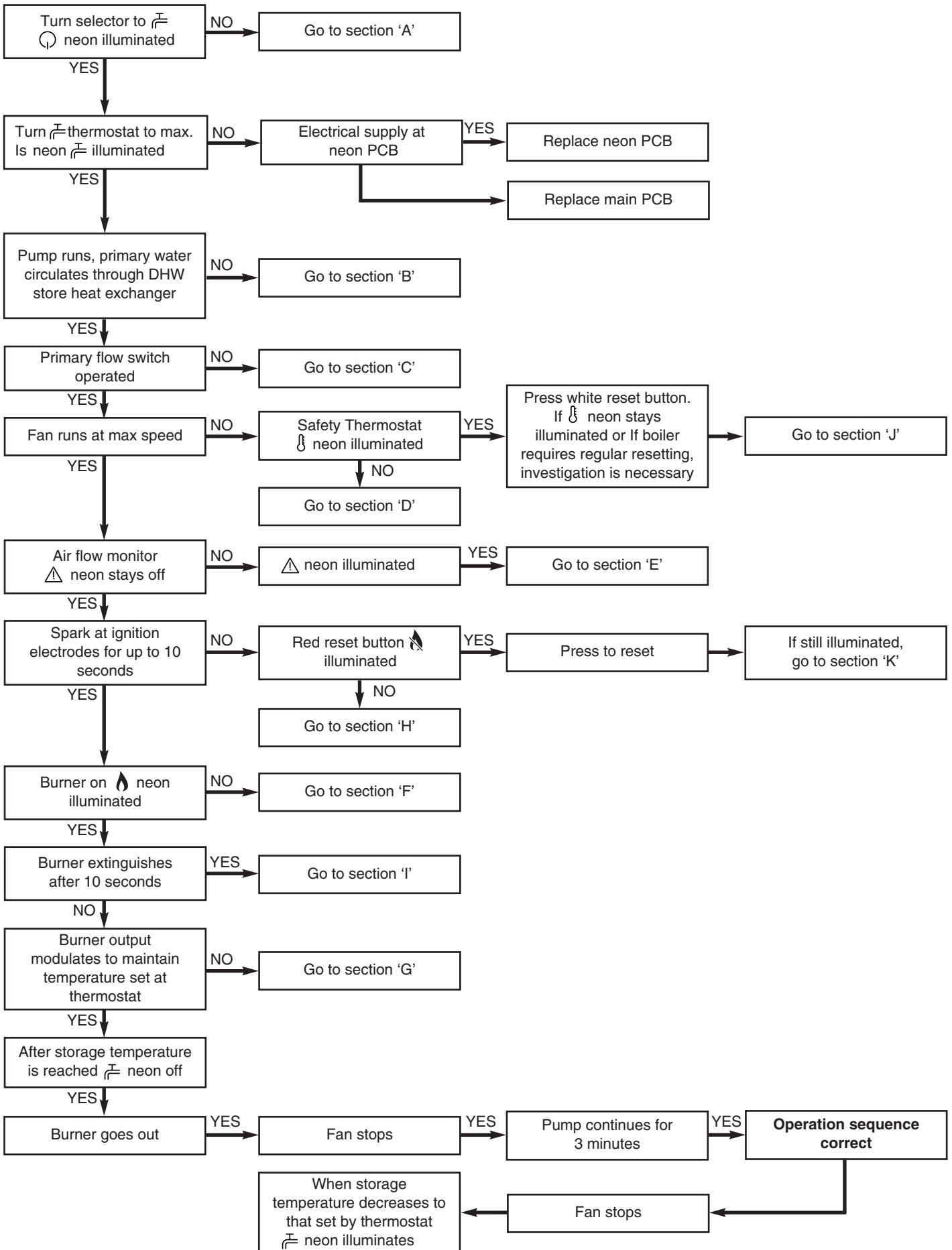

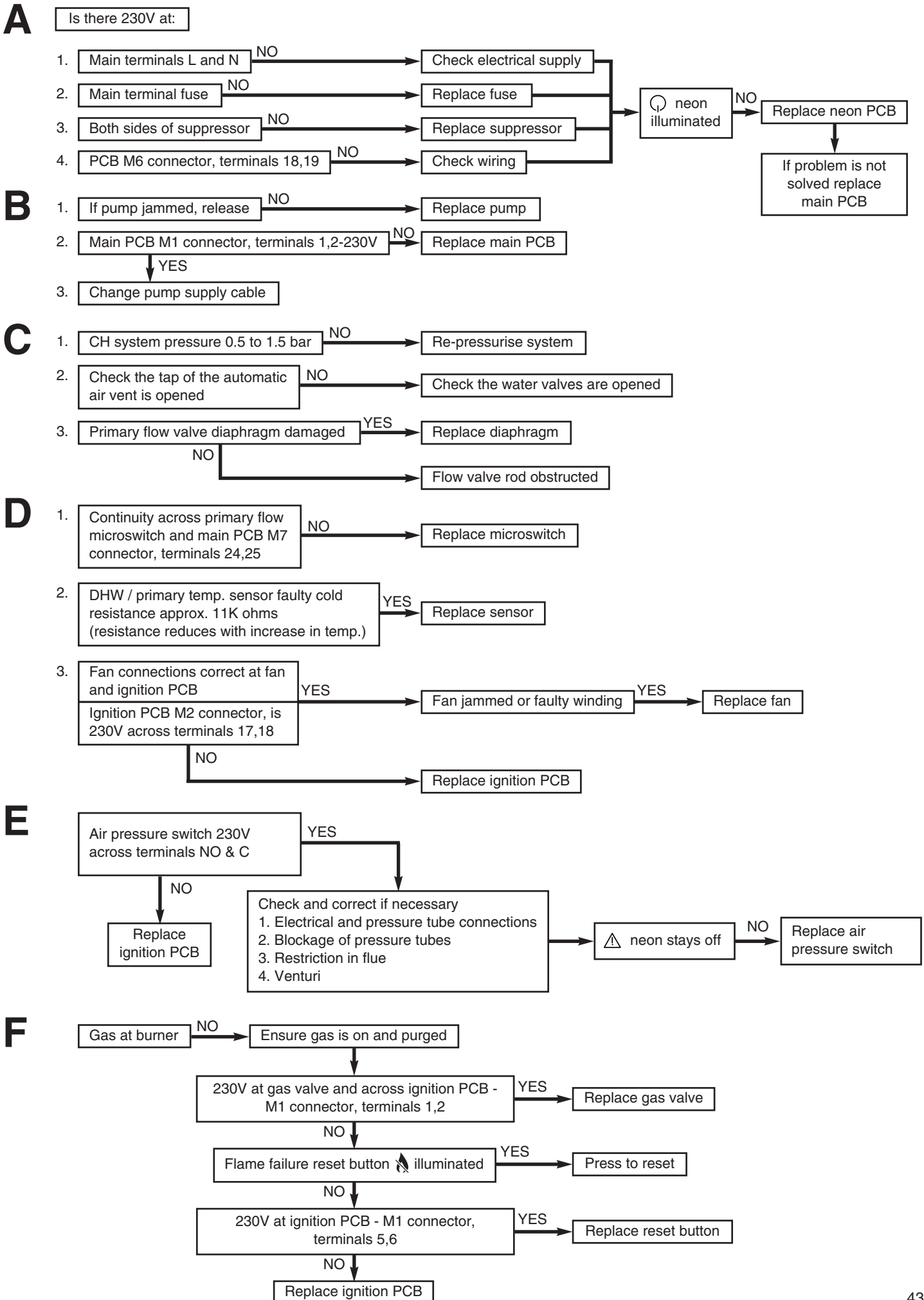

13.0 Fault Finding

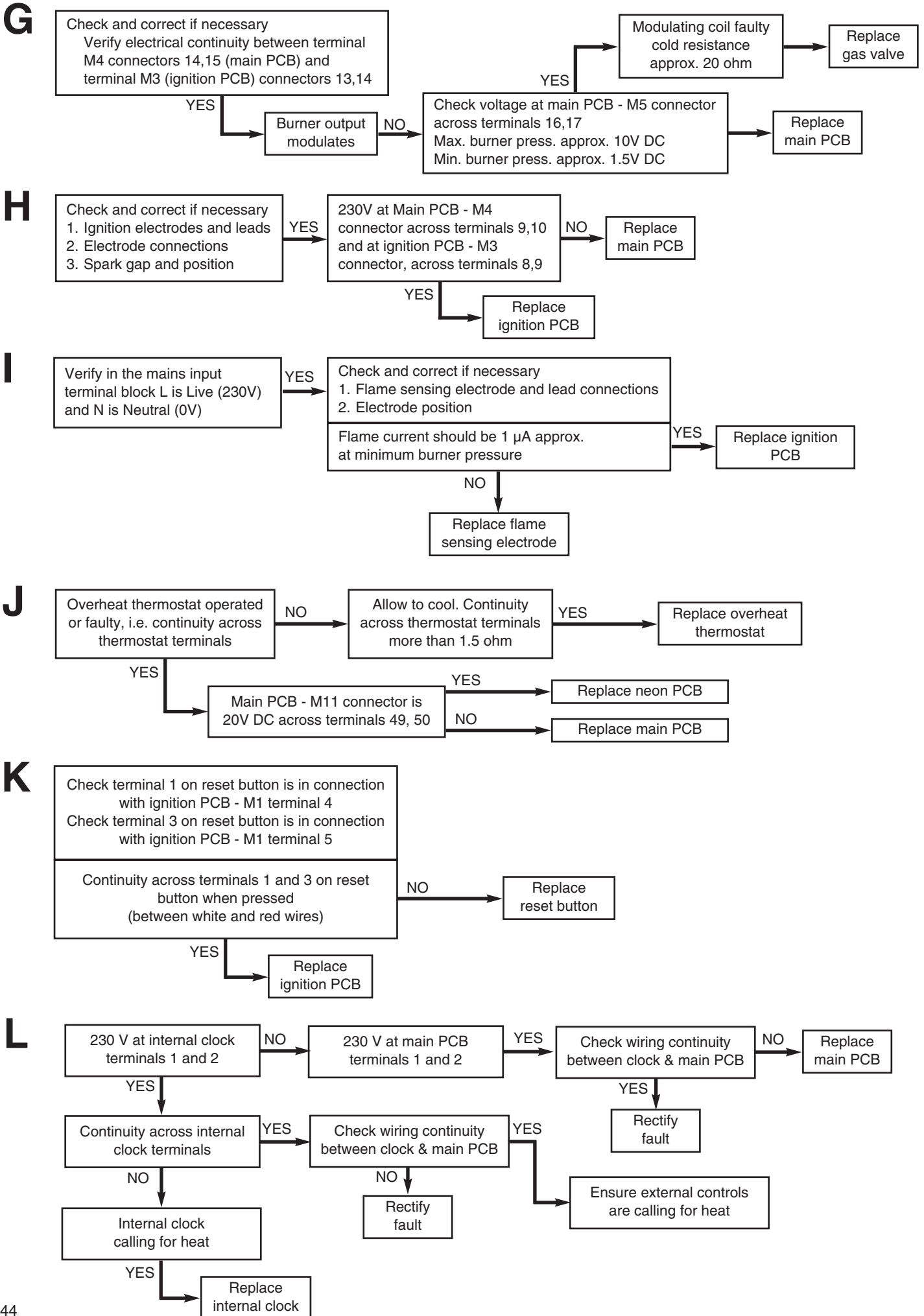

14.0 Short Parts List

Short Parts List

| Key No. | G.C. No. | Description | Manufacturers Part No. |
|---------|----------|------------------------------------|------------------------|
| 23 | | Pressure Switch | 248630 |
| 22 | 378-864 | Fan | 247381 |
| 41 | | Burner | 248636 |
| 310 | E03-572 | Pressure Differential Switch | 247388 |
| 72 | 379-799 | Pump | 247738 |
| 73 | | Automatic Air Vent | 248461 |
| 140 | E59-897 | Gas Valve | 247392 |
| 102 | | Diverter Valve (3 Port Valve) | 248653 |
| 169 | | Pressure Gauge | 248670 |
| 92 | | Safety Valve 3bar | 248650 |
| 274 | E59-948 | Cartridge Pressure Reducing Valve | 247403 |
| 275 | E60-000 | Cartridge Expansion Relief Valve | 247404 |
| 79 | E59-881 | Storage Temp/Pressure Relief Valve | 247405 |
| 32 | | Heat Exchanger | 248633 |
| 35 | | Expansion Vessel | 248634 |
| 44 | E03-569 | Burner Injector 1.18mm NG | 247439 |

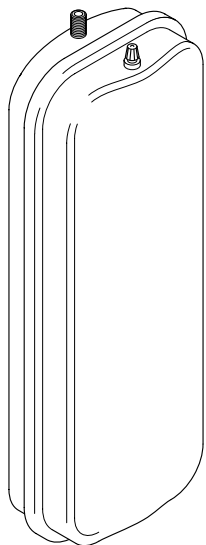

35

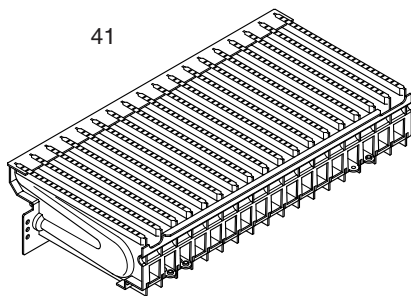

41

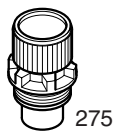

275

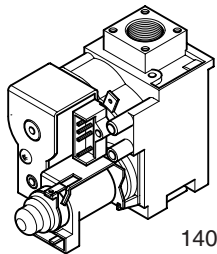

140

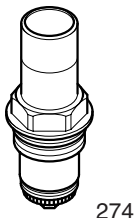

274

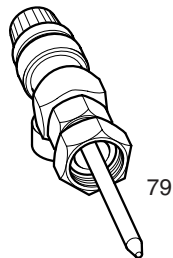

79

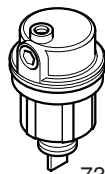

73

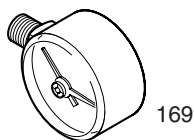

169

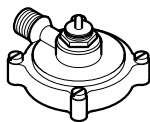

310

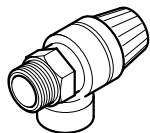

92



44

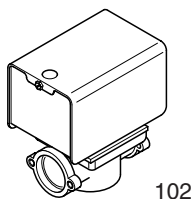

102

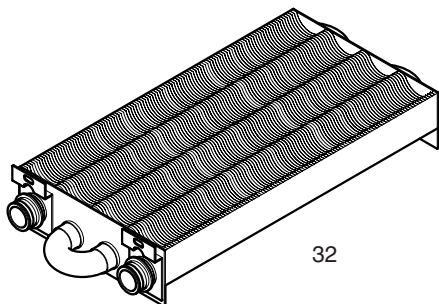

32

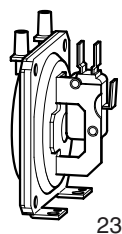

23

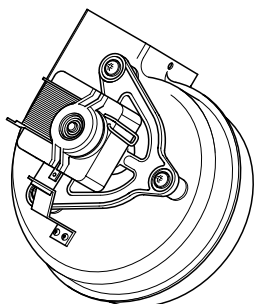

22

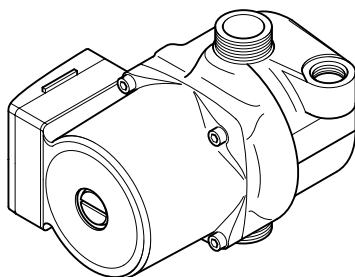

72

14.0 Short Parts List

Short Parts List

| Key No. | G.C. No. | Description | Manufacturers Part No. |
|---------|----------|----------------------------|------------------------|
| 65 | E59-875 | Electrode Ignition/Sensing | 247382 |
| 59 | E03-582 | Electrode Lead Ignition | 247385 |
| 314 | | Electrode Lead Sensing | 248710 |
| 342 | E60-098 | Microswitch Loom | 247453 |
| 135 | | Limit Thermostat (O/Heat) | 248656 |
| 131 | | Temperature Sensor | 248655 |
| 172 | 379-764 | Suppresor | 247397 |
| 154 | | Main PCB | 248672 |
| 155 | | Ignition PCB | 248673 |
| 156 | E59-912 | Neon PCB | 247400 |
| 171 | 343-718 | Relay PCB | 247401 |
| 315 | | Storage Cylinder Sensor | 248711 |

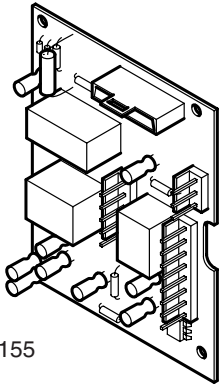

155

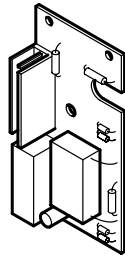

171

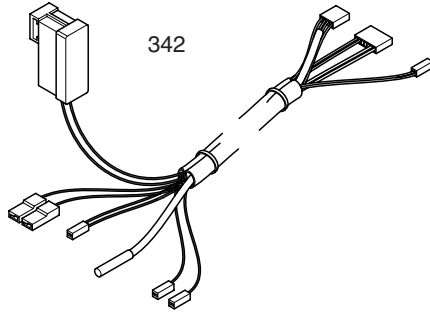

342



59



314

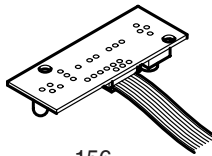

156



135

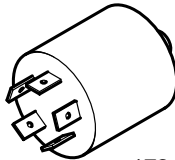

172



131

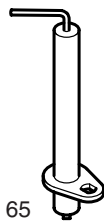

65

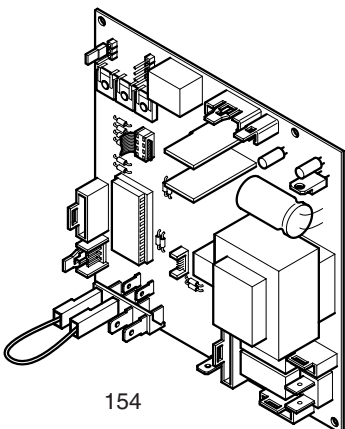

154

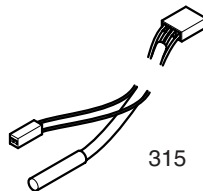

315

Baxi UK Limited manufacture a comprehensive range of products for the domestic heating market.

**Gas Central Heating Boilers
(Wall, Floor and Fireside models).**

Independent Gas Fires.

Renewal Firefronts.

Gas Wall Heaters.

Solid Fuel Fires.

If you require information on any of these products, please write, telephone or fax to the Sales Department.

After Sales Service
08706 096 096

Technical Enquiries
08706 049 049

BAXI

Baxi UK Limited
Brownedge Road
Bamber Bridge Preston
Lancashire
PR5 6SN
www.baxi.com