

Wonderfire

AIRFLAME EXCEL MK.3 *remote control*

AF 16NV RC	9500370
AC 16NV RC	9500371
AF 16XL RC	9500372
AC 16XL RC	9500373

INSTALLATION & SERVICING MANUAL

Patent applied for

Please leave these Instructions with the user

This Appliance is for use in the United Kingdom (GB) and the Republic of Ireland (IE) only.

9860377/02

IMPORTANT NOTES

If your Wonderfire Airflame Excel Mk.3 burner is to be installed within a mk.3 Wonderfire convector box, then this manual should be read in conjunction with the convector box installation manual (part number 9860371). This appliance is intended for decorative purposes. Under no circumstances must rubbish or debris of any description be thrown onto the fuel bed.

Please read the following section before commencing with installation.

Before installation, ensure that the local distribution conditions (identification of the type of gas and pressure) and the adjustment of the appliance are compatible.

It is the law that competent persons, in accordance with the Gas Safety (Installation and Use) (amendment) Regulations 1994, install all gas appliances.

Improper installation of this decorative open gas fire could be hazardous to health. This fire is to be used only in a properly flued, incombustible, masonry fireplace with the chimney or flue free of any obstruction or damper. If in doubt consult building regulations or a supplier.

This appliance must be installed in accordance with the rules in force.
The flue must be swept before installation.

This appliance must be fitted in a fireplace opening conforming to BS 1251.

A flue with a minimum diameter of 7", a minimum effective height of 3 metres, with a good upward draught is required for fires operating within standard fireplace openings. Larger fireplace openings may require a correspondingly larger chimney diameter, a faulty flue or chimney may result in products of combustion spilling into the room with consequent possible damage to furniture and decor. Conduct a smoke test before proceeding with installation. If the burner is being installed within a Wonderfire convection box please see separate instructions.

GB only: (XL models only). A permanent ventilation grille of fixed design and having a minimum free area of 100cm² must be fitted with direct access to outside air to room.

Note: see convector instructions if being installed within a Wonderfire convector box for ventilation requirements.

IE only: This appliance must be installed in accordance with IS 813 1996 (as amended).

We strongly recommend the use of an approved fireguard whenever the elderly, infirm or young children are in the presence of a working fire.

The appliance is fitted with an A.S.D. (atmosphere sensing device) if the appliance closes down after a period of operation for no apparent reason, the consumer should be informed to stop using the appliance, until the installation and appliance have been thoroughly checked.

BATTERY REQUIREMENTS:

HANDSET :	1 x 9V	(PP3 type)
RECIEVER:	4 x 1.5V	(AA type)

RELATED DOCUMENTS:

Gas Safety (Installation and Use) Regulations 1994 (as amended)	BS 5440 Part 1 1990
BS 5871 Pt 3 Installation of Decorative Fuel Effect Fires	BS 5440 Part 2 1989
Fireplace components conforming to BS 1251 assembled in accordance With BS 8303-1986	BS 5871 Part 3 1990
Relevant Building Regulations	BS 6461 Part 1 1984
Republic of Ireland: IS 813 1996 (as amended)	BS 6461 Part 2 1984

CONTENTS

Check contents before proceeding with the installation of your Wonderfire

1. 1 x Burner Assembly
2. 1 x Two-piece front Coal
3. 1 x Ceramic Fuel Matrix
4. 1 x Set of Dress Coals
5. 1 x User instructions
6. 1 x Installation Instructions
7. 1 x Guarantee card
8. 1 x Loose parts pack (containing 1 x fixing screw and 1 x fibre rawlplug)
9. 1 x Smoke match tube
10. 1 x Remote control handset
11. 1 x PP3 battery
12. 4 x AA batteries

TECHNICAL DATA

Heat inputs (gross):

	AF16NV RC	AF16XL RC	AF16NVP RC **
Minimum	3.1kW	3.1kW	4.7kW
Maximum	6.95kW	10kW	6.2kW

Setting pressures:

	AF16NV RC	AF16XL RC	AF16NVP RC **
Maximum (cold)	17.5mbar ± 0.75 mbar	14.5mbar ± 0.75 mbar	36.0mbar ± 0.75 mbar

Injector sizes:

AF16NV RC	AF16XL RC	AF16NVP RC **
82-442	82-702	92-200

Supply pressures:

Natural gas (G20)	20mbar
Propane (G31)	37mbar

Burner tray dimensions:

Width	375mm (15") at front tapering to 280mm(11¼") at rear
Depth	225mm (9")
Height (including dress coals)	295mm (11½")

** When converted using kit number 9500376

INSTALLATION AND COMMISSIONING INSTRUCTIONS

PLEASE READ CAREFULLY BEFORE STARTING WORK

Fireplace, flue and ventilation details

Read the important notes on the inside front cover before proceeding with the installation of your fire. Only when you have complied with all of the above should you commence with the installation of the appliance.

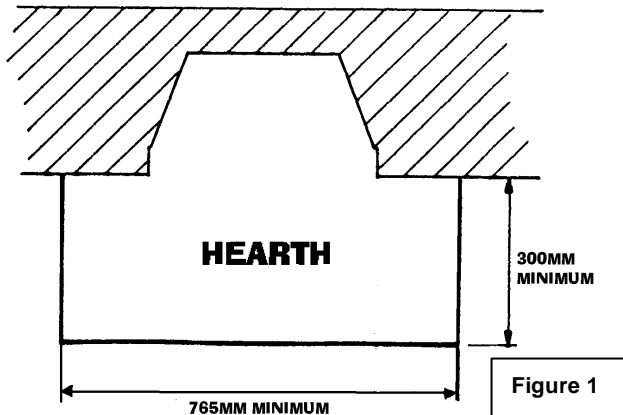

NOTE: Hearth requirements in Figure 1. The appliance must be mounted behind a non-combustible hearth (N.B. conglomerate marble hearths are considered as non-combustible). The appliance can be fitted to a purpose made proprietary class “O”-150°C surround. The hearth material must be at least 12mm thick. The periphery of the hearth (or fender) should be at least 50mm above floor level to discourage the placing of carpets or rugs over it. The surface of the hearth must be sufficiently flat to enable the bottom of the front surround and the bottom front cover to be aligned horizontally. Any excessive unevenness (uneven tiles, Cotswold stone, etc.) should be rectified. The appliance must not stand on combustible materials or carpets.

The minimum height from the top surface of the hearth to the underside of any shelf made from wood or other combustible materials is as follows:-

- For a shelf up to 150mm deep:
Minimum height = 818mm.
- For a shelf deeper than 150mm: 818mm + 12.5mm for every 25mm depth over 150mm.

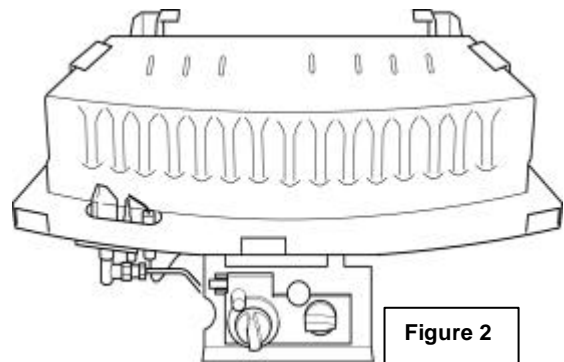

Burner Position

The burner (figure 2) is produced from a soft ceramic material and should be handled carefully.

Remove all packaging material from the burner, and inspect for any signs of mishandling which may affect the performance. There are two sets of burner ports. One set are located on the top face of the burner, and the other, on the front face. Each unit is flame tested before it leaves the factory, and as a result, some slight discoloration may be evident around the burner ports. There may also be some slight surface cracking evident on the burner, which is completely normal and is not detrimental to performance. The burner is retained by two clamps and set in position before it leaves the factory. Check that the injector is aligned straight and central to the venturi. Check that the pilot unit is clear of the front face of the burner by 2-4mm.

8mm (5/16) Bundy or semi-rigid tubing must be used to connect the appliance to the gas supply.

Centre the burner tray in the fireplace opening with the tray as far to the rear as possible. Secure the burner in position and fix through the centre front leg into the hearth using a heatproof wall plug and fixing screw (supplied). Purge the gas supply and make the connection to the control. Test all joints for gas soundness.

Attach a manometer to the pressure test point (see figure 2a) and follow the lighting procedure to establish the pilot and then turn to maximum setting. Check the gas pressure against the setting pressures (see gas data).

Turn off the fire and allow to cool.

COMMISSIONING THE BURNER

Placing the front coal

Remove the front coal from its protective packaging and position in front of the burner as shown in figure 3. The front coal should fit snugly between the burner and the two raised tabs on the front edge of the tray.

Placing the fuel matrix

Remove the fuel matrix from its protective packaging and position on top of the burner as shown in figure 4. The rear face of the burner should locate into two cut-outs on the top face of the rear legs. Ensure that the matrix sits flatly on the top of the burner.

Placing the dress coals

Open the loose coals bag to find a further three bags. These contain:

- 2 x Finger coals
- 4 x Square
- 15 x Random cut coals

Open the bags and keep the different types of coals separate. Begin the coal build by placing a square coal in the centre of the front coal, ensuring that it bridges across to the matrix as shown in figure 5.

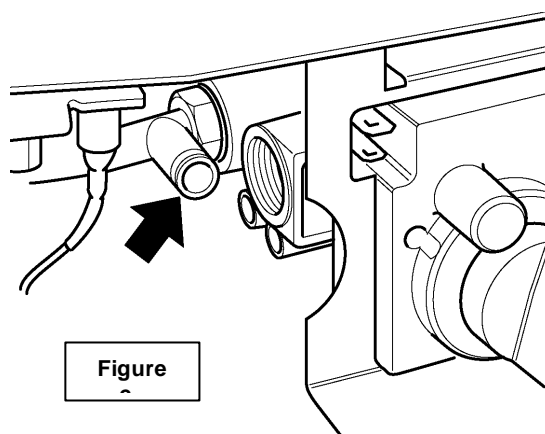

Figure

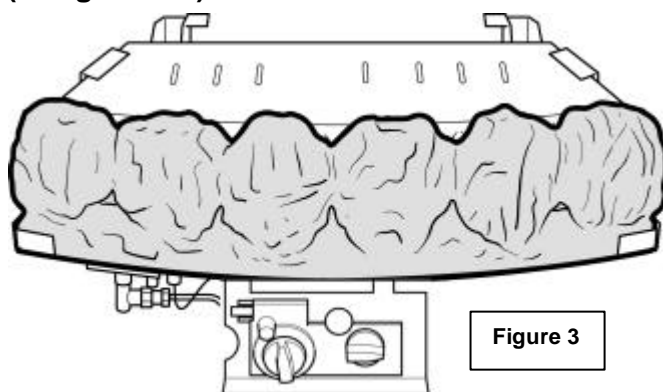

Figure 3

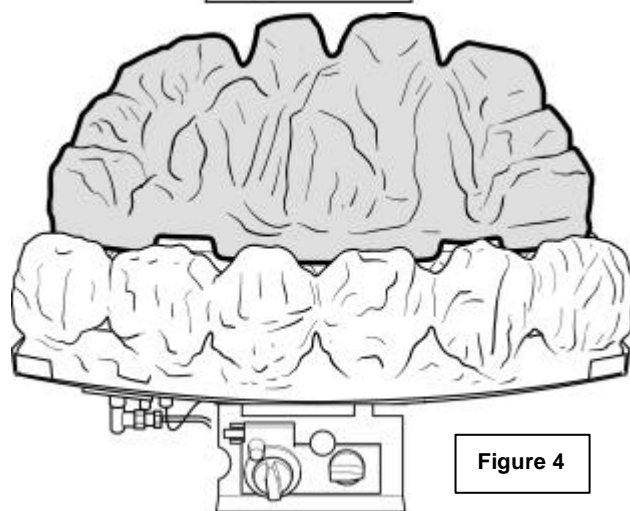

Figure 4

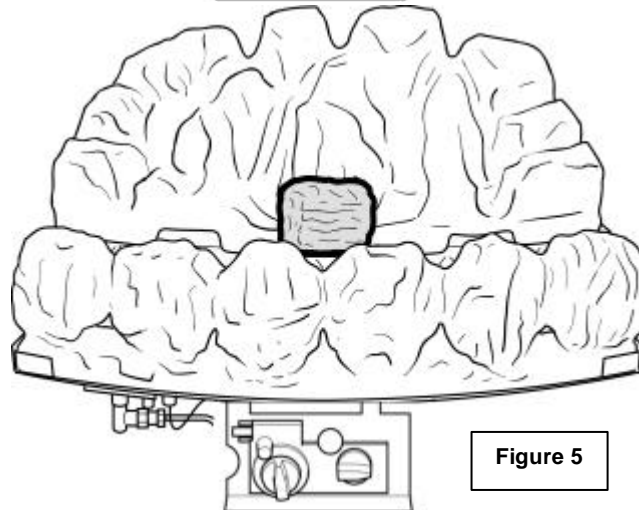

Figure 5

Next, take four random coals and place along the front coal as shown in figure 6. Again, ensure that these coals bridge across from the front coal to the matrix. In order to get the best flame effect, it is important that the coals are evenly spaced, and sit 10-15mm from each other.

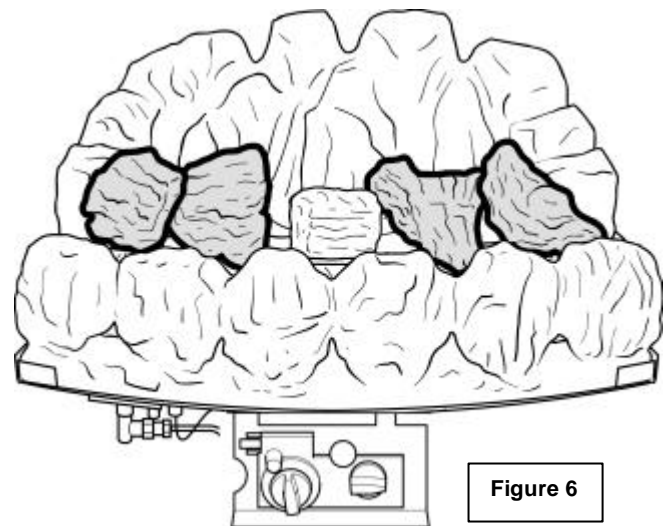

Figure 6

Next, take both finger coals and place one at each end of the front row of coals as shown in figure 7, again making sure that they bridge across from the front coal to the matrix.

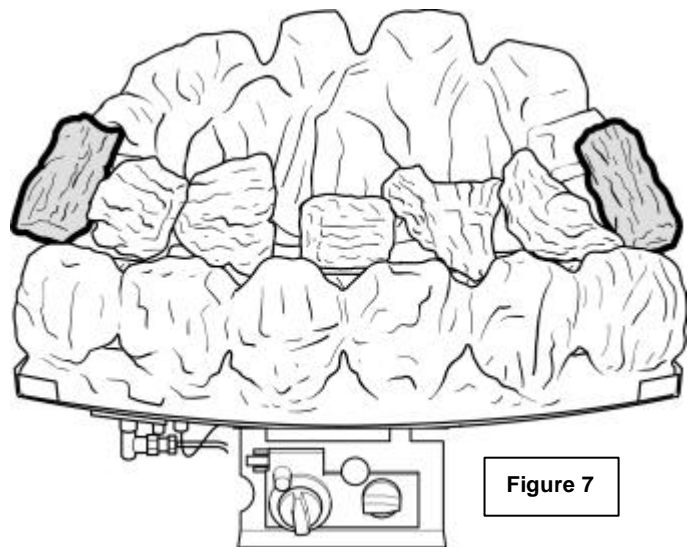

Figure 7

Now take six random shaped coals and position as shown in figure 8. This second row of coals should rest on top of the first row, overlapping by 5-10mm. Again, ensure even spacing to obtain the best flame effect.

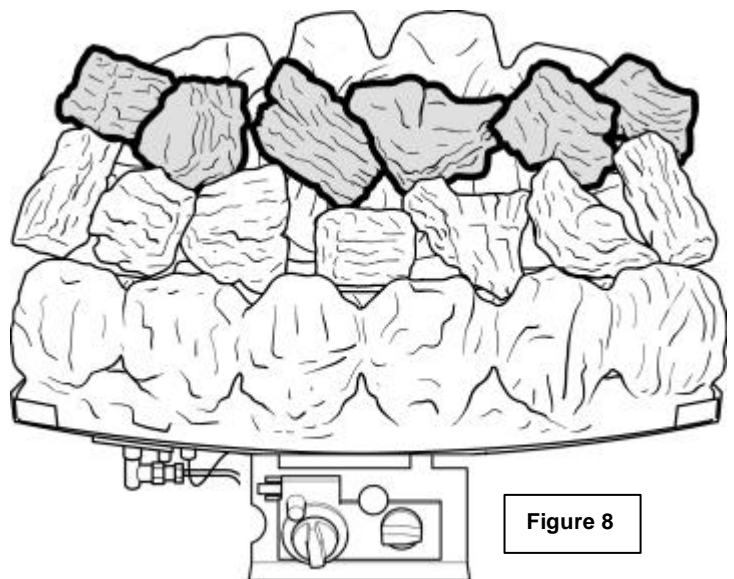
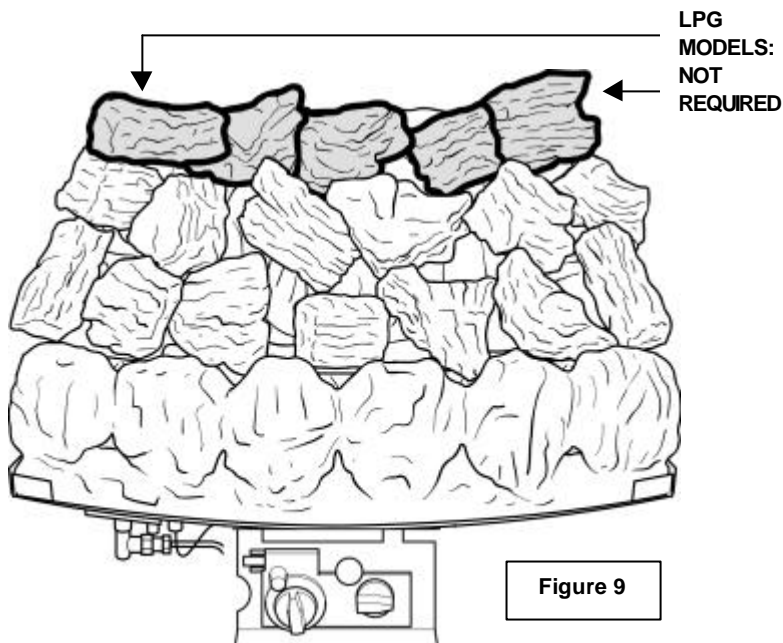

Figure 8

Placing the dress coals – continued

NG MODELS ONLY: Next, take five random shaped coals and arrange as shown in figure 9. Again, these coals should overlap the previous row by 5-10mm. Once again ensure even spacing.

LPG MODELS ONLY: Take three random coals and position in the centre of the matrix, spaced 10-15mm from each other to make the third row. Discard the two remaining random coals.



Finally, take the three remaining square coals and position at the back of the matrix as shown in figure 9a. These coals should also overlap the previous row by 5-10mm and also, even spacing is once again important.

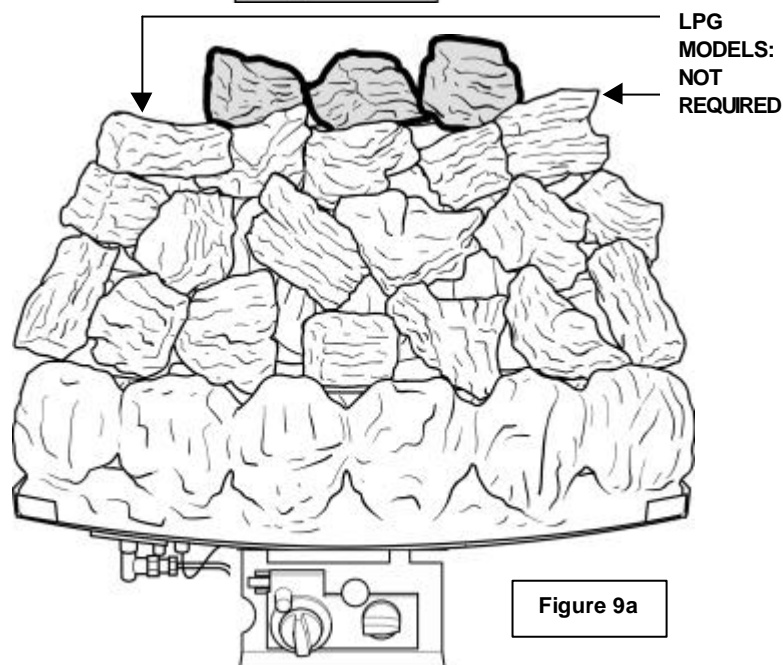

OPERATION OF THE FIRE

This fire may be controlled manually, by use of a gas valve mounted on the appliance. The flame settings may also be controlled by means of the remote control handset.

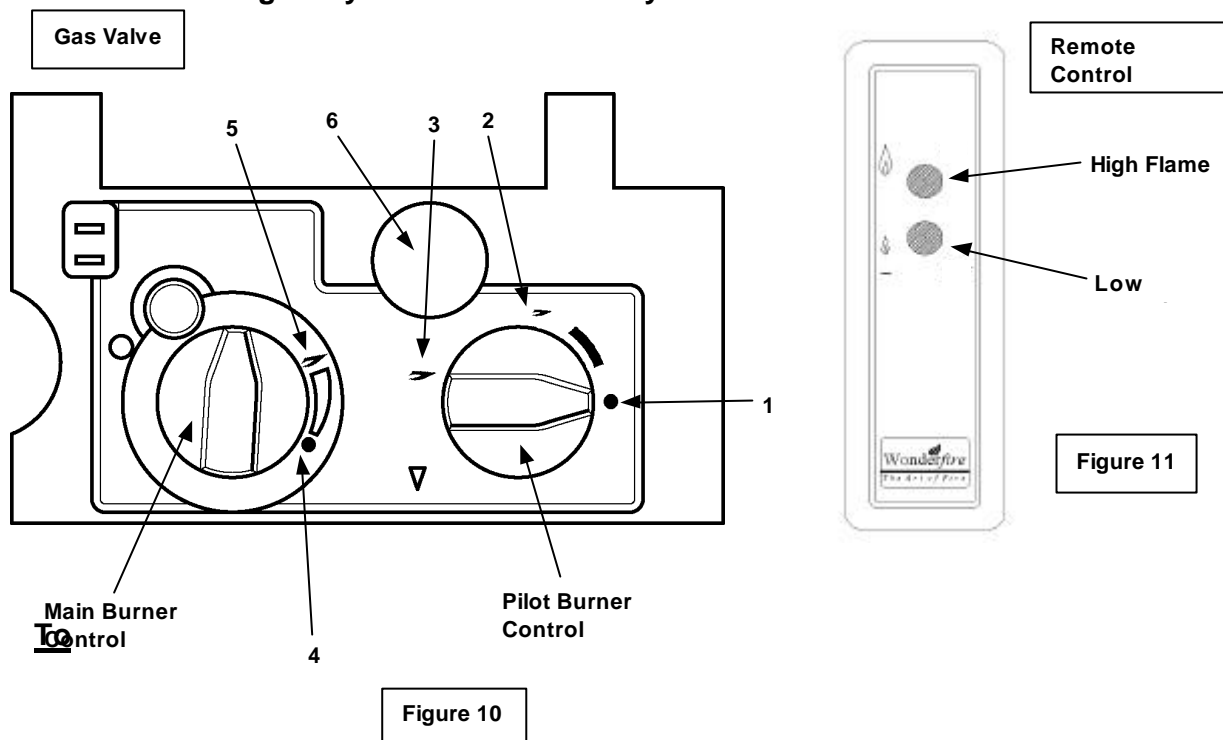

To prevent accidental operation of the fire, we recommend that the fire be switched off when not in use.

Light the Pilot

Please note:- The fire must be lit manually.

Ensure that the pilot burner control knob is in the OFF position (1). Depress the control knob and turn anti-clockwise to the ignition position (2) to activate the piezo ignition system. A 'click' will be observed, and the pilot should light. Hold the knob in

This position (keeping it depressed) for ten seconds to allow the flame supervision device to establish.

Observe if it is alight by looking through the slots to the left hand end of the front coals.

If the pilot does not light immediately, repeat the above procedure, keeping the knob depressed for several seconds in order to purge any air from the system.

If after ten seconds, ignition has not occurred, turn the control knob back to the OFF position and repeat the ignition procedure after 30 seconds.

Once the pilot is lit, keep the control knob depressed for ten seconds to allow the flame supervision device to establish.

Operation of the fire – continued

When the control knob is released, the pilot should remain lit. If the pilot fails to remain lit, repeat the ignition procedure, this time keeping the control knob depressed for a longer period of time.

Lighting the Main Burner

Once the pilot light is established, the main burner can be lit by turning the pilot burner control knob anti-clockwise to position 3 (refer to figure 10), and by then turning the main burner control knob to the 'high' position (5).

Controlling the heat setting.

In order to change from one setting to another turn the main burner control knob to the required position. Alternatively, if a setting between LOW (4) and HIGH (5) is required, then the control knob may be turned to this position.

Note: We recommend you use the appliance at a low setting for the first few hours of use to reduce the thermal cracking of the surface of the burner.

Surface cracking of the burner is normal and is no cause for concern. Whilst binding materials are being burnt out of the burner there may be a slight odour.

To Turn the Fire back to Pilot Setting

Turn the main burner control knob fully clockwise. Alternatively turn the pilot burner control knob clockwise to the ignition position (2). Refer to figure 10.

To Turn the Fire off

Rotate the pilot/burner control knob clockwise to position 1, as shown in figure 3.

Using the Remote Control Handset

When the pilot burner control knob is in position 3, the remote control handset may be used to vary the flame effect between 'High' and 'Low', or switch the fire back to pilot setting.

The handset operates on ultrasonic principles, and as such it is not necessary to point the handset directly at the fire.

In order to vary the flame effect between 'High' and 'Low' position, press, and keep depressed, either the 'High Flame' (or 'On') button, or the 'Low Flame' (or 'Off') button as appropriate. Refer to figure 11.

In order to switch the fire to pilot setting, depress the 'Low Flame' (or 'Off') button, and hold until only the pilot flame remains alight.

In order to disable the handset, but still leave the pilot alight, turn the pilot burner control knob to the ignition position 2. Refer to figure 10.

Battery Life & Replacement

Please note: In order to ensure maximum battery life and optimal performance, we recommend that only 'Long Life' type replacement batteries are used.

Handset

The remote control handset is powered by 1 x PP3 battery, which should be replaced approximately every 12 months.

To replace: Remove cover from rear of handset, remove and discard old battery. Replace battery and refit cover. See figure 12.

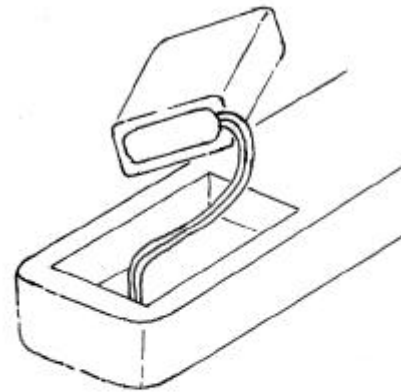
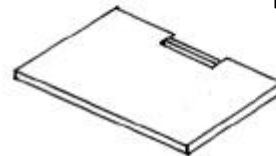

Figure 12



Receiver Unit

The receiver/valve is powered by 4xAA batteries, which should be replaced every 12 months.

To replace: Make sure the fire is switched off. Remove the front iron and ash-pan cover. Withdraw the battery holder as shown in figure 13, and open. Remove the old batteries and discard. Replace with new batteries. Refit batteries into holder and replace cover. Re-fit battery holder, also shown in figure 13.

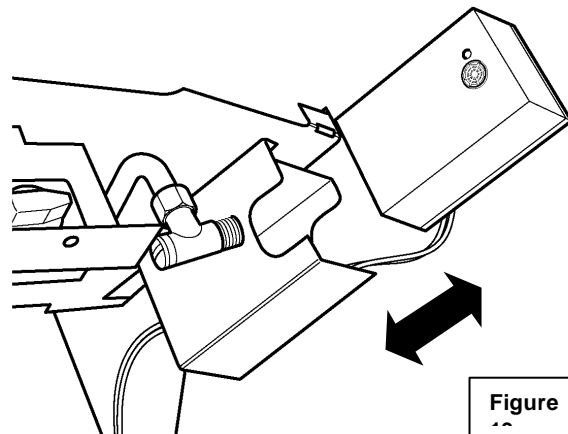
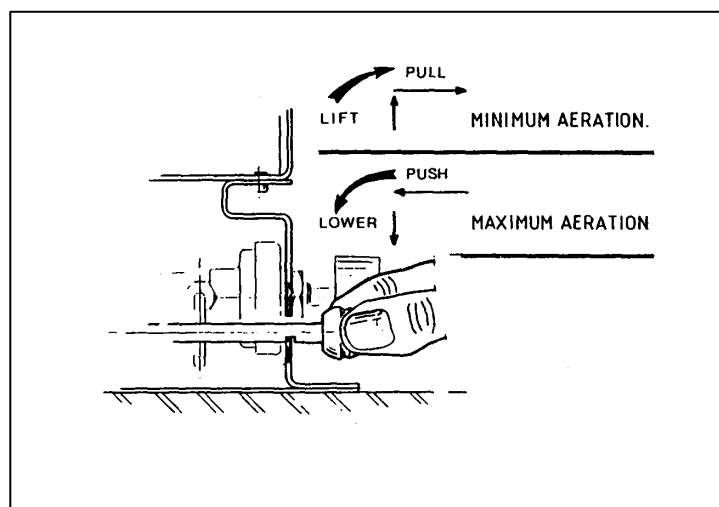

Figure 13

For fires fitted with Aeration Control

To operate the aeration control system, the following procedure should be followed:

- Allow the appliance to warm up, (for at least fifteen minutes) in the fully aerated position, with the control lever pushed in to the locked position – see figure 14, also see figure 10 item No. 6 aeration control knob.



- Switch to the minimum aerated position by slightly lifting the control lever. The spring mechanism will close the aeration shutter.
- To return to the fully aerated position.

Figure 14

Please note : It is advisable to run the fire in its fully aerated mode (control knob pushed in) at the beginning of each operation and if running at the minimum rate setting, or to burn off any carbon deposits which may have built up after prolonged use of the minimum aerated setting.

CLEARANCE TEST

Note : this test is to be conducted with the firefront in position. Warm up the appliance on MAX for ten minutes. Insert a smoke match tube as shown in figure 15, 30mm from either side of the fireplace opening, Smoke should be drawn positively into the appliance. If not repeat the test after a further fifteen minutes. If smoke is still not positively drawn into the appliance,

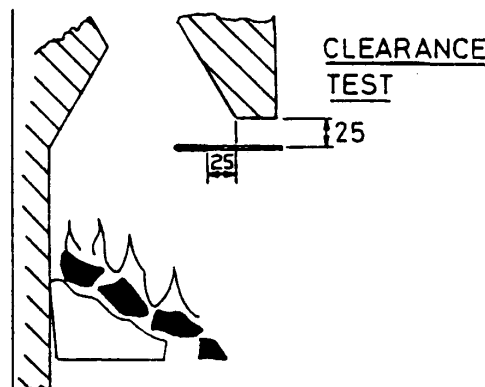

Figure 15

isolate the gas supply to the appliance position push the control lever in and slightly downwards until it rests in its locked and seek expert advice.

SERVICING AND MAINTENANCE

See convector instructions if your Airflame Excel mk.3 burner is installed within a Wonderfire convector box.

Annual Maintenance

The coals should be removed and any sooting carefully brushed from the surface with a soft brush.

The coal matrix should be removed and any debris shaken off. The burner should be removed from the fireplace and any debris carefully removed using a soft brush. Inspect the burner for any damage and repair or replace if necessary. Please note surface cracking of the burner is quite normal.

Check the venturi and injector for linting and clean if necessary. Clean any debris or carbon from around the pilot unit and check the correct operation of the gas control. Reinstall the burner into the fireplace, reconnect the gas supply and check the soundness of all gas connections. Refit the coals in accordance with the section of this manual entitled, "Commissioning the burner".

Follow the lighting procedure and check for spillage. If spillage is found the cause should be identified and remedied.

Check any purpose made room ventilation is free from obstruction.

NEVER ATTEMPT TO INSPECT OR REMOVE THE FIRE UNLESS IT HAS BEEN ALLOWED TO COOL FOR AT LEAST 15 MINUTES

The following procedures should be carried out with these tools at hand.

Slot head screwdriver	12mm spanner	3/4 AF spanner
7mm spanner	14mm spanner	External circlip pliers
10mm spanner	15mm spanner	Phillips No.2 type screwdriver
11mm spanner	16mm spanner	

Before servicing the component parts carry out the following procedure:

1. Turn off the appliance and wait least 15 minutes to allow the fire to cool.
2. Isolate the gas supply.
3. Remove the coals, matrix and front coal.
4. Disconnect the inlet supply/appliance union.
5. Unscrew the appliance fixing screw.
6. Remove the appliance.

To remove the injector:

Carefully invert the burner assembly ensuring that the ceramic surfaces are not damaged. Disconnect the injector/supply pipe union, place the burner assembly upright. Remove the injector. Replace in reverse order.

To remove the Piezo unit:

The piezo unit is an integral part of the gas valve, and cannot be removed. – refer to section entitled “To remove gas valve”.

To remove the thermocouple/pilot unit:

The thermocouple is an integral part of the pilot unit, and must be replaced as such. To remove the pilot unit, disconnect the pilot gas feed pipe at the union with the pilot elbow, disconnect the H.T. lead from the pilot unit. Disconnect the thermocouple from the gas valve. To detach the unit from the burner, first remove the screw securing the dust cage to the pilot/burner. Carefully remove the dust cage and place aside. Remove the second retaining screw and withdraw the pilot unit. Replace in reverse order.

To remove the gas valve/F.S.D.

Invert the burner assembly, disconnect the inlet pipe union, pilot supply union, manifold pipe union, H.T. lead, and thermocouple connecting nut from the valve end. Remove two retaining screws and withdraw the valve from the front leg. Replace in reverse order.

FAULT FINDING CHART

Problem	Remedy
Pilot light will not light when ignition button is pressed.	<ol style="list-style-type: none"> 1. Check that the lighting instructions are being followed. 2. Check that the spark is jumping between the electrode and the pilot head. If not, check for debris around the electrode, condition of the wiring and any possible short circuit. 3. Check that the gas is passing through the pilot injector. If not, check pipe, injector and tap for possible blockage and rectify. 4. Purge the system.
Pilot light ignites, but will not establish after holding the tap knob in for ten seconds.	<ol style="list-style-type: none"> 1. Ensure that the pilot flame is impinging on the thermocouple probe. 2. Check that the thermocouple butts are tight on both the tap and the pilot unit assembly. 3. If steps 1) and 2) do not cure the problem it is likely that the thermocouple is faulty. Remove and replace.
Fire operates well, but 'pops'.	<ol style="list-style-type: none"> 1. Popping is usually caused by the coals being placed to closely together. Ensure that the coal arrangement instructions given in this manual have been followed precisely. 2. If the injector has been removed or disturbed during the installation, ensure that the compression joint has been assembled correctly and is gas tight.
Excessive sooting.	<p>A small amount of sooting can occur on any fire of this type, especially those operating on LPG.</p> <ol style="list-style-type: none"> 1. Excessive sooting can be caused by incorrect arrangement of the coals. Ensure that the coal arrangement instructions given in this manual have been followed precisely. 2. The position of the injector is set in the factory, but if this has been disturbed during installation, then it should be reset. The correct position is when the injector points directly down the centre of the venturi. A blue flame with yellow tips should be produced in this position. 3. Check the flue pull. A 'lazy' chimney will not exhaust all of the soot particles from the burner. 4. Prolonged use of the minimum aeration setting on models with adjustable aeration. Return to the full aeration setting after cleaning.
Fire glows, but little or no flame is produced.	<p>This type of fire is designed to be efficient, and produce radiant heat in favour of expensive flames. The flames that are produced are 40-60mm long. If the flames are significantly shorter than this after the fire has been allowed to burn on MAX for 30 minutes, check the following.</p> <ol style="list-style-type: none"> 1. Ensure that the injector is clear from obstruction. 2. Ensure that the correct injector is fitted (see gas data). 3. Measure the gas pressures with the fire operating at MAX setting. The reading at the pressure test point should be as laid down in the gas data section of this manual. If the pressure is low, check the gas run for kinks, fiction producing fittings etc. Do not install more than 1.2 metres of 8mm gas line with natural gas fires. 4. Check that any restrictor elbow is fully open.

NOTE: ALWAYS USE GENUINE WONDERFIRE

SPARE PARTS

THIS APPLIANCE IS NOT SUPPLIED WITH A DECORATIVE FIREFRONT.
A SLOTTED FIREFRONT WITH A MINIMUM FREE AREA AS SHOWN IN FIGURE 16
MUST ALWAYS BE USED.

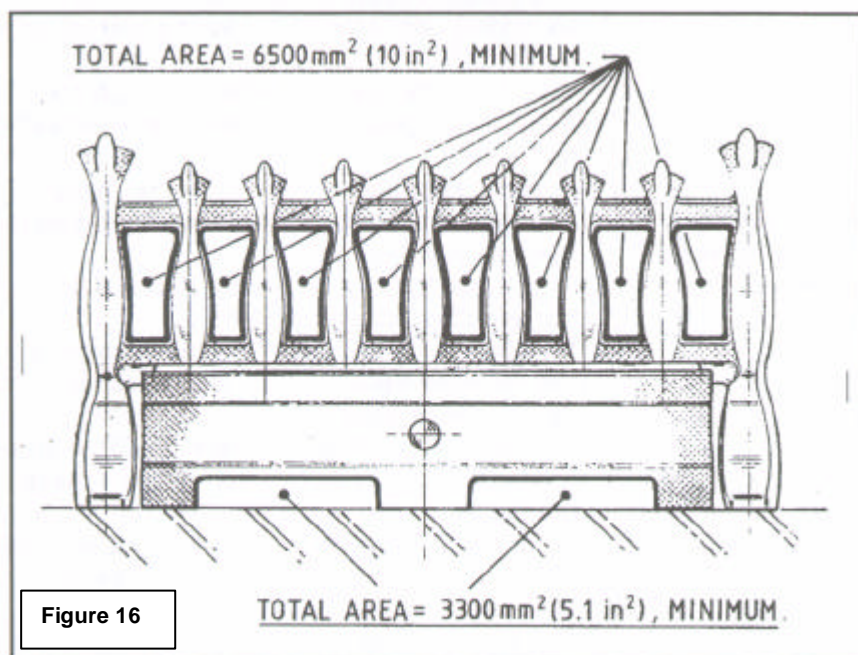

SHORT SPARES LIST

Never fit non-standard parts as this may invalidate the warranty.

Use only genuine Wonderfire replacement parts.

Use only the correct number of fibre bed components and install them as described in the procedures.

Description	Wonderfire Part number
Gas tap	9730096
Main injector (AF16NV)	9730073
Main injector (AF16XL)	9730087
Main injector (AF16NVP)	9730013
Pilot unit (NG)	9740029
Pilot unit (LPG)	9740030
Ceramic burner	9770086
Front coal	9770085
Coal matrix	9770084
Pack of dress coals	9780043
Lint guard/dust cage	0567619
Piezo Unit	9740040
Remote control handset	9550129
Receiver unit	9930054

Manufactured by Wonderfire ©1999

As our policy is one of continuous development, some details given in this manual may be subject to change.