

Instructions for Use Installation and Servicing

To be left with the user

Hideaway 100C FF

G.C. No. 41-047-42

Hideaway 115C FF

G.C. No. 41-047-43

Chimney Fanned Flue Boiler

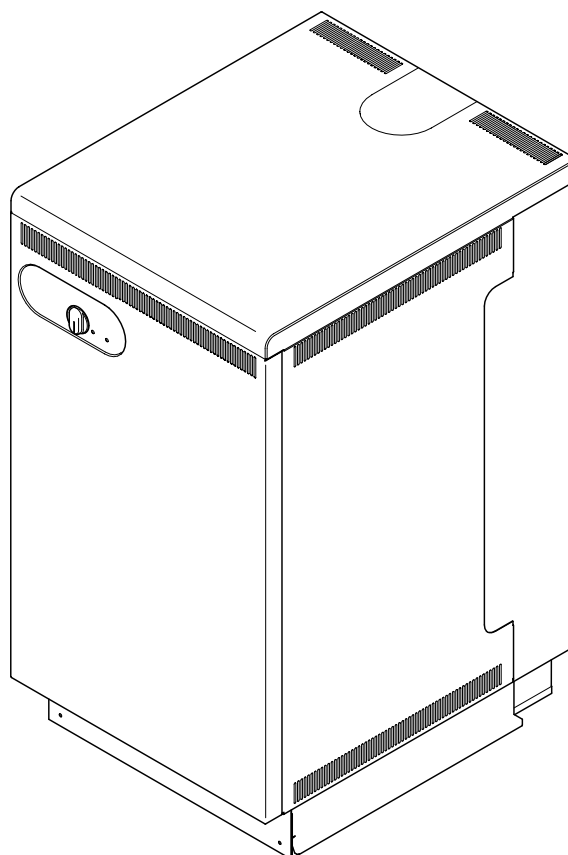

Guarantee Registration

Thank you for installing a new Glow-worm appliance in your home.

Glow-worm appliances are manufactured to the very highest standard so we are pleased to offer our customers a Comprehensive First Year Guarantee.

We recommend you complete and return as soon as possible your guarantee registration return literature, supplied in the document envelope.

If your guarantee registration return literature is missing you can obtain a copy or record your registration by telephoning the Glow-worm Customer Service number 01773 828100.

For customer service call:

(01773) 828100

Technical helpline: (01773) 828300

For General and Sales enquiries:

Tel. (01773) 824141

Fax: (01773) 820569

To register your Glow-worm appliance call:

0800 073 2142



Contents

The instructions consist of three parts, User, Installation and Servicing Instructions. The instructions are an integral part of the appliance and must, to comply with the current issue of the Gas Safety (Installation and Use) Regulations, be handed to the user on completion of the installation.

CONTENTS	DESCRIPTION	SECTION	PAGE No.
INSTRUCTIONS FOR USE	Important Information		4
	Draining and Filling		5
	Appliance Introduction		5
	Appliance Safety Devices		5
	Maintenance and Servicing		6
	Lighting the Boiler		7
INSTALLATION INSTRUCTIONS	General Data	1	8
	Water Systems	2	12
	Flue and Ventilation	3	13
	Installation	4	15
	Electrical Wiring	5	20
	Commissioning	6	21
	Instructions to the User	7	23
SERVICING INSTRUCTIONS	Servicing	8	23
	Fault Finding	9	26
	Replacement of Parts	10	29
	Spare Parts	11	31

Important Information

WARNINGS

Gas Leak or Fault

Turn off the gas emergency control valve immediately. Eliminate all sources of ignition, i.e. smoking, blowlamps, hot air guns etc. Do not operate electrical lights or switches either on or off. Open all doors and windows, ventilate the area.

Sheet Metal Parts

This boiler contains metal parts (components) and care should be taken when handling and cleaning, with particular regard to edges.

Sealed Components

Under no circumstances must the User interfere with or adjust sealed parts.

Gas safety (Installation and use) Regulations

In your interests and that of gas safety, it is the law that ALL gas appliances are installed and serviced by a **competent person** in accordance with the above regulations.

Testing and Certification

This boiler is tested and certificated for safety and performance. It is therefore important that no alteration is made to the boiler, without permission, in writing, from Glow-worm

Any alteration not approved by Glow-worm, could invalidate the certification, boiler warranty and may also infringe the current issue of the Statutory Requirements. The requirements are: The installation of this boiler must be carried out by a **competent person** in accordance with the current rules in force in the countries of destination at the time of installation. Manufacture's instructions supplied. Manufacture's instructions must not be taken as overriding statutory requirements.

CE Mark

This boiler meets the requirements of Statutory Instrument No. 3083 The boiler (Efficiency) Regulations, and therefore is deemed to meet the requirements of Directive 92/42/EEC on the efficiency requirements for new hot water boilers fired with liquid or gaseous fuels.

Type test for purposes of Regulation 5 certified by: Notified body 0086.

Product/production certified by: Notified body 0086.

The CE mark on this appliance shows compliance with:

1. Directive 90/396/EEC on the approximation of the laws of the Member States relating to appliances burning gaseous fuels.
2. Directive 73/23/EEC on the harmonization of the Laws of the Member States relating to the electrical equipment designed for use within certain voltage limits.
3. Directive 89/336/EEC on the approximation of the Laws of the Member States relating to electromagnetic compatibility.

Control of Substances Hazardous to Health

The adhesives and sealants used in this appliance are cured and give no known hazard in this state.

INSULATION PADS/CERAMIC FIBRE

These can cause irritation to skin, eyes and the respiratory tract.

If you have a history of skin complaint you may be susceptible to irritation. High dust levels are usual only if the material is broken.

Normal handling should not cause discomfort, but follow normal good hygiene and wash your hands before eating, drinking or going to the lavatory.

If you do suffer irritation to the eyes or severe irritation to the skin seek medical attention.

The insulation is composed of non-combustible material.

Electrical Supply

WARNING: This boiler must be earthed.

All system components shall be of an approved type and shall be connected in accordance with the current issue of BS7671 and any applicable local regulations.

All external wiring between the appliance and the electrical supply and earthing requirements shall comply with the current IEE Regulations.

Connection of the boiler and system controls to the mains supply must be through a common isolator and must be fused 3A, maximum. This method of connection must be by a fused double pole isolating switch, with a minimum contact separation of 3mm on both poles. The switch should be readily accessible and preferably adjacent to the appliance. It should supply the appliance only and be easily identifiable as so doing.

Alternatively, an unswitched shuttered socket outlet and 3A fused 3 pin plug, both to the current issue of BS1363 may be used provided that they are not used in a room containing a bath or shower.

Wiring to the boiler must be PVC 85°C insulated cable, not less than 0.75mm² (24/0.20mm).

Manual Handling Guidance

During the appliance installation it will be necessary to employ caution and assistance whilst lifting as the appliance exceeds the recommended weight for a one man lift.

In certain situations it may be required to use a mechanical handling aid.

Take care to avoid trip hazards, slippery or wet surfaces.

Heating System Controls

The heating system should have installed: a programmer and room thermostat controlling the boiler.

Thermostatic radiator valves may be installed, however they must not be fitted in a room where the room thermostat is located.

Important Information

Note: For further information, see the current issue of the Building Regulations, approved document L1, (in the UK) and the references:

- 1) GIL 59, 2000: Central heating system specification (CheSS) and
- 2) GPG 302, 2001: Controls for domestic central heating system and hot water. BRECSU.

Air in the heating system

Persistent air in the heating system may indicate leaks in the system or corrosion taking place. Call your Installation/Service company.

Boilers Installed in a Compartment

If the boiler is fitted in a compartment, cupboard etc., do not obstruct the purpose built compartment vents or the grill on the boiler.

Do not use the compartment for storage purposes.

Protection Against Freezing

In this boiler there is a built- in frost protection which will cause the boiler, when it is switched off at the control knob, to operate in the event of the water temperature in the boiler dropping below 5°C. The boiler will switch off again when the temperature of the water in the boiler reaches about 13°C. This will only protect the central heating system if the external controls are set so that the pump runs continuously, that is they are calling for heat.

NOTE: The frost protection will not operate if the electrical supply is turned off.

If the boiler is to be out of use for any period of time during severe weather conditions we recommend that the whole of the system including the boiler, be drained off to avoid the risk of freezing up. If an immersion heater is fitted to the hot water cylinder make sure it is switched off.

Draining and Filling

Draining and filling

Caution: The boiler must only be drained and filled by a **competent person**.

If the boiler is to be out of use for any period of time during severe weather conditions we recommend the whole system including the boiler, be drained off to avoid the risk of freezing up. If an immersion heater is fitted to the hot water cylinder make sure it is switched off.

WARNING: Do not operate the boiler without water.

If in doubt, consult your servicing company.

Appliance Introduction

Introduction

The Glow-worm Hideaway C FF series are fanned flue boilers with a chimney flue adapter. They provide heating and if required, an indirect domestic hot water supply.

The boiler is of the I_{2H} category for use only with **Natural Gas (G20)** as distributed in the United Kingdom and Ireland and cannot be used on any other gas.

The boiler is automatic in operation, having only one user control, the boiler temperature control.

The installation of this boiler must be carried out by a **competent person** in accordance with the rules in force in the countries of destination.

Manufacturer's instructions must not be taken as overriding statutory requirements.

These instructions should be carefully followed for the safe and economical use of your boiler.

NOTE: The boiler serial number is marked on the data label attached to the heat shield under the control box. The 'Instructions for Use' section describes how to safely use the boiler.

Appliance Safety Devices

Air flow rate safety device

If the flue is obstructed the built in safety system will turn the boiler OFF. The boiler will be ready to operate when the fault has been cleared.

Electrical supply failure

The boiler will not operate without an electrical supply. Normal operation of the boiler should resume when the electrical supply is restored.

Reset any central heating system controls, to resume normal operation.

If the boiler does not resume normal operation it is advisable to consult your installation / servicing company.

Maintenance and Servicing

Cleaning

WARNING: This appliance contains metal parts (components) and care should be taken when handling and cleaning with particular regard to edges of sheet metal parts to avoid any possibility of personal injury.

The boiler casing can be cleaned with a damp cloth, followed by a dry cloth to polish.

Do not use abrasive or solvent cleaners.

Maintenance and Servicing

To ensure the continued efficient and safe operation of the appliance it is recommended that it is checked and serviced as necessary at regular intervals. The frequency of servicing will depend upon the particular installation conditions and usage, refer to guarantee registration with this literature.

If this appliance is installed in a rented property in the UK there is a duty of care imposed on the owner of the property by the current issue of the Gas Safety (Installation and Use) Regulations, Section 35.

Servicing/maintenance should be carried out by a **competent person** in accordance with the rules in force in the countries of destination.

To obtain service, please call your installer or (Glow-worm's own service organisation) using the telephone number on the inside front cover of this literature.

Please be advised that the 'Benchmark' logbook should be completed by the installation engineer on completion of commissioning and servicing.

All CORGI Registered Installers carry a CORGI ID card, and have a registration number. Both should be recorded in your benchmark Logbook. You can check your installer is CORGI registered by calling CORGI direct on: 01256 372300.

Spare Parts

Remember, when replacing a part on this appliance, use only spare parts that you can be assured conform to the safety and performance specification that we require. Do not use reconditioned or copy parts that have not been clearly authorised by Glow-worm

If a part is required contact (Glow-worm's own service organisation) using the telephone number on the inside front cover of this booklet.

Please quote the name of the appliance, this information will be on the name badge on the front of the appliance.

If in doubt seek advice from the local gas company or (Glow-worm's own service organisation) using the telephone number on the inside front cover of this booklet.

Boiler casing

CAUTION: Do not remove or adjust the casing in any way, as incorrect fitting may result in faulty operation. If in doubt, consult your installation/service company.

Instructions for Use

To Turn the Appliance On

Do not operate the boiler without water.

Turn the electrical supply on to the boiler and check that all remote controls are calling for heat. The fan will operate.

It should be noted that this is a fanned flue appliance and fan operation may be heard.

Turn the boiler temperature control clockwise to any position between "0" and "Max", see diagram 1.

"Max" is approximately 82°C (180°F).

The boiler lighting operation is now automatic as follows:

The fan operates and after a short period of time, the spark ignition operates, the solenoid opens, then the burner will light shown by the burner ON indicator (green) on the control panel lighting up.

The burner will remain alight until switched off by the control thermostat or any remote control.

NOTE: If the boiler is turned OFF at the boiler temperature control, wait at least 30 seconds before switching on again.

When the boiler switches off, the burner will go out.

The automatic lighting sequence will operate again when heat is required.

If the reset/standby indicator lights, turn the boiler temperature control to "0" (off), wait 30 seconds, then repeat the lighting instructions.

To Turn the Appliance Off

For short periods, turn the boiler temperature control fully anti-clockwise to "0" (off), the reset/standby indicator will be on.

To relight, turn the boiler temperature control to any position between "0" and "MAX".

For longer periods, turn the boiler temperature control fully anti-clockwise to "0" (off) and switch off the electrical supply to the boiler.

To relight follow the lighting sequence given above.

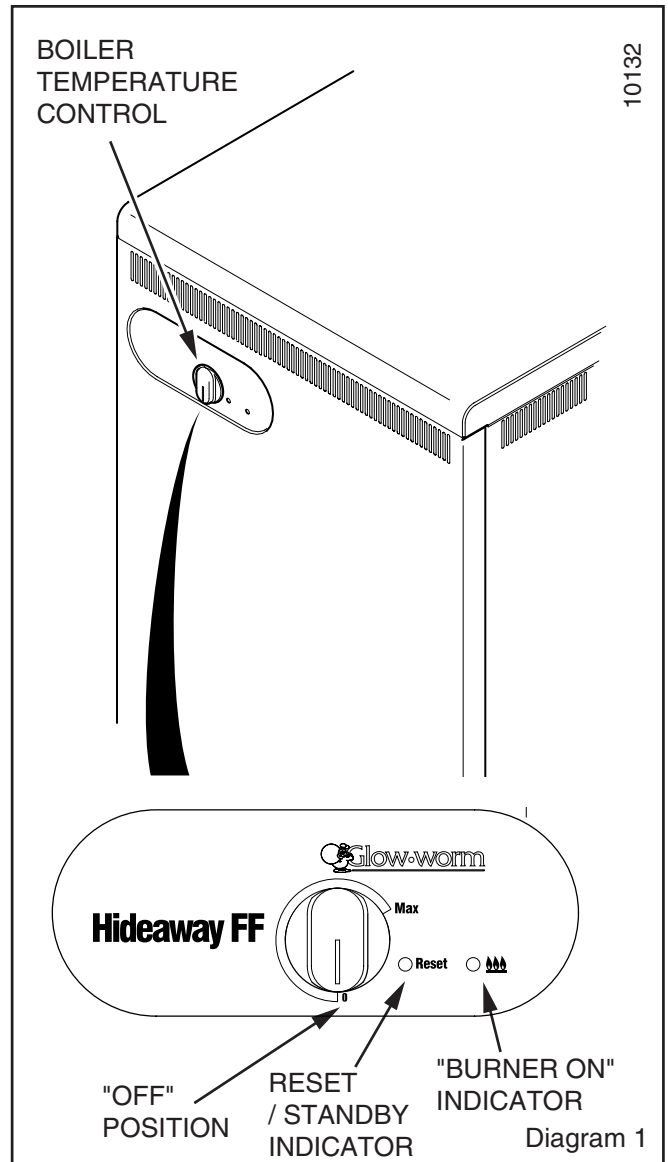

1 General Data

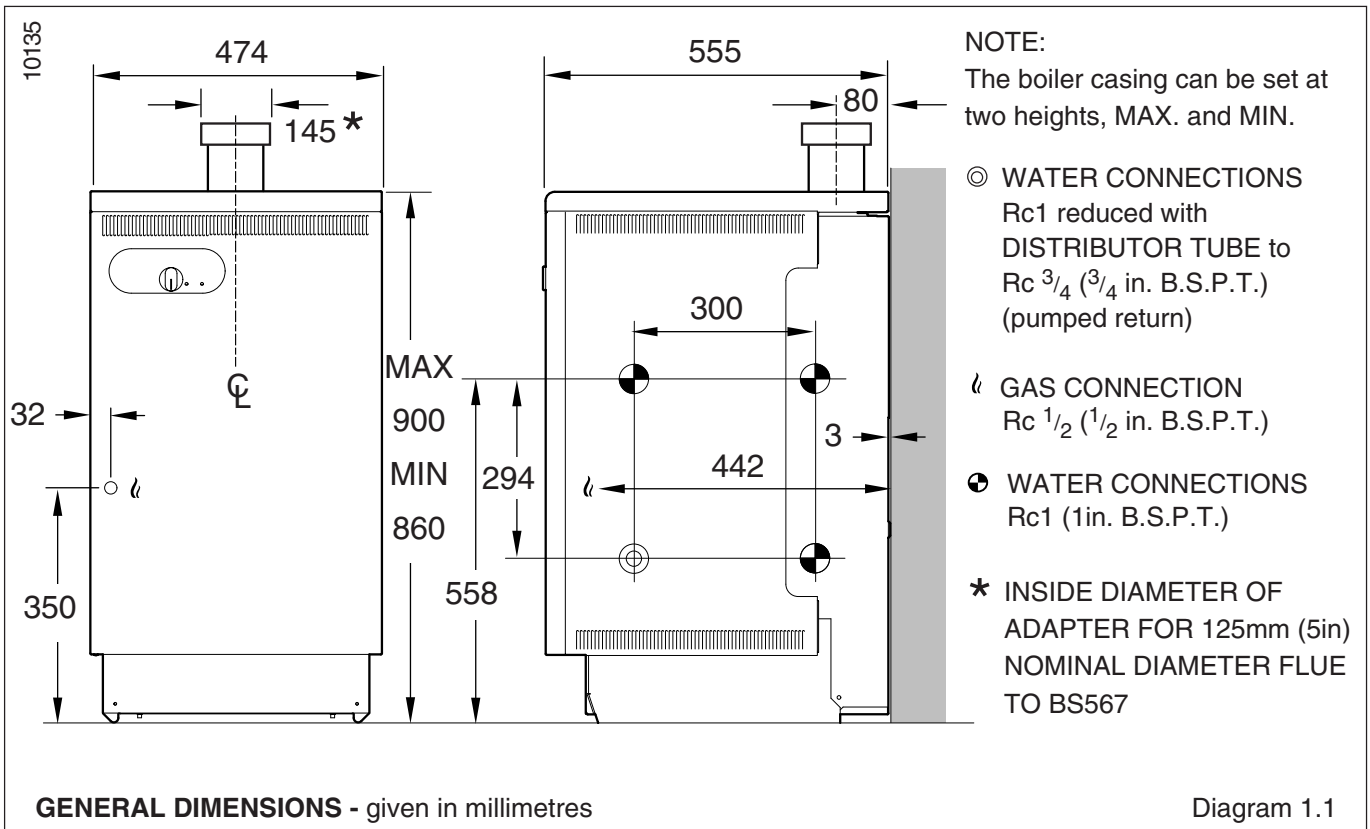

Important Notice

This boiler is for use only on **Natural Gas (G20)** as distributed in the United Kingdom and Ireland and cannot be used on any other gas. This boiler must be installed by a **competent person ONLY**.

Wherever possible, all materials, appliances and components to be used shall comply with the requirements of applicable British Standards.

Where no British Standard exists, materials and equipment should be fit for their purpose and of suitable quality and workmanship.

Refer to Manual Handling Operations, 1992 regulations.

1.1 Technical Data

Refer to diagrams 1.1, 1.2, and 1.3.

All dimensions are given in millimetres (except as noted).

Approximate weight of complete boiler and packaging:
143kg (315lb)

Water content : 11.7 litre (2.57 gallons)

Gas connection : Rc1/2 (1/2in BSPT)

Water connection : Rc1 (1in BSPT)

Electrical supply : 230V~50Hz, fused 3A

Burner : Aeromatic

The Seasonal Efficiency Domestic Boilers UK (SEDBUK) is "D", 100C FF = 78.9% 115C FF = 78.7%.

The value is used in the UK Government's Standard Assessment Procedure (SAP) for energy rating of dwellings. The test data from which it has been calculated have been certified by B.S.I.

1.2 Range Rating

See diagrams 1.2 and 1.3.

1.3 Statutory Requirements

The appliance is suitable only for installation in GB and IE and should be installed in accordance with the rules in force.

In GB the installation of the boiler must be carried out by a **competent person** as described in the following regulations:

The manufacturer's instructions supplied.

The Gas Safety (Installation and Use) Regulations.

The appropriate Buildings Regulations either The Building Regulations, The Building Regulations (Scotland), The Building Regulations (Northern Ireland).

The Water Fittings Regulations or Water byelaws in Scotland.

The Health and Safety at Work Act, Control of Substances Hazardous to Health (COSHH).

The Current I.E.E. Wiring Regulations.

Where no specific instructions are given, reference should be made to the relevant British Standard Code of Practice.

In IE, the installation must be carried out by a **competent person** and installed in accordance with the current edition of I.S.813 "Domestic Gas Installations", the current Building Regulations and reference should be made to the current ETCI rules for Electrical Installation.

In GB the following Codes of Practice apply:

BS4814, BS6798, BS5440 Part 1 and 2, BS5546 Part 1, BS5449, BS6891, BS6700, BS7074 Part 1 and 2, BS7593, BS7671.

In IE: I.S.813, BS5546, BS 5449, BS 7074, BS 7593.

Manufacturer's instructions must not be taken as overriding statutory requirements.

1 General Data

1.4 B.S.I Certification

This boiler is certificated by B.S.I., for safety and performance. It is, therefore, important that no alteration is made to the boiler unless agreed, in writing, by Glow-worm

Any alteration not approved by Glow-worm, could invalidate the B.S.I. certification, boiler warranty and could infringe the current issue of the Statutory Requirements.

1.5 Gas Supply

The gas installation shall be in accordance with the relevant standards.

In GB this is BS6891.

In IE this is the current edition of I.S.813 "Domestic Gas Installations".

The supply from the governed meter must be of adequate size to provide a steady inlet working pressure of 20mbar (8in wg) at the boiler.

On completion test the gas installation using the pressure drop method and suitable leak detection fluid, purge in accordance with the current issue of BS6891.

1.6 Electrical

WARNING: This boiler must be earthed.

The electrical installation must be carried out by a **competent person**. All external components shall be of the approved type and shall be connected in accordance with the current issue of BS7671 and any local regulations which apply.

External wiring must be correctly earthed, polarised and in accordance with the relevant standards.

In GB this is BS 6891.

In IE this is the current edition of I.S.813 "Domestic Gas Installations".

Connection of the boiler and any system controls to the mains supply through an unswitched shuttered socket outlet and 3A fused 3 pin plug, both to the current issue of BS1363. Alternatively, a 3A fused double pole isolating switch may be used, having a minimum double pole contact separation of 3mm, serving only the boiler and system controls.

Heat resistant cable of at least 0.75mm² (24/0.20mm), to the current issue of BS6500 Table 16, must be used for all connections within the boiler casing, to the control box, pump etc.



		HEPWORTH HEATING LTD., BELPER, DERBYS. DE56 1JT		10144
HIDEAWAY 100C FF		2000463402		
Electrical Supply 230V ~ 50Hz	49W Fused at 3A	GC No.41-047-42	TYPE : B22	
For use on I _{2H} G20- 20mbar.		NOx Class 1		
This boiler is intended exclusively to be installed on a gas supply with a governed meter.		 0086 GB IE		
HEATING CIRCUIT PMS = 2.5 bar		0086/AP/041		
INJECTOR: 3.8mm PART No. 2000461897				
HOT BURNER PR - mbar (in.w.g)		9.3 (3.7)		
HEAT INPUT NETT Q- kW (Btu/h)		31.59(107,785)		
HEAT OUTPUT P- kW (Btu/h)		29.31(100,000)		
SERIAL No.				

Diagram 1.2



		HEPWORTH HEATING LTD., BELPER, DERBYS. DE56 1JT		10147
HIDEAWAY 115C FF		2000463452		
Electrical Supply 230V ~ 50Hz	49W Fused at 3A	GC No.41-047-43	TYPE : B22	
For use on I _{2H} G20- 20mbar.		NOx Class 1		
This boiler is intended exclusively to be installed on a gas supply with a governed meter.		 0086 GB IE		
HEATING CIRCUIT PMS = 2.5 bar		0086/AP/041		
INJECTOR: 3.9mm PART No. 205746				
HOT BURNER PR - mbar (in.w.g)		9.7 (3.9)		
HEAT INPUT NETT Q- kW (Btu/h)		37.30(127,268)		
HEAT OUTPUT P- kW (Btu/h)		33.70(115,000)		
SERIAL No.				

Diagram 1.3

1 General Data

1.7 Condensate Drain

A plastic drain pipe may need to be fitted to allow discharge of condensate to a drain.

Condensate should, if possible, be discharged into the internal household draining system. If this is not practical, discharge can be made externally into the household drainage system or a purpose designed soak away, see section 4.11 for more details.

1.8 Boiler Location

This boiler is not suitable for outside installation.

The boiler must not be installed in a room used or intended to be used as sleeping accommodation or a room containing a bath or shower.

In GB this is the current I.E.E. WIRING REGULATIONS and BUILDING REGULATIONS.

In IE reference should be made to the current edition of I.S.813 "Domestic Gas Installations" and the current ETCI rules.

The boiler casing can be fitted at two heights. Refer to diagram 1.4.

The boiler is assembled at the factory with the control box and heat shield fitted in the lower position.

The boiler must stand on a level floor, conforming with local authority requirements and building regulations.

The base temperature is within the requirements of the current issue of BS5258. The boiler may stand on a wooden floor but a metal base plate is required to protect plastic tiles and similar floor coverings.

Suitable installation clearance needs to be available at the sides of the boiler to facilitate direct connection of pipework and making good around the flue assembly. The actual clearance required will vary with site conditions.

When the boiler is to be installed level with work surfaces and the like, minimum clearances should be provided as shown in diagram 1.5. Work tops which overhang the cupboard sides, almost in contact with the casing top, require a larger minimum air gap. Flush sided fixtures require the same overall minimum space but can have a reduced air gap on one side.

Boilers to be installed under work tops or fixtures, should be positioned to provide minimum clearances as shown in diagram 1.6. To facilitate minimum clearances it may be necessary to modify kitchen units and fixtures.

Combustible material must be a minimum of 25mm (1in) away from the flue components, see diagram 1.6.

A front access clearance for servicing of 700mm, should be provided.

The boiler can be installed within a cupboard, refer to minimum ventilation and clearances as shown in diagram 1.7

If the boiler is to be installed in a cupboard or compartment, make sure that nothing will obstruct the openings/vents in the compartment.

A compartment used to enclose the boiler must be designed and constructed specifically for this purpose. An existing cupboard or compartment modified for the purpose may be used. Details of essential features of cupboard or compartment design are given in the current issue of BS6798.

Where the installation of the boiler will be in an unusual location, special procedures are necessary the current issue of BS6798 gives detailed guidance on this aspect.

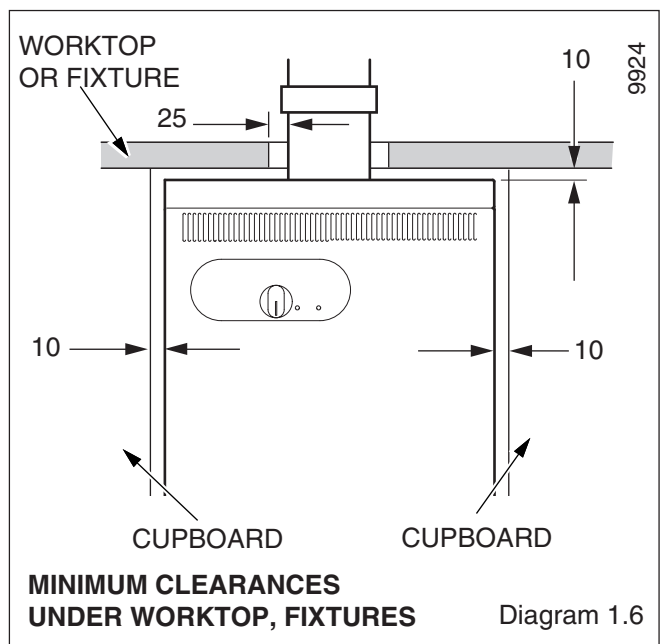
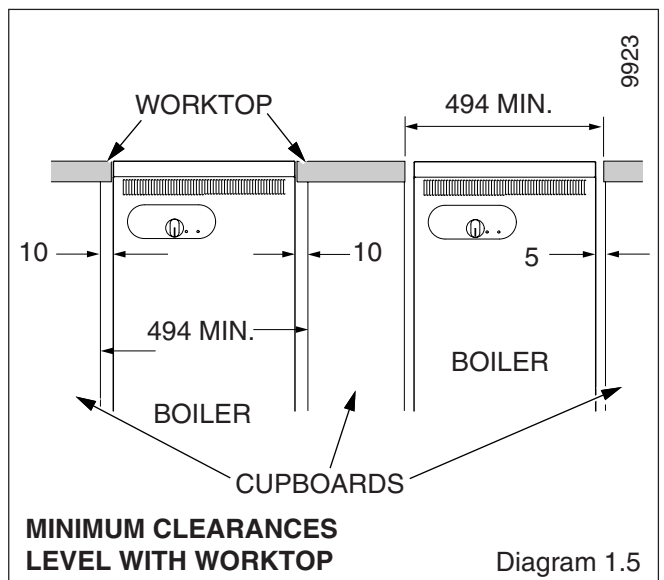
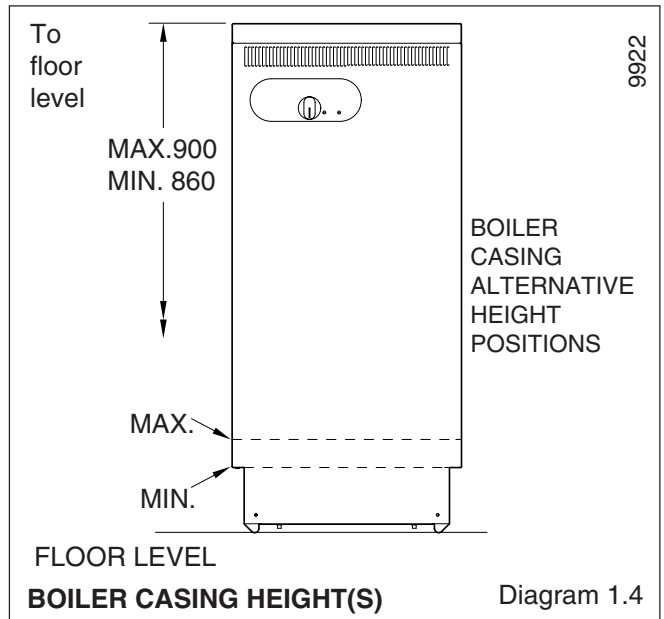

1 General Data

1.9 Heating System Controls

The heating system should have installed: a programmer and room thermostat controlling the boiler.

Thermostatic radiator valves may be installed, however they must not be fitted in a room where the room thermostat is located.

NOTE: For further information, see the current issue of the Building Regulations, approved document L1, and the references:

- 1) GIL 59, 2000: Central heating system specification (CheSS) and
- 2) GPG 302, 2001: Controls for domestic central heating system and hot water. BRECSU.

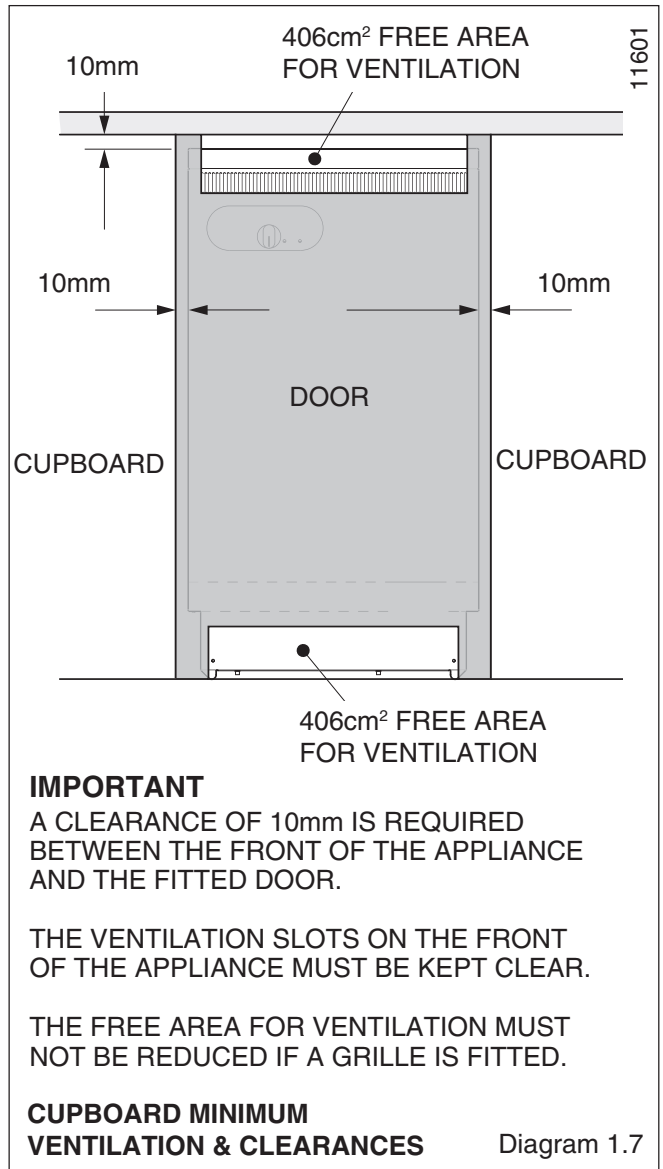

2 Water Systems

The installation of the boiler must comply with the requirements of the current issue of BS6798, in Ireland, refer also to the current edition of I.S.813 "Domestic Gas Installations".

In GB it is necessary to comply with the Water Supply (Water Fittings) Regulations 1999 (for Scotland, the Water Byelaws 2000, Scotland).

To comply with the Water regulations your attention is drawn to: The Water Regulations guide published by the Water Regulations Advisory Service (WRAS) gives full details of the requirements.

In IE the requirements given in the current edition of I.S.813 "Domestic Gas Installations" and the current Building Regulations must be followed.

It is recommended that plastic pipes for primary pipework should not be used for this boiler.

2.1 Water Pressure Head

The boiler shall only be connected to a cistern water supply with a minimum head of 1 metre (3ft3in) and a maximum head of 27metres (90ft) which has an open vent in the system.

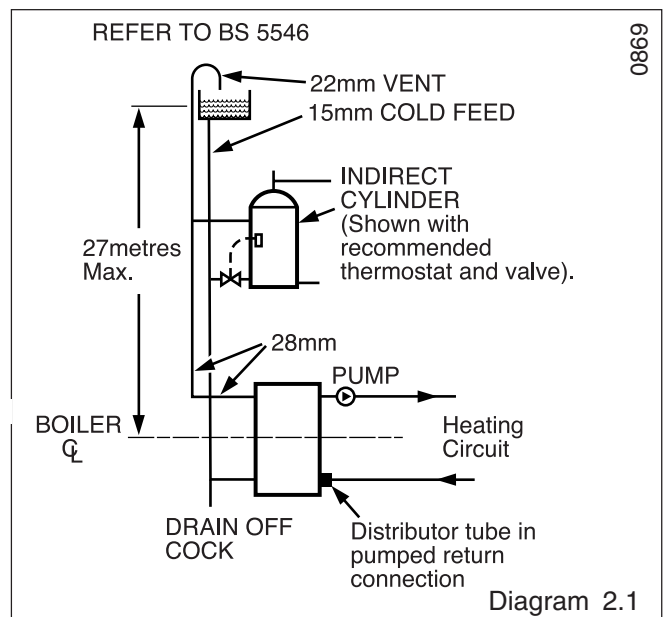

2 Water Systems

The working pressure must be within the range 0.1bar to 2.7bar (1.3 to 39lbf/in²).

The boiler MUST NOT be connected to a sealed water system.

2.2 Inhibitor

Attention is drawn to the current issue of BS5449 and BS7593 on the use of inhibitors in central heating systems.

If an inhibitor is to be used in the system, contact should be made with the inhibitor manufacturers so that they can recommend their most suitable product.

When using in an existing system take special care to drain the entire system, including the radiators, then thoroughly clean out before fitting the boiler whether or not adding an inhibitor.

2.3 Gravity Domestic and Pumped Heating

It is recommended that a cylinder thermostat is used to prevent the stored water temperature becoming unnecessarily high when the central heating pump is off.

The domestic primary flow and return must be 28mm o.d. The installation must comply with the current issue of BS5546 and BS6700, see diagram 2.1.

If the above conditions cannot be met, it is suggested that a fully pumped system be used.

2.4 Pumped Heating and Hot Water

Where a single flow and return is taken from the boiler, a minimum static head of 1 metre (3ft3in) must be provided between the water line of the feed tank and the centre of the waterway, see diagram 2.2.

2.5 Circulation Pump

Normally the pump should be set to give a temperature difference of 11°C (20°F) across the boiler. At the appropriate pumped flow rate the pressure loss through the boiler can be found from the graph, diagram 2.3.

Use a pump with integral valves or fit isolating valves as close to the pump as possible.

2.6. Cylinder

For all systems supplying domestic hot water the cylinder must be indirect.

2.7 Safety Valve

A safety valve need not be fitted to an open vented system.

2.8 Draining Tap

A draining tap must be provided at the lowest points of the system which will allow the draining of the entire system, including the boiler and hot water cylinder.

Draining taps should be to the current issue of BS2879.

2.9 Thermostatic Radiator Valves

If thermostatic radiator valves are fitted care must be taken to ensure that there is an adequate flow rate through the boiler when they close, refer to the current issue of BS7478 for guidance. If fitted to all radiators ensure a bypass is fitted and adjust to achieve a temperature difference no greater than 20°C between flow and return with the thermostatic valves closed.

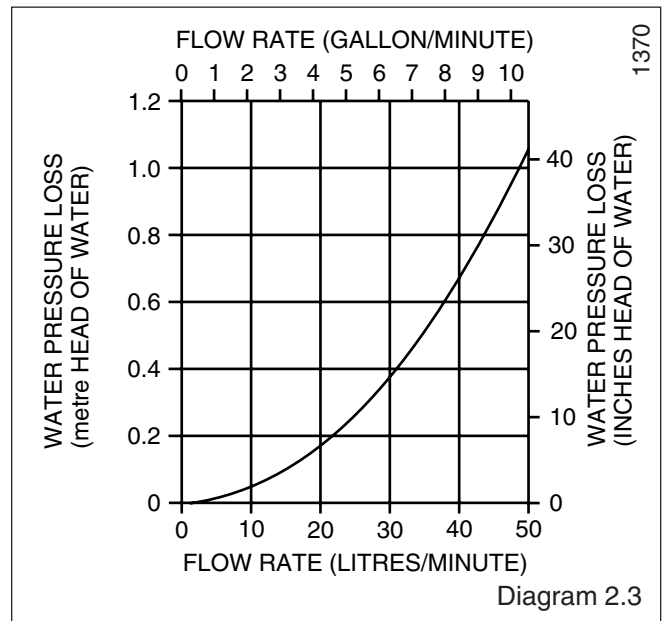
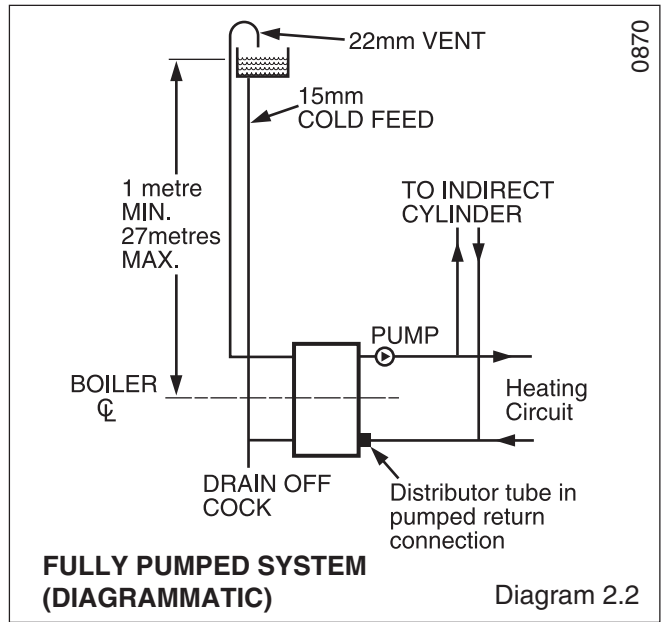

3 Flue and Ventilation

Important Notes

The flue must be installed in accordance with the rules in force in the countries of destination.

The flue must be in accordance with the current issue of BS5440 Part 1.

The Chimney Flue Adapter Kit (Part No. 2000461944) socket is designed to take flue pipes to the current issue of BS567. If a flue pipe to BS715 is to be used, an adapter must be fitted to the boiler flue socket.

The flue must be at least the equivalent to 1m vertical.

The maximum flue length must not exceed 15m vertical.

If the flue exceeds the following:

100CFF - 10m, 115CFF - 11m

the condensate drain on the chimney flue adapter must be connected and we would recommend that one of the following flue liners should be used or an equivalent specification:

Ritevent - Chimflex LW or SB

Selkirk - Selflex TS or TSE

An existing liner must be changed if there is any doubt that it will not operate safely throughout the life of any new appliance.

A drain point is incorporated on the chimney flue adapter to which a drain pipe can be connected, refer to section 4.10.

3.1 Flue Guidelines

The flue should be kept as short as possible. Horizontal or very shallow runs of the flue should be avoided as they encourage local cooling.

Always choose a flue route which will cause the least cooling of the flue.

90° elbows should not be used.

The existing flue may not be completely sound. Therefore, to prevent the possibility of leakage, additional sealing **MUST** be carried out between the base of the chimney and the flue liner.

The end of the flue liner at the chimney top must be adequately sealed and clamped, using proprietary fittings suitable for the flue liner used, see diagram 3.1.

The flue should, preferably, end above ridge height but at the least above the eaves of a pitched roof. Use a certificated terminal.

If the flue is pass through or near any combustible material it should be installed in accordance with the current issue of BS5440 Part 1.3. If in doubt seek advice from the local gas undertaking or Glow-worm

3.2 Chimney

An existing brick chimney must be thoroughly swept and all debris cleared away before lining.

Remove any damper or register plate. Alternatively it may be locked in the fully open position.

A flexible flue liner is preferred but a rigid liner may be used, with connection to the boiler flue socket made with a short vertical piece of flexible liner, see diagram 3.2.

The sealing plate also prevents debris falling and gives the flue better insulation, reducing the possibility of condensation, see diagram 3.1.

A chimney can be lined with a moisture resistant lining, such as salt glazed pipe, of an appropriate diameter as specified in the Building Regulations.

In the case of a salt glazed flue, it is recommended that a short vertical length of flue pipe be connected in such a manner that any condensation from the flue is not retained. Fix and seal it to the boiler flue socket and make good with an approved seal. It is also recommended that a permanent drain be fitted to the boiler.

If the flue is constructed from permeable material then it is strongly recommended that a metallic flue liner is installed.

If a flue and false chimney breast are to be constructed all openings for pipework to upper floors etc. must be sealed.

If a specially built compartment is constructed for the boiler, it must conform to the requirements of the current issue of BS5440 Part 1 and BS5871.

Check the system efficiency before installing the boiler.

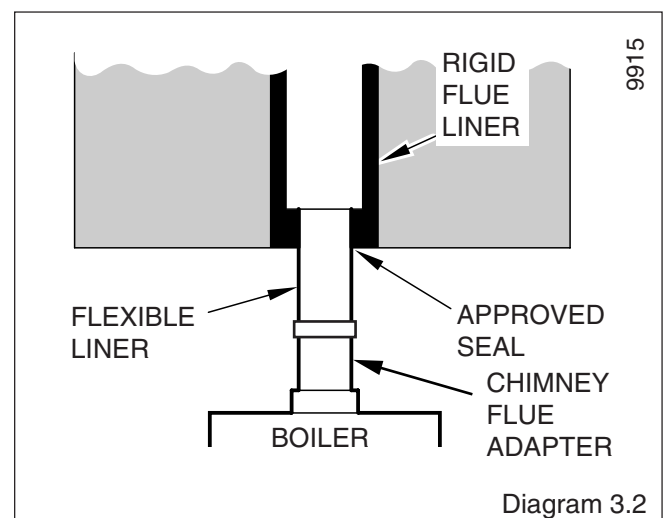
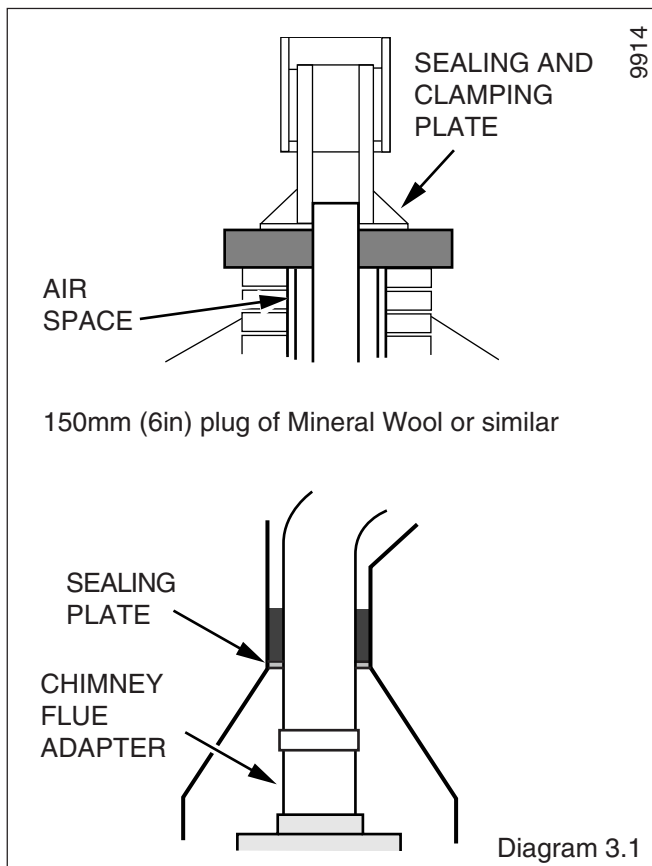

3 Flue & Ventilation

3.3 Timber Frame Buildings

If the boiler is to be installed in a timber frame building it should be fitted in accordance with the Institute of Gas Engineers document IGE/UP/7/1998. If in doubt seek advice from the local gas undertaking or Glow-worm

3.4 Ventilation for Boiler Installed in a Room or Space

If the boiler is to be installed in a room or space a purpose designed permanent ventilation opening, to supply air for combustion, must be provided on an outside wall to external air, refer to the current issue of BS5440 Part 2 for details.

The opening may be directly into the room or the space containing the boiler, or an outside wall of an adjacent room or space which has an internal permanent air vent, of the same size, into the room or space containing the boiler.

Do not ventilate through a bedroom, bedsitting room, private garage or a room containing a bath or shower.

When the boiler is installed in a room or internal space already containing other fuel burning appliances then the air supply of such appliances must be taken into account.

The ventilation opening areas are given in "Air Vent Table". The figures quoted refer to the minimum acceptable effective area.

3.5 Ventilation for Boilers Installed in a Compartment

When the boiler is fitted in a compartment, high and low level purpose designed, permanent openings must be provided to supply air for combustion and compartment ventilation.

The air vents must have minimum areas, see "Compartment Air Vent table". The figures quoted refer to the minimum acceptable effective area.

Both the high and low level openings must communicate with the same room, or must both be on the same wall to outside air.

If air vent grilles are fitted to a cavity wall, the opening through the wall must be ducted.

Where ventilation air to a compartment is taken from a room or space, then the room or space must be fitted with a ventilation opening as specified in "Air Vent Table".

For information regarding compartment requirements refer to the appropriate section of the current issue of BS6798.

3.6 Ventilation for Boilers installed in a Cupboard

For minimum ventilation and clearances for cupboard installation refer to section 1.8 and diagram 1.7.

3.7 Extract Fans

If an extract fan is fitted in the premises, there is a possibility that if adequate inlet openings are not provided, spillage of the products from the boiler could occur.

When openings are fitted in accordance with the current issue of BS5440 Part 2 and this section, extract fans should not cause down draught, but where such fan installations are found, a spillage test must be carried out in accordance with the current issue of BS5440 Part 1 and any corrective work done.

AIR VENT TABLE FOR ROOM SPACE INSTALLATIONS		
EFFECTIVE AREA OF VENT		
100C FF	126cm ²	20in ²
115C FF	152cm ²	24in ²

COMPARTMENT AIR VENT TABLE					
COMPARTMENT VENTILATION REQUIREMENTS		HIGH LEVEL VENT AREA		LOW LEVEL VENT AREA	
		VENTILATION FROM ROOM OR SPACE	100C FF	323cm ²	50in ²
	115C FF	374cm ²	58in ²	747cm ²	116in ²
FROM OUTSIDE	100C FF	162cm ²	25in ²	323cm ²	50in ²
	115C FF	187cm ²	29in ²	374cm ²	58in ²

4 Installation

General Installation Notes

The appliance pack contains :-

- Boiler.
- Casing panels, packed separately.
- Loose items fittings pack, see list in pack.

The flue adapter with flue extension is supplied separately.

Before installation of the boiler make sure that the location selected is in accordance with the requirements of Section 1.7.

4.1 Unpacking

The boiler casing panels are packed separately within the main carton and are designed to enable gas and water connections to be made before fitting the casing panels.

The casing brackets, flue restrictor, distributor tube and other loose items, are in the fittings pack.

IMPORTANT. With regards to the Manual Handling Operations, 1992 Regulations, the following operation exceeds the recommended weight for one man lift.

4.2 Water Connections - Gravity Domestic and Pumped Heating

Fit suitable fittings into the boiler tappings, see diagram 4.1. Make sure that all pipes are taken backwards and will clear the casings, see diagram 1.1.

NOTE: It is recommended that plastic pipes for primary pipework should not be used for this boiler.

Heating flow: Any one of the two upper connections may be used.

Domestic flow: Any one of the remaining upper connections may be used.

Heating return: The water distributor tube must be fitted into either of the front lower connections on all installations, see diagram 4.2. This tube is packed in the fittings pack.

Domestic return: Any one of the remaining lower connections may be used for the gravity domestic hot water return.

Fit plugs into any unused boiler tappings.

4.3 Water Connections - Fully Pumped Systems

Fit suitable fittings into the boiler tappings as required, see diagram 4.3. Make sure that all pipes are taken backwards and will clear the casings, see diagram 1.1.

NOTE: It is recommended that plastic pipes for primary pipework should not be used for this boiler.

It is important that all connections are made as shown in diagram 4.3.

Fit the water distributor tube into the return connection, see diagram 4.2. This tube is packed in the fittings pack.

Fit plugs into any unused boiler tappings.

4.4 Thermistor Pocket

Fit the thermistor phial pocket supplied, in the fittings pack, into the front tapping adjacent to the heating flow connection. Having chosen the flow connection and plugged the alternative connection.

Carefully unwind the thermistor capillary, insert phial fully into the pocket and secure with grommet moulded to the cable.

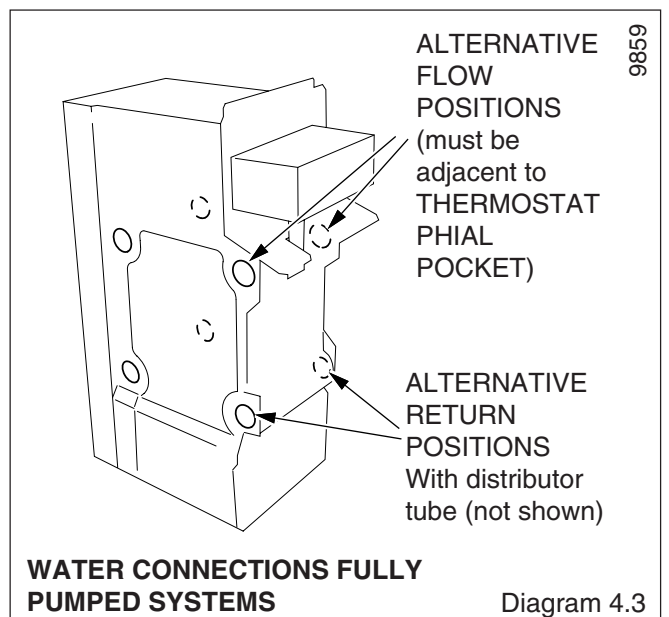
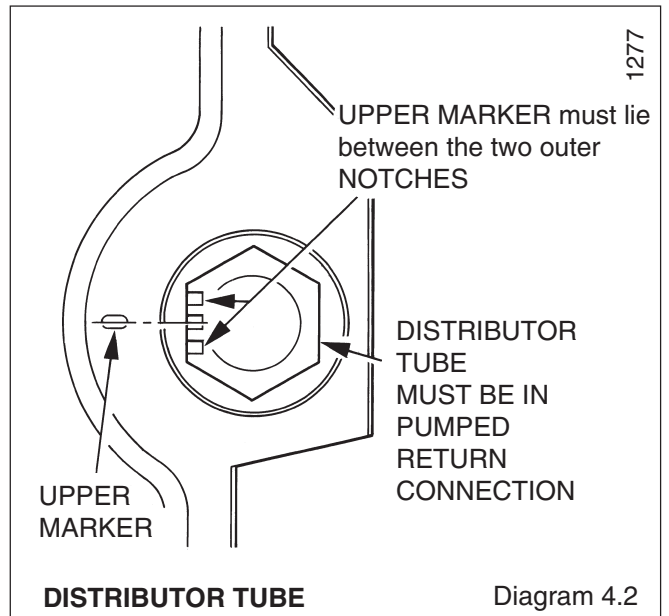
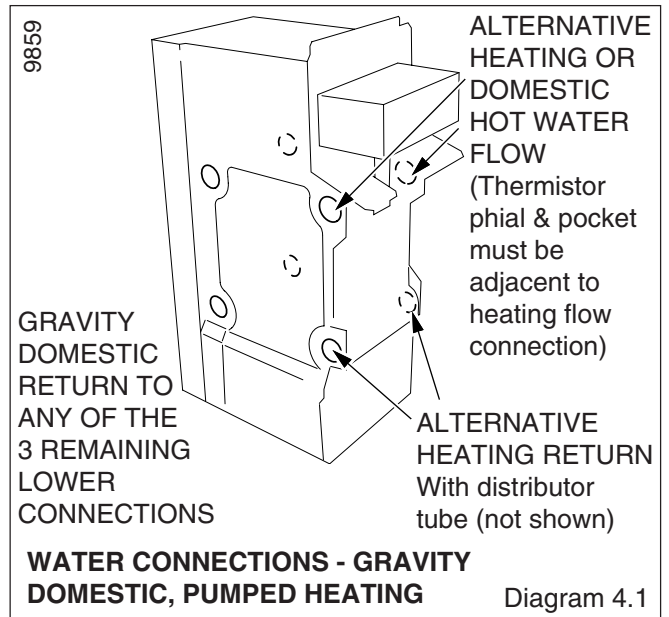

4 Installation

4.5 Pipework

It is essential that any pipework or fittings do not project more than shown in diagram 4.4.

Do not route any pipework, water or gas, across the front of the combustion chamber cover.

The gas pipework must be along the left hand side of the boiler.

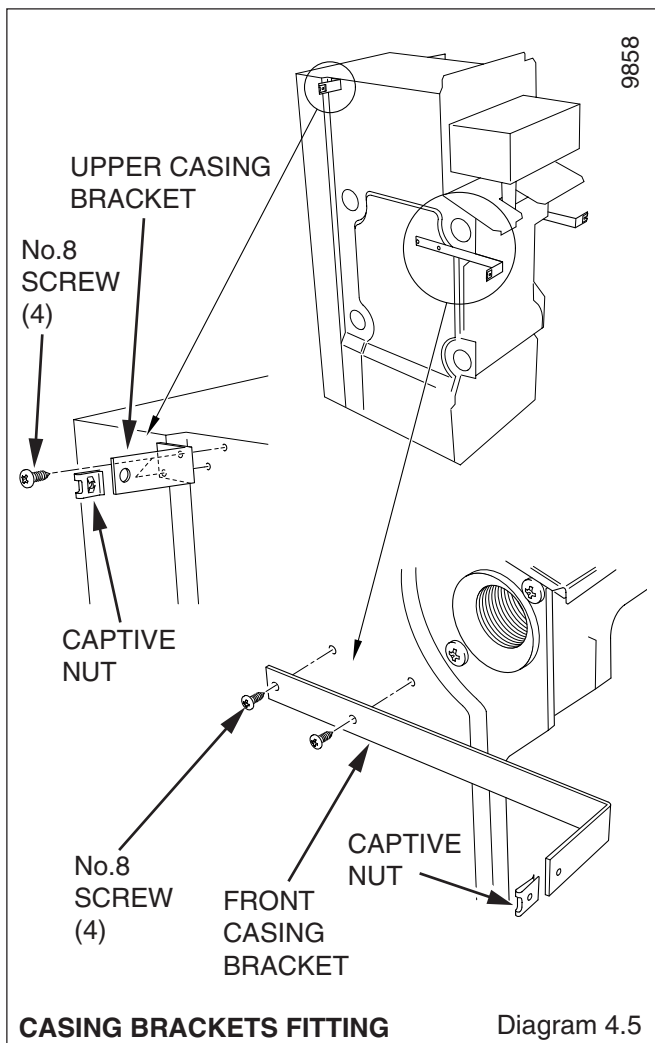
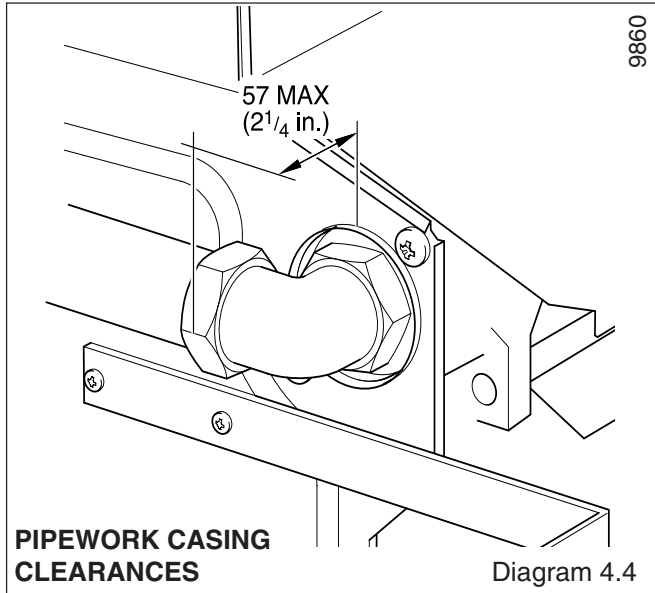

4.6 Casing Brackets

Fit the two upper and two front casing brackets shown in diagram 4.6, using the No.8 screws provided.

NOTE: The screws will already be fitted.

Push the captive nuts, supplied loose, on to the casing brackets as shown in diagram 4.5.

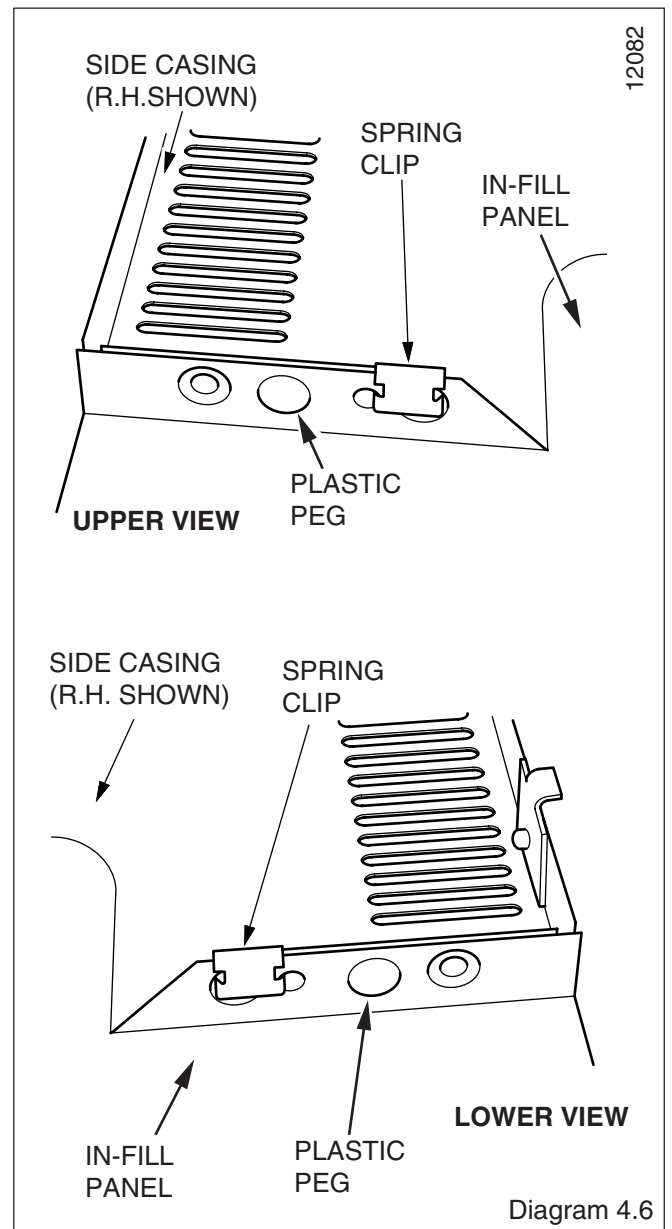

4 Installation

4.7 Side In-fill Panel (if required)

A side in-fill panel is supplied with the boiler, which can be fitted at the rear of the left or right hand side casing but can be discarded if the water connections are made on both sides of the boiler or if the boiler is screened by fixtures. The in-fill panel will usually be fitted on the side where there no pipework connections.

Insert the push fit plastic location peg, supplied, through the in-fill panel and side casing holes and secure with the spring clips, see diagram 4.6.

NOTE

The boiler is assembled at the factory with the control box and heat shield fitted in the lower casing height position.

4.8 Side Casings

Fit the side casings by locating their lugs into the appropriate slot in the boiler plinth, see diagram 4.7, depending on the required height, there are two options, see section 1.8.

Secure the casing sides to the front and rear upper casing brackets with self-tapping screws supplied, see diagrams 4.7 and 4.8.

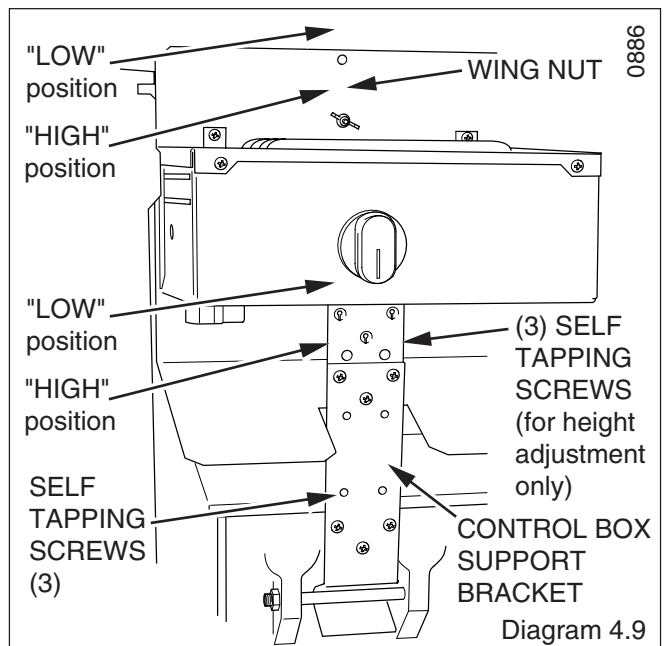
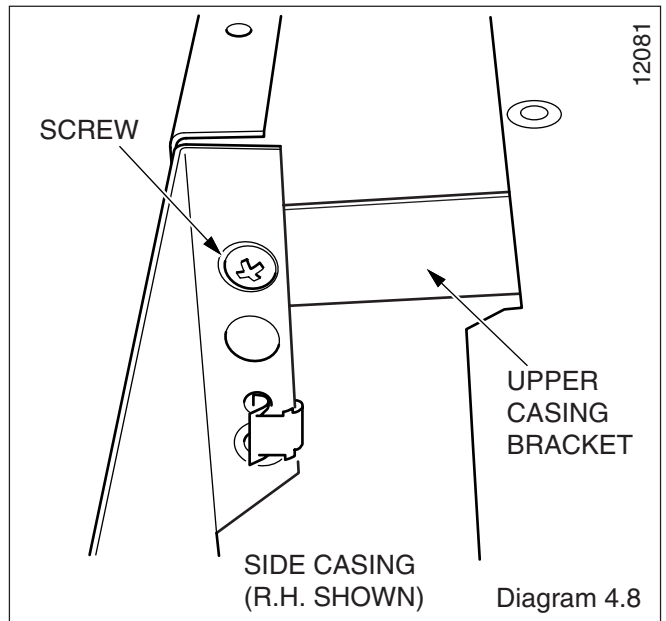
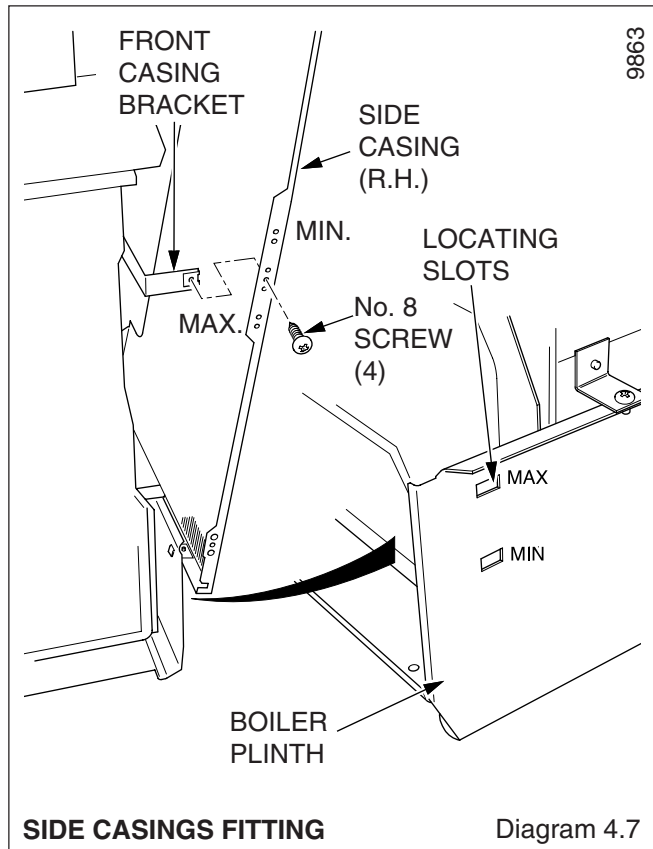

4 Installation

4.9 Flue / Boiler Connection

Remove the three self-tapping screws from the lower part of the control box support bracket, see diagram 4.9.

Undo the wing nut that secures the top of the heat shield and carefully hinge down control box and heat shield, see diagram 4.9.

Release the three toggle latches that secure the fan access door and remove, see diagram 4.10.

Remove the electrical connections from the fan by pulling the insulation boots only and disconnect the two air pressure tubes from the fan taking note of their positions, see diagram 4.11.

Remove the fan assembly from the flue hood by removing the securing screw, pull forward and lift up to release the 3 hooked securing lugs underneath the fan, see diagrams 4.11 and 4.12.

From the Chimney Flue Adapter Kit take the flue spigot, the gasket is supplied in the fittings pack.

Connect the flue spigot and gasket to the top flue outlet of the boiler using the self tapping screws provided, see diagram 4.13.

From the Chimney Flue Adapter Kit, take the chimney flue adapter and remove restrictor securing screw, select and fit appropriate restrictor -

100CFF: marked 'D'

115CFF: marked 'E'

then secure in place with the previously removed screw. To connect a condensate drain, remove plastic end stop by depressing the collet.

Slide the Chimney Flue Adapter into the flue spigot until it engages in the bayonet connection, then twist clockwise to lock, see diagram 4.13.

Rest the flue duct extension on the support bracket and engage into the chimney flue adapter, see diagram 4.14. Refit fan ensuring it is engaged into the flue duct extension and the securing lugs are located correctly into the flue hood, secure with fan securing screw. Replace electrical connections and air pressure tubes.

The polarity of the electrical connections is not important.

Make sure that the air pressure tubes are fitted as before, see diagram 4.11 and that the fan duct engages fully into the flue duct extension piece.

IMPORTANT. With regards to the Manual Handling Operations, 1992 Regulations, the following operation exceeds the recommended weight for one man lift.

Place the boiler in position taking care not to damage the casing panels.

Flue Connection

NOTE: Fix and seal the flue to the hood of the chimney flue adapter in accordance with normal practice.

The flue should be 125mm (5in) nominal diameter, refer to section 3.

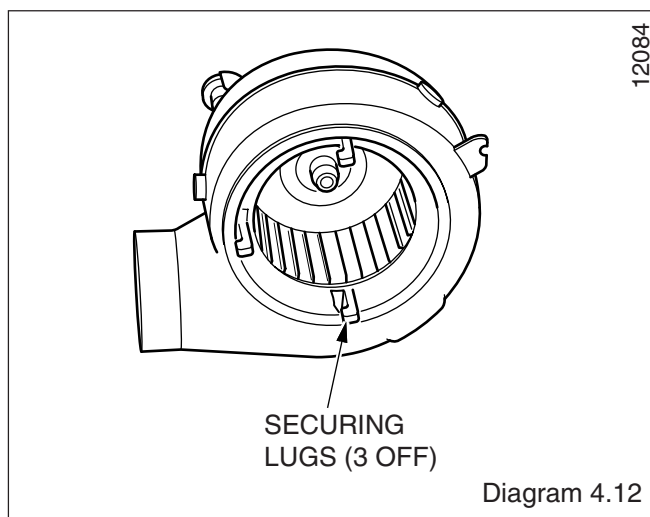
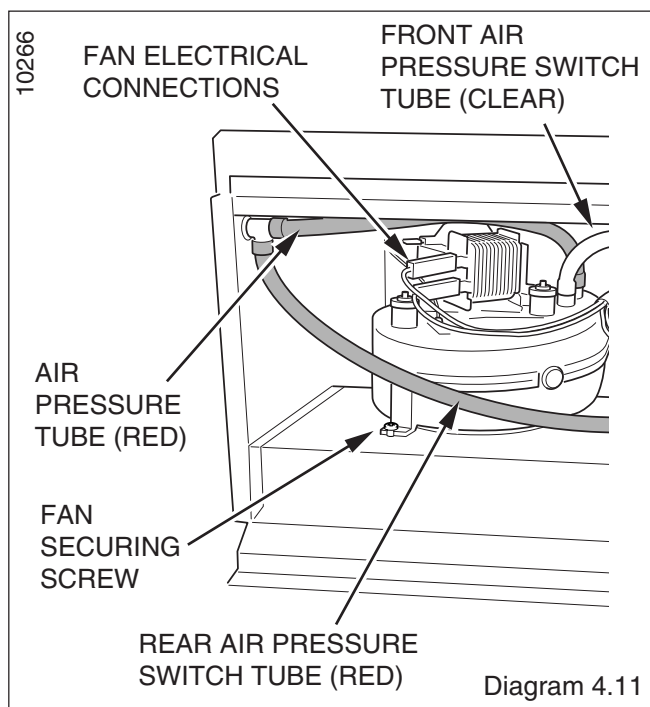
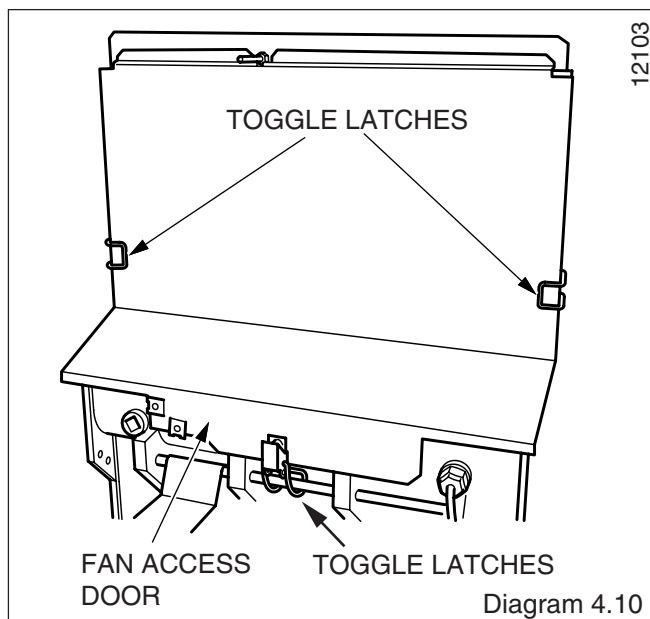

4 Installation

4.10 Water and Gas connections

Replace fan access door, heat shield and control box.

NOTE: When replacing the fan access door make sure the lip at the top of door fits into and behind the slotted bracket located at the top of the boiler.

As there are two casing height options, the control box height and the heat shield may have to be adjusted to suit your requirements.

Complete the water connections to the boiler.

Fill, vent and flush the system.

Check for any water leaks and put right.

Make the gas connection to the service cock, at the lower left hand side of the boiler, see diagram 1.1.

The whole of the gas installation, including the meter, should be inspected, tested for soundness and purged in accordance with the current issue of BS6891 and in IE the current edition of I.S. 813 "Domestic Gas Installations".

4.11 Condensate Drain Connection (If Applicable)

With reference to Section 3, should your flue be greater than the "Dry" flue length stated, then a condensation drain should be fitted.

To use the condensate drain connection on the chimney flue adapter, remove the end stop, see diagram 4.13. A 22mm plastic overflow pipe should be used to fit on to the drain connection and discharge to a drain. The drain pipe should have a fall of at least 2.5° away from the boiler and should incorporate a 'U' trap.

Condensate should, if possible be discharged into the household internal drainage system. If this is not practicable, discharge can be allowed into the external household drains or by a purpose designed soak away.

It is recommended that any external condensate drain is insulated and also preferably of 32mm diameter, to prevent freezing in adverse weather conditions.

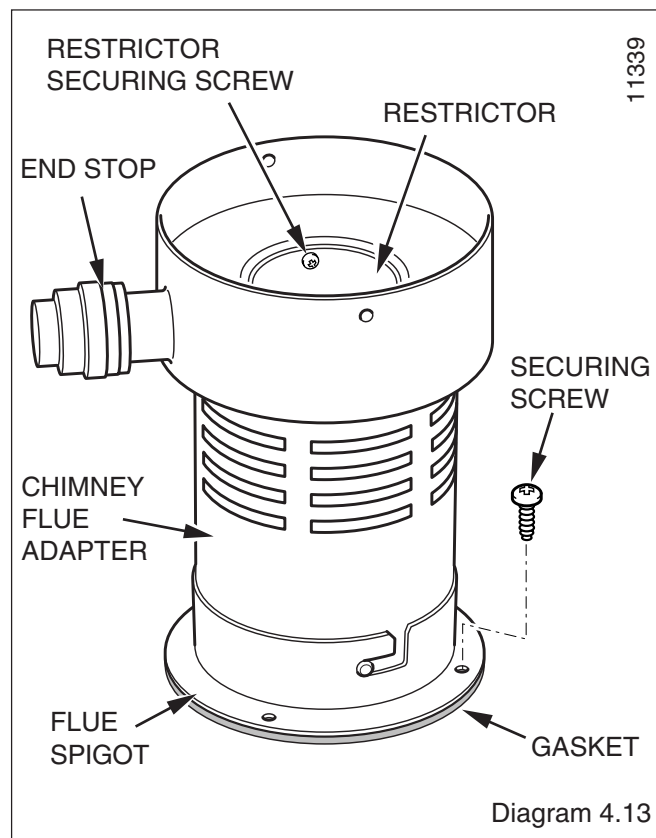

4.12 Top Casing

Refer to diagram 4.15.

Fit two plastic pegs, one on each side, in the holes on the top casing. The plastic pegs are a tight fit and are best pushed home with a flat faced tool.

Secure front of top casing with the two screws provided.

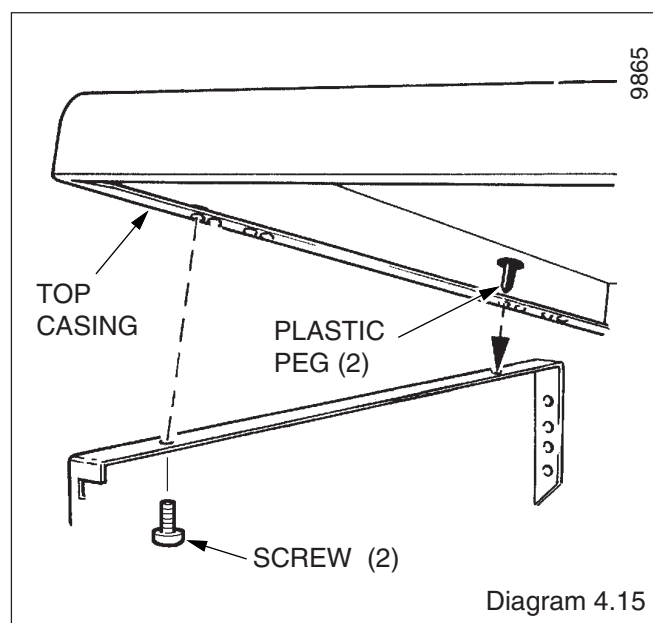
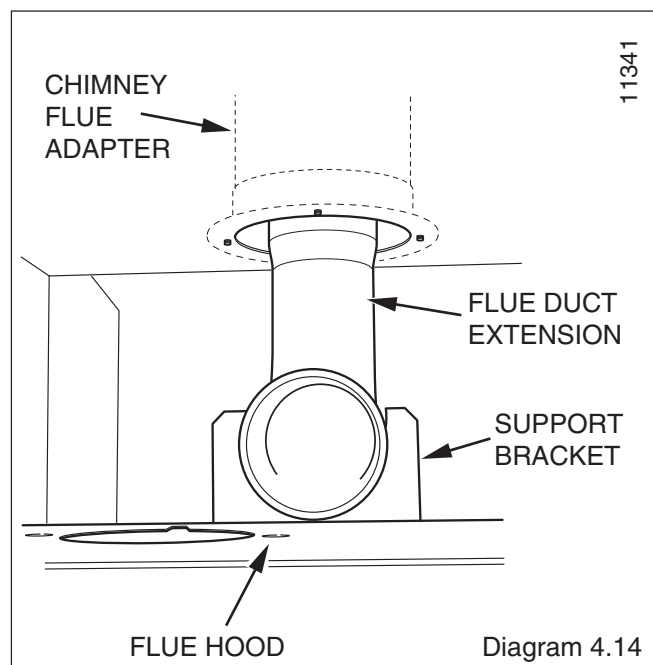

5 Electrical Wiring

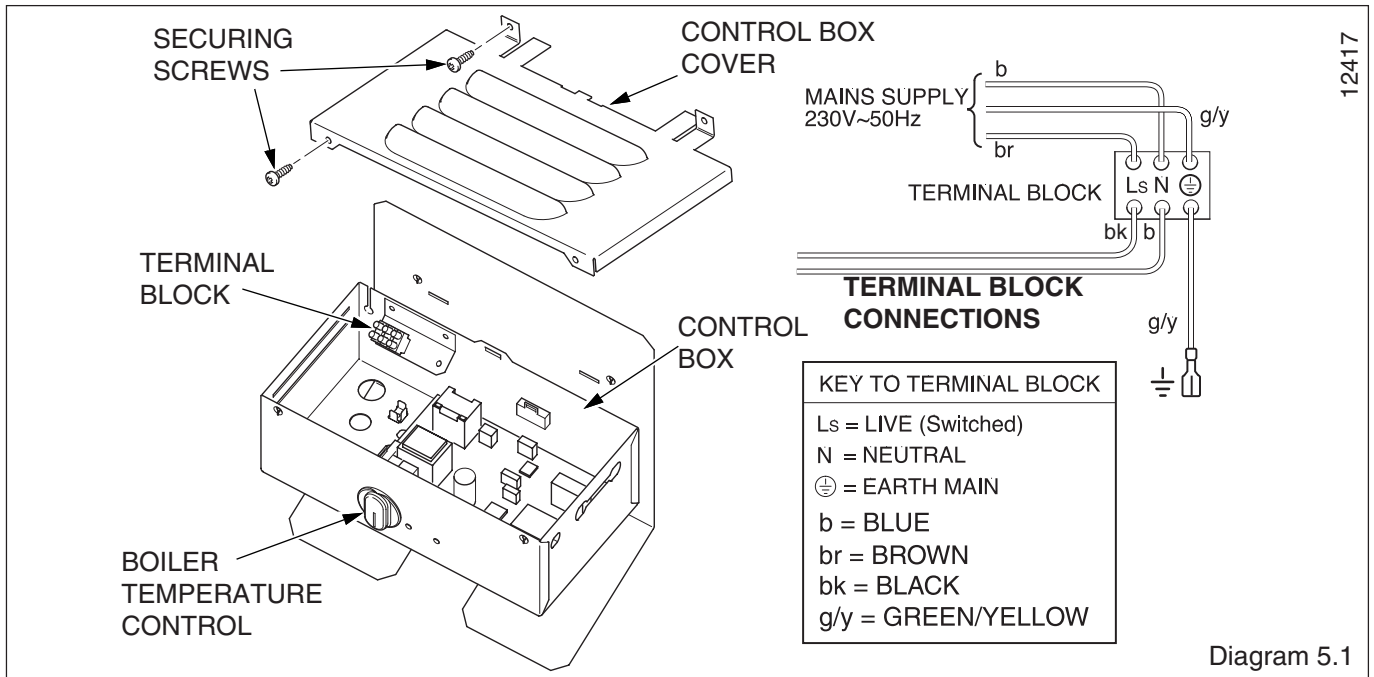

5.1 Control Box Access

Remove control box cover by undoing the four securing screws (two on control box, two on the heat shield) and lift off, see diagram 5.1.

5.2 Electrical Connections

WARNING: This boiler must be earthed.

Take care not to damage any internal wiring.

Using heat resistant (85°C) cable of at least 0.75mm² (24/0.2mm) and of a suitable length, route as shown in diagram 5.3. Thread through the grommet at the bottom rear of the control box, through the cable clamp and connect to appropriate terminals. Tighten cable clamp screws, see diagram 5.2.

Standard colours are, brown - live (L), blue - neutral (N) and green/yellow - earth (⊕).

The mains cable outer insulation must not be cut back external to the cable clamp.

Make sure the cable is suitably secured.

When making connections make sure that the earth conductor is made of a greater length than the current carrying conductors, so that if the cable is strained the earth conductor would be the last to become disconnected.

5.3 Pump Connection

The pump must be connected to the external controls.

5.4 Testing - Electrical

Checks to ensure electrical safety must be carried out by a **competent person**.

After installation of the system, preliminary electrical system checks as below should be carried out.

1. Test insulation resistance to earth.
2. Test earth continuity and short circuit of all cables.
3. Test the polarity of the mains.

The installer is requested to advise and give guidance to the user of the controls scheme used with the boiler.

Replace the control box cover.

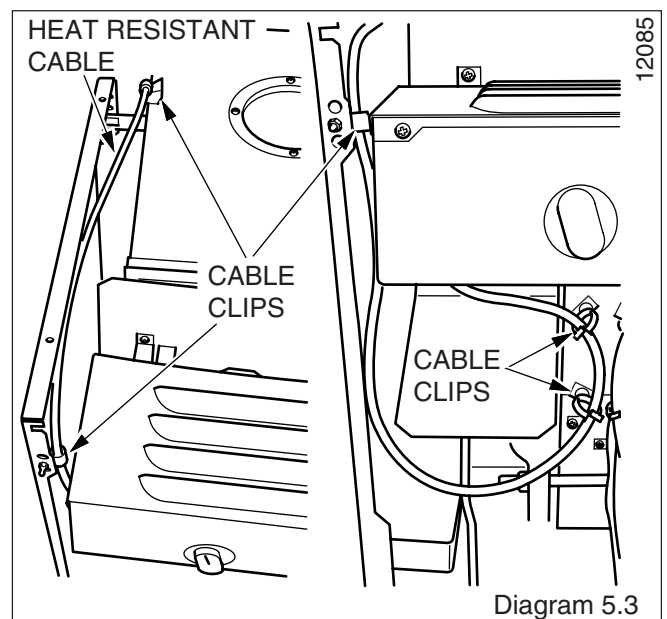
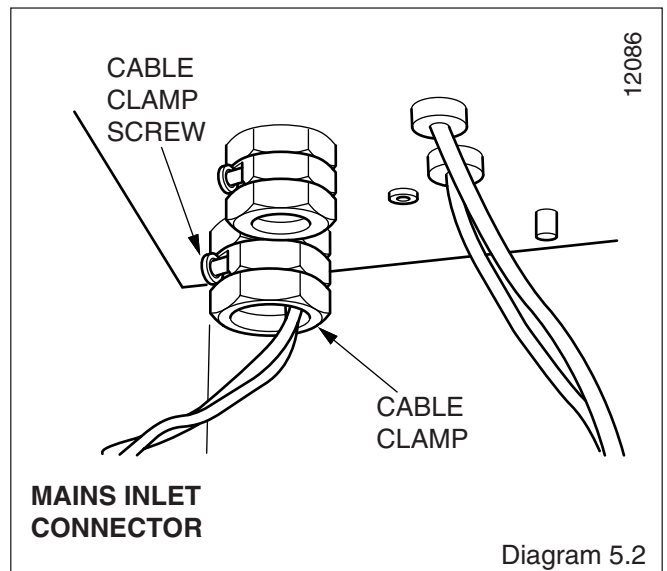

6 Commissioning

IMPORTANT NOTE: The **WARNING NOTICE** attached to the front casing must only be removed by the user.

Please ensure the "Benchmark" logbook is completed and left with the user, and the magnetic lighting instruction label is placed on the surface of the boiler casing.

6.1 All Systems

Commissioning should be carried out by a **competent person** in accordance with the current issue of BS6798.

WARNING: Do not operate the boiler without water.

UNDER ALL CIRCUMSTANCES the case must be correctly fitted and sealed, unless fault finding.

Make sure that the system has been thoroughly flushed out with cold water without the pump in place.

Refit the pump, fill the system with water, ensuring that all the air is properly vented from the system and pump.

6.2 Initial Lighting and Testing

CAUTION: This work must be carried out by a **competent person**, in accordance with the current issue of BS6798.

Make sure that all naked lights and cigarettes are extinguished.

Refer to 'Instructions for Use' and identify the controls.

Check that the boiler is isolated from the electrical supply.

Turn the gas service cock "On", see diagram 6.1.

Purge in accordance with the current issue of BS6891.

WARNING: The multifunctional control and fan operate on mains voltage, terminals will become live.

If programmer control is fitted, make sure it is in the ON mode.

Make sure that any remote controls are calling for heat.

Turn the boiler temperature control clockwise to "Max".

The ignition system will operate to light the boiler. After a pre-set time if ignition has not taken place the boiler will shutdown.

To re-start the lighting sequence, turn the boiler temperature control to "O", then fully clockwise to "Max".

"Max" is approximately 82°C (180°F).

After the burner has lit, the "Burner on" indicator on the control panel will come on.

Isolate the boiler from the electrical supply.

Loosen the burner pressure test point screw and connect a suitable pressure gauge, see diagram 6.1.

Switch on the electrical supply to the boiler.

WARNING: The multifunctional control and fan operate on mains voltage, terminals will become live.

6.3 Testing - Electrical

Turn the boiler temperature control knob fully clockwise to the maximum setting, which is approx. 82°C (180°F).

The lighting sequence is automatic as follows:

The fan will operate for a short period prior to the start of the ignition sparks. The gas valve solenoids will open and the burner will light. This is shown by the "Burner Lit" LED on the control panel lighting up.

The burner will stay alight until switched off, either by the temperature control or remote system control.

To make sure that the flame supervision device is working correctly the following should be done.

With the burner alight, turn the gas service cock 'OFF', see diagram 6.1.

After a short period the burner will go out but the fan will continue to run.

The correct working of the flame supervision device is shown by

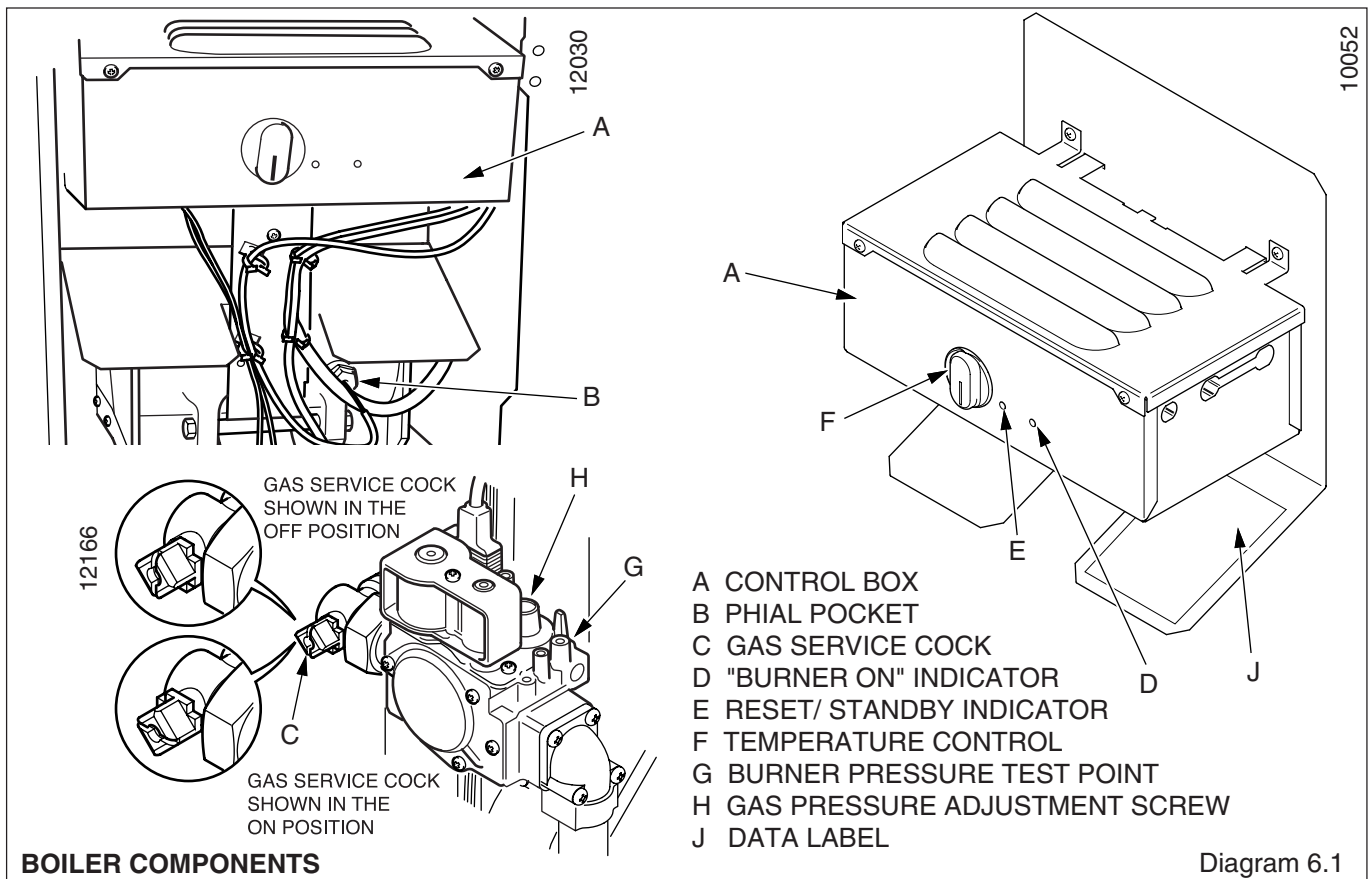

6 Commissioning

the 'Burner On' indicator going out and the lighting sequence starting up, as follows:

1. Fan continues to run and then switches off / slows down.
2. After approximately 5 seconds fan restarts / speeds up.
3. After a short period sparking begins and the boiler attempts to relight.

After shutting off the gas, the boiler will attempt to relight twice before shutting down. The following illumination will happen with the LED on the front of the control panel, "Reset" permanently ON and "Burner Lit" flashing fast (8 Hz).

If the above lighting sequence fails, refer to section 9 - Fault Finding.

To continue, turn the gas service cock 'On', see diagram 6.1.

To restart the lighting sequence, turn the temperature control knob to "O" then fully clockwise to "Max". After approximately 10 to 15 seconds the boiler will begin its ignition sequence.

During Normal Operation when the boiler switches 'Off', the burner will go out. The automatic lighting sequence will work again when heat is required.

6.4 Testing - Gas

With the boiler on proceed as follows:

Test for gas soundness around the boiler gas components using a suitable leak detection fluid, in accordance with the current issue of BS6891.

Check the burner gas pressure at least 10 minutes after boiler has lit, refer to Data Label, see diagram 1.2 and 1.3.

If necessary adjust the gas pressure to obtain the required setting turning screw anti-clockwise, to decrease pressure, see diagram 6.1.

Should any doubt exist about the gas rate, check it using the gas meter test dial and stop watch at least 10 minutes after the burner has lit, making sure that all other gas burning appliances and pilot lights are off.

Gas rate: **Hideaway 100C FF** : 3.3m³/h (115ft³/h)

Hideaway 115C FF : 3.8m³/h (136ft³/h)

is for guidance only, dependent on the heat setting.

Turn the boiler temperature control fully anti-clockwise to "0".

Isolate from the electrical supply.

Remove the pressure gauge from the test point and refit screw, making sure a gas tight seal is made.

When the boiler temperature control is turned to the "0" position, by hand, wait at least 30 seconds before turning On again.

There may be an initial smell given off from the boiler when new, this is quite normal and it will disappear after a short period of time.

6.5 Testing - All Water Systems

Allow the system to reach maximum working temperature and examine for water leaks.

There should be no undue noise in the system.

The boiler should then be turned off and the system drained off as rapidly as possible, whilst still hot.

Refill system.

6.6 Open Vented System

Ensure there is no pumping over of water or entry of air at the open vent above the feed and expansion cistern.

6.7 Adjustment - Fully Pumped Open Vented System

When commissioning the system the boiler should first be fired on full service, that is, central heating and domestic hot water. Adjust the pump to the system design setting, then balance the system, making adjustments as necessary.

6.8 Completion

Adjust the boiler temperature control and any system controls to their required settings. In addition it is necessary to complete the "Benchmark" logbook.

For IE, it is necessary to complete a "Declaration of Conformity" to indicate compliance to I.S.813. An example of this is given in the current edition of I.S.813.

Fit the bottom plinth panel and secure with two dog point screws, see diagram 6.2.

Finally fit the front panel by hooking under front of top panel locating on the two studs and securing at the bottom on to the bottom plinth panel with two screws, see diagram 6.3.

Testing Flue Gases: If any doubt exists that the flue products are not exhausting correctly. Investigate by the use of a gas analyser (FGA).

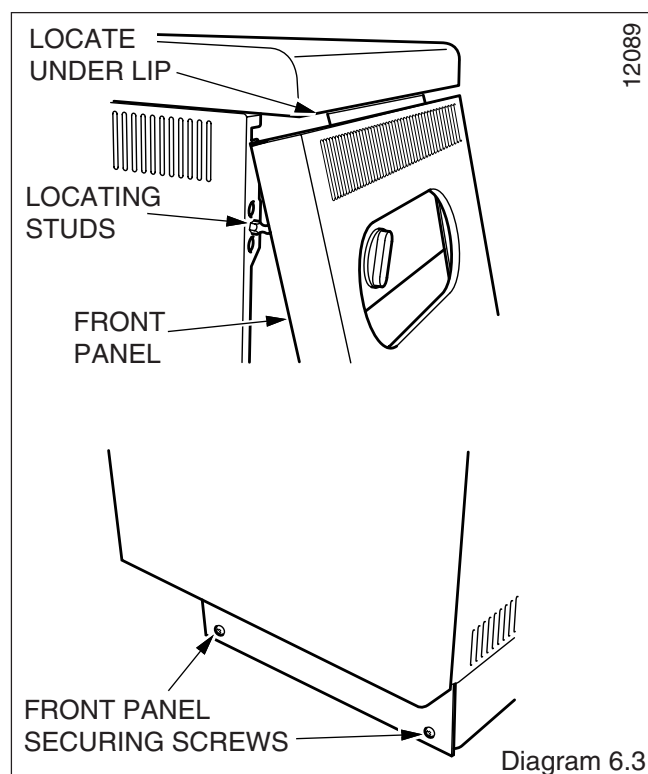
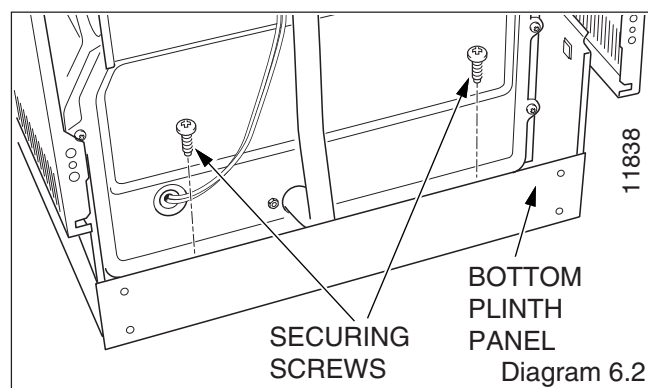

7 Instructions to the User

Instruct and demonstrate the safe and efficient operation of the boiler, heating system and domestic hot water system.

Advise the user, that to ensure the continued efficient and safe operation of the boiler, it is recommended that it is checked and serviced at regular intervals. The frequency of servicing will depend upon the particular installation and usage, but in general once a year should be enough.

Draw attention, if applicable to the current issue of the Gas Safety (Installation and Use) Regulations, Section 35, which imposes a duty of care on all persons who let out any property containing a gas appliance in the UK.

It is the Law that servicing is carried out by a **competent person**.

Advise the user of the precautions necessary to prevent damage to the system and building in the event of the heating system being out of use during frost and freezing conditions.

Reminder - Leave these instructions and the "Benchmark" logbook with the user.

8 Servicing

REMEMBER, When replacing a part on this appliance, use only spare parts that you can be assured conform to the safety and performance specification that we require. Do not use reconditioned or copy parts that have not been clearly authorised by Glow-worm

Products of Combustion Check

NOTE: To obtain a products of combustion reading, remove the front panel, see diagram 6.3 and remove the control box as described in the relevant paragraphs of section 4.9. Next, remove the cap from the sampling point, located on the top of the left hand side of the inner casing, see diagram 8.1.

Connect the analyser tube on to the nipple.

WARNING: The multifunctional control and fan operate on mains voltage, terminals will become live.

Switch on the electrical supply and gas supply then operate the boiler.

On completion of the test switch off the electrical supply and gas supply, remove analyser tube and replace sampling point cap.

Servicing

Before servicing turn off the gas and isolate the electrical supply to the boiler.

After completing a service always test for gas soundness, make electrical checks and carry out functional check on controls.

Unless stated otherwise all parts are replaced in the reverse order to removal.

8.1 Access

Remove the boiler front casing panel, refer to paragraph 6.8.

Remove the bottom plinth panel by unscrewing the two dog point screws securing the panel to the boiler plinth, see diagram 8.4.

Disconnect gas valve from gas cock and unplug electrical plug from gas valve, firstly removing electrical plug securing screw, see diagram 8.2.

Unclip electrical wires from control box support bracket, see diagram 8.3.

Undo the five self-tapping screws that secure the combustion chamber front and carefully withdraw it together with the burner and gas valve assembly, taking care not to strain the ignition, sensing and earth leads, see diagram 8.5.

NOTE: When replacing burner in combustion chamber make sure it fits correctly on the guides.

Disconnect the ignition, sensing and earth leads from the burner and remove by drawing the leads through the grommet, see diagram 8.5 and 8.9.

Remove the three self-tapping screws from the lower part of the control box support bracket, see diagram 8.6.

Undo the wing nut that secures the top of the heat shield and carefully hinge down control box and heat shield, see diagram 8.6.

Release the three toggle latches that secure the boiler access door and remove, see diagram 4.10.

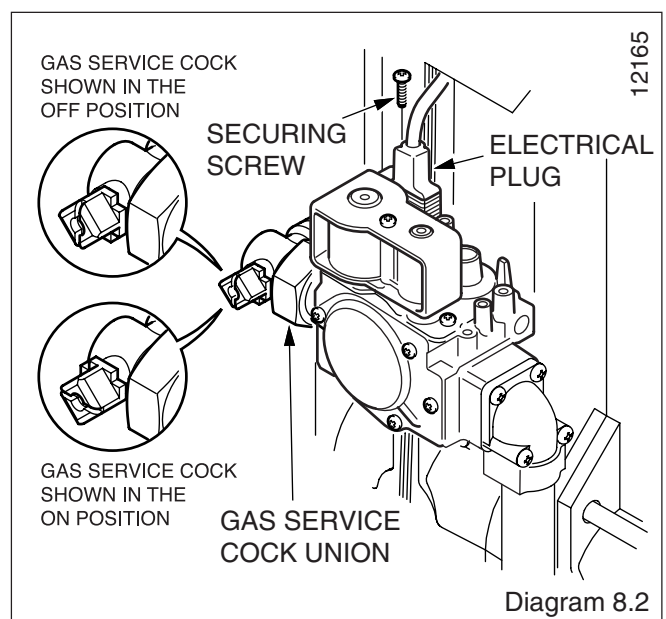
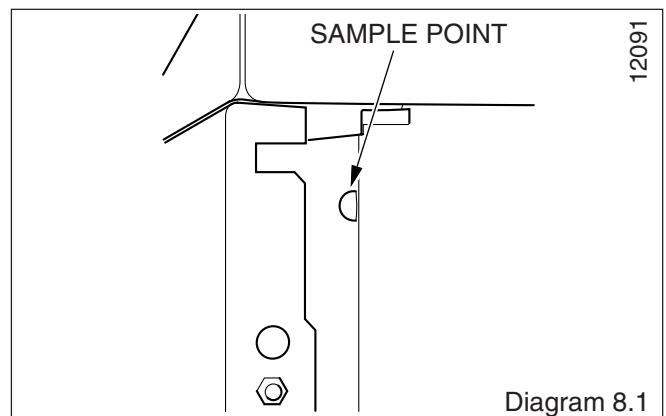

8 Servicing

NOTE: When replacing the fan access door make sure the lip at the top of door fits into and behind the slotted bracket located at the top of the boiler.

Refer to diagram 8.7.

Remove the electrical connections from the fan by pulling the insulation boots only.

Disconnect the two air pressure tubes from the air pressure switch and the red air pressure tube from the fan taking note of their positions.

Remove the flue hood and fan assembly by sliding back to disengage the retaining lugs then lift up.

When replacing the flue hood ensure that it rests on the guides and that the rear of flue hood is located under the pegs at the rear and pushed down and back fully.

IMPORTANT: When re-fitting fan check that it fits fully into the flue duct extension piece.

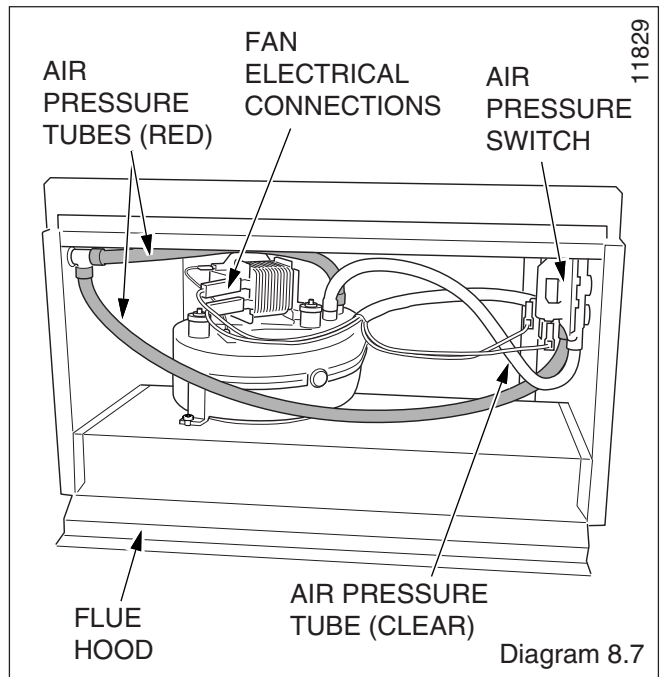
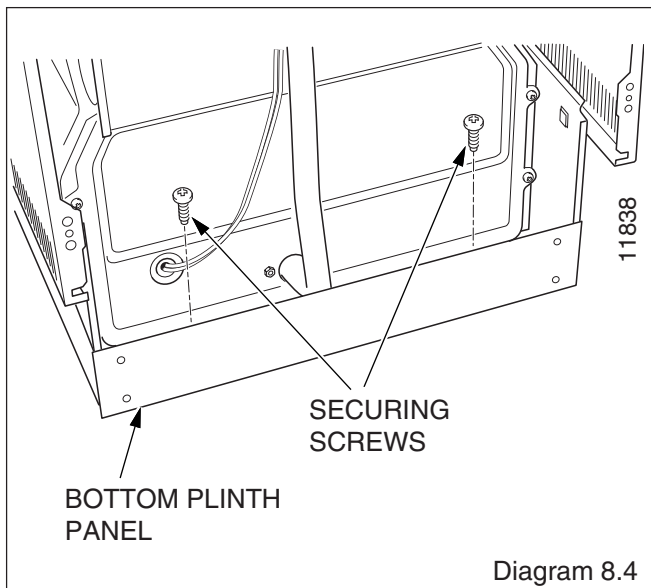
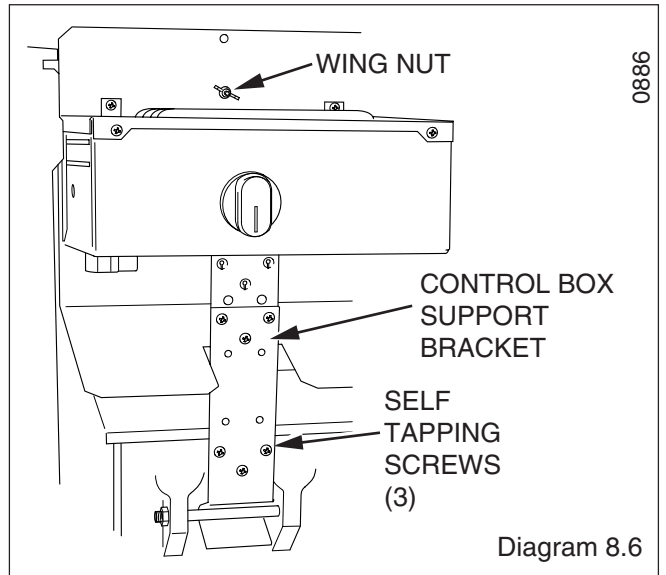
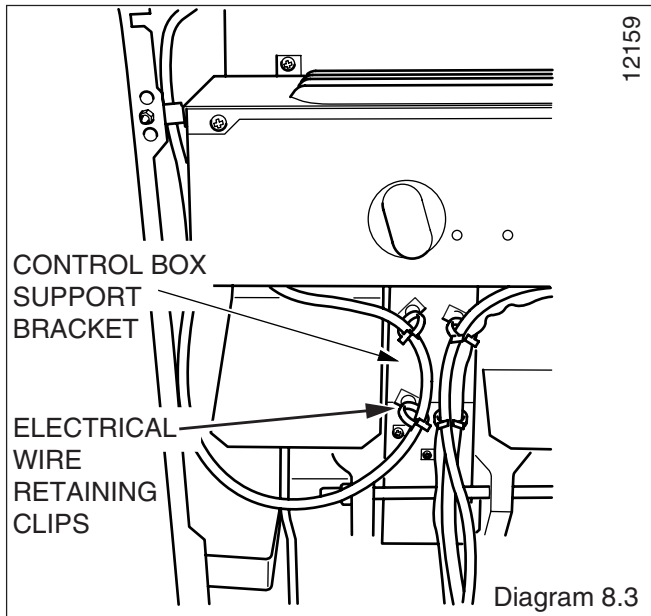
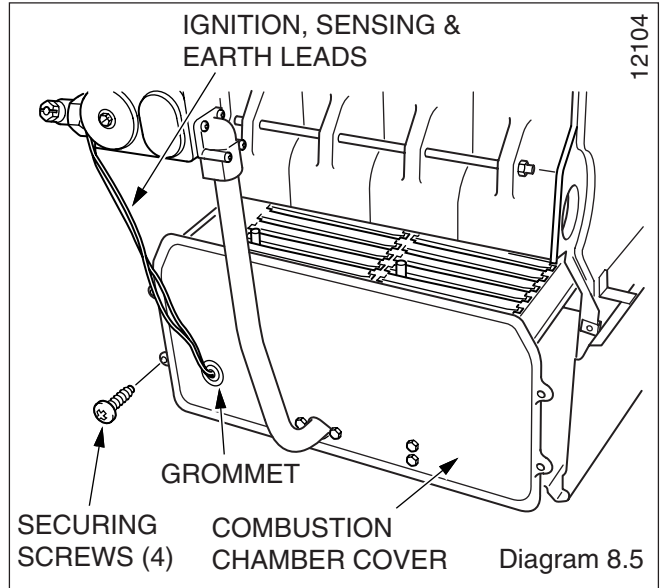

8 Servicing

8.2 Boiler Flueways

Remove flueway baffles noting that there are 3 centre and 2 side flueway baffles, see diagram 8.8.

Place a sheet of paper in the combustion chamber to catch any flue debris.

Thoroughly clean boiler flueways and fins with a suitable stiff brush.

Replace in reverse order, after completing the relevant instructions in sections 8.3 and 8.4.

8.3 Burners and Injectors

Remove the screws and nuts securing the burner support bracket to the combustion chamber cover, see diagram 8.9.

Remove the graphite coated nuts on the supply feed pipe at the rear of the burner to release the burner, see diagram 8.10.

Clean the burner. Use a vacuum cleaner or suitable stiff brush (not wire) to clean the burner thoroughly, making sure that all the burner ports are clear and unobstructed.

Check the burner injector for blockage or damage and replace if necessary, see diagram 8.11.

With the burner removed the injector can be inspected and cleaned as necessary.

For cleaning do not use a wire or sharp instrument on the hole.

If removed, use a little suitable sealant on the external thread when refitting to make sure a gas tight seal is made.

8.4 Service Checks

Inspect the ignition and sensing electrodes and clean and replace as necessary, see diagram 8.12.

Check the condition of the side and rear insulation panels in the combustion chamber.

Check the condition of the seals on the boiler access door and the combustion chamber cover.

Examine the flue hood and terminal to make sure they are clean and clear of obstructions.

Refit all parts.

Testing Flue Gases: If any doubt exists that the flue products are not exhausting correctly. Investigate by the use of a gas analyser (FGA).

Light the boiler and carry out functional tests as described in section 6.

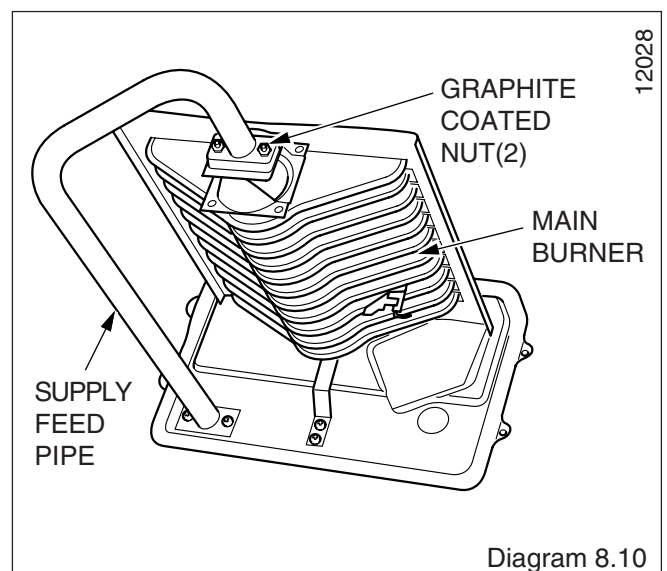
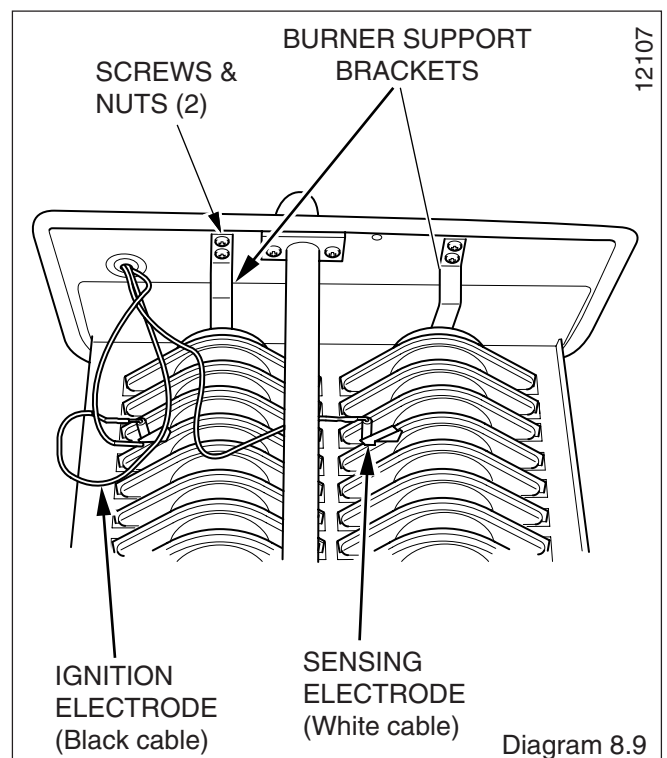
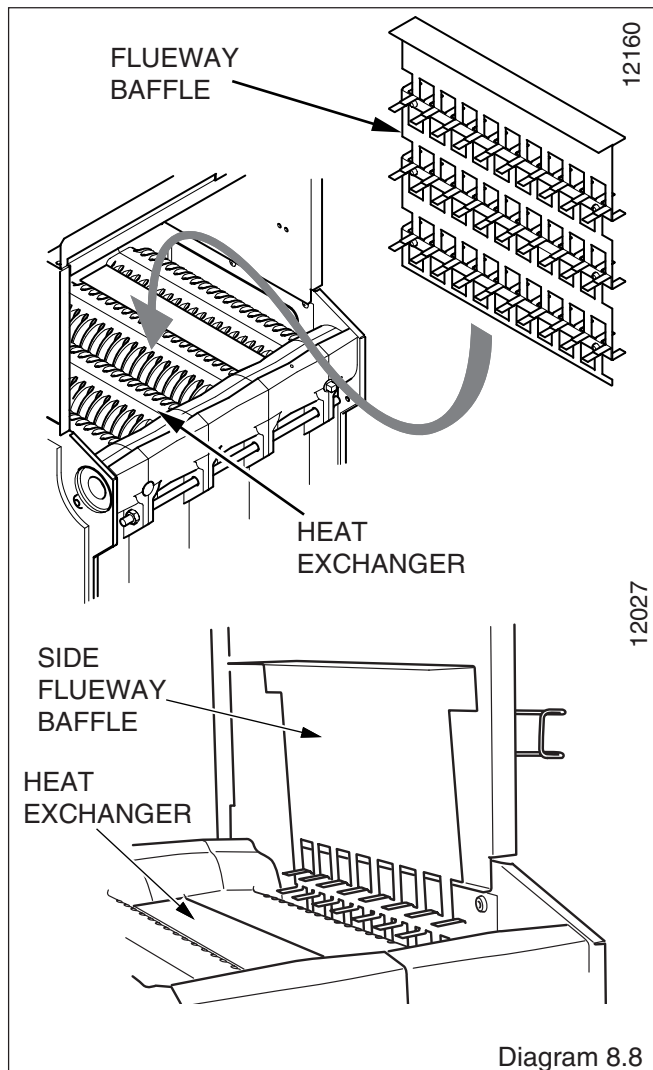

8 Servicing

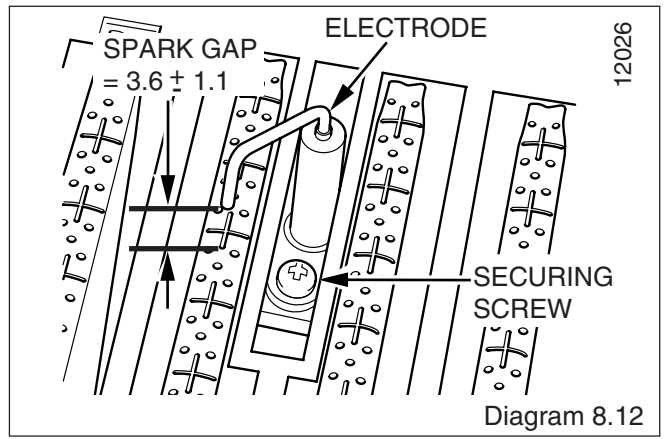
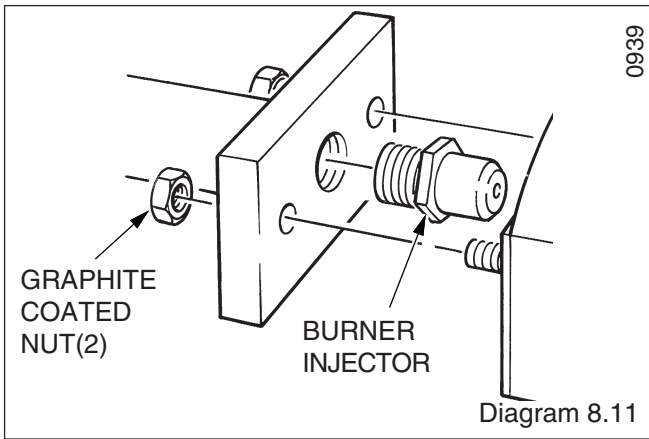

9 Fault Finding

IMPORTANT. On completion of the Fault Finding task which has required the breaking and remaking of the electrical connections, the continuity, polarity, short circuit and resistance to earth checks must be repeated using a suitable multimeter.

WARNING: The multifunctional control and fan operate on mains voltage, the terminal will be live.

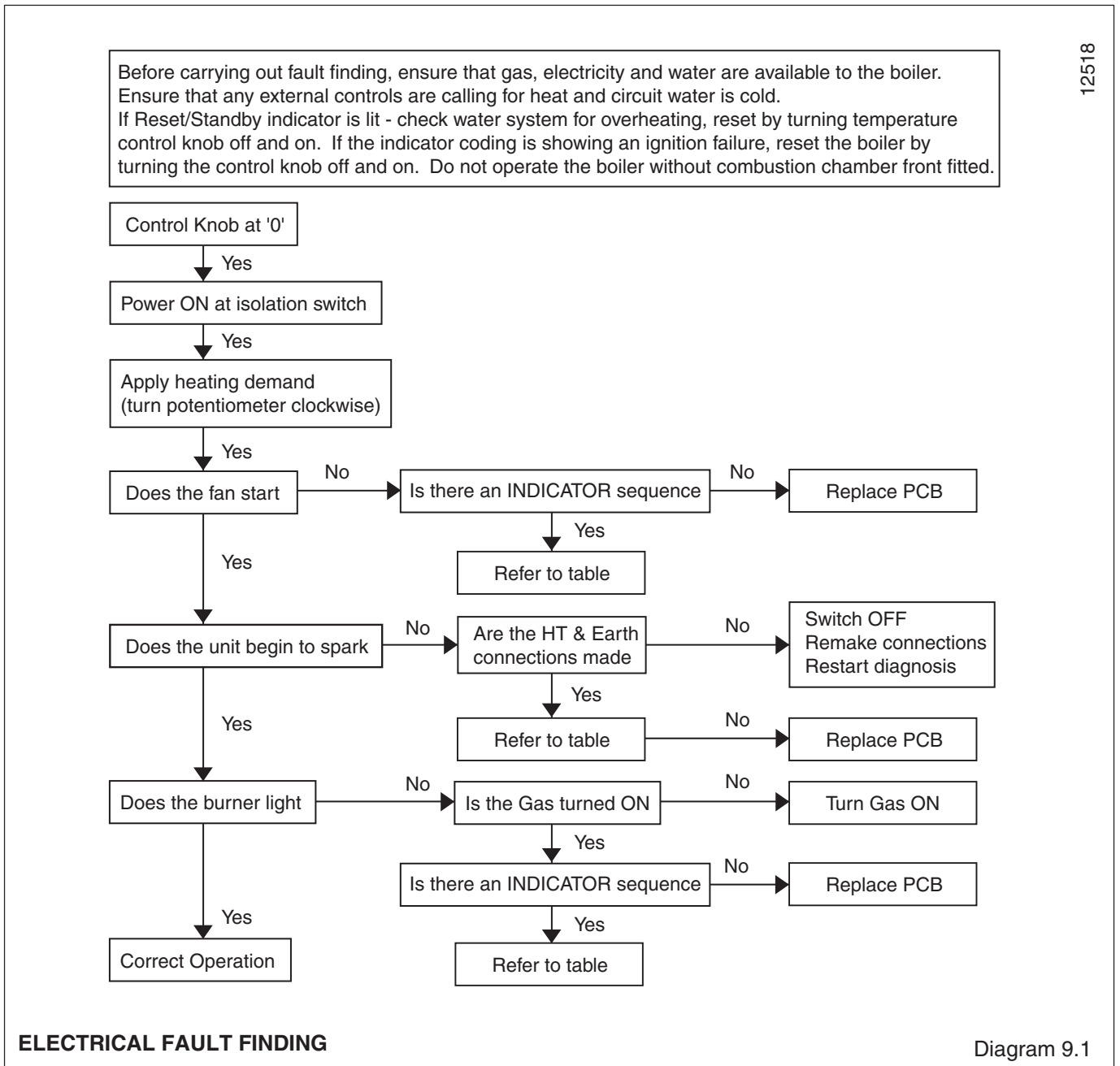

9 Fault Finding

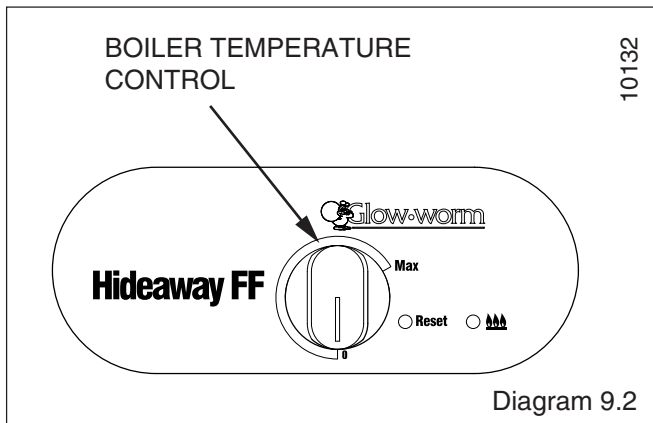

9.1 Electrical

Gain access to the control box, refer to the relevant paragraph in section 8.1, then remove the control box cover, refer to section 5.1.

Refer to: Boiler Fault Finding, see diagram 9.1, Fault Finding Wiring Diagram, see diagram 9.3, Pictorial Wiring Diagram, see diagram 9.4.

9.2 Electrical Supply Failure

Failure of the electrical supply will cause the burner to go out. Operation will normally resume on the restoration of the electrical supply.

If the burner does not relight after an electrical supply failure and the reset/standby indicator on the control panel is lit, turn the burner temperature control to "0", wait 30 seconds, then fully clockwise to "Max." see diagram 9.2.

9.3 INDICATOR Fault Coding

Refer to fault coding table below.

INDICATOR 1 (RESET)	INDICATOR 2 (BURNER LIT)	INDICATOR STATUS	CONDITION	REMARK
●	○		Non - Volatile Lockout	Reset O/H or in 'standby' mode
○	●		Burner Lit	Correct operation
⊛	●		PCB Failure	
⊛	○		Other Errors	
⊛	⊛	Simultaneous	Reversed Polarity	Transpose Live & Neutral Check Earth
⊛	⊛	Simultaneous	Lighting Sequence-Thermistor	Check connection & value
⊛	⊛	Simultaneous	Lighting Sequence-Fan/APS	Check connection & operation
⊛	⊛	Alternating	Blocking Error	
●	⊛		Software Error	
●	⊛		Ignition Lockout	

⊛	Slow Flashing (2Hz)	⊛	Fast Flashing (8Hz)
---	---------------------	---	---------------------

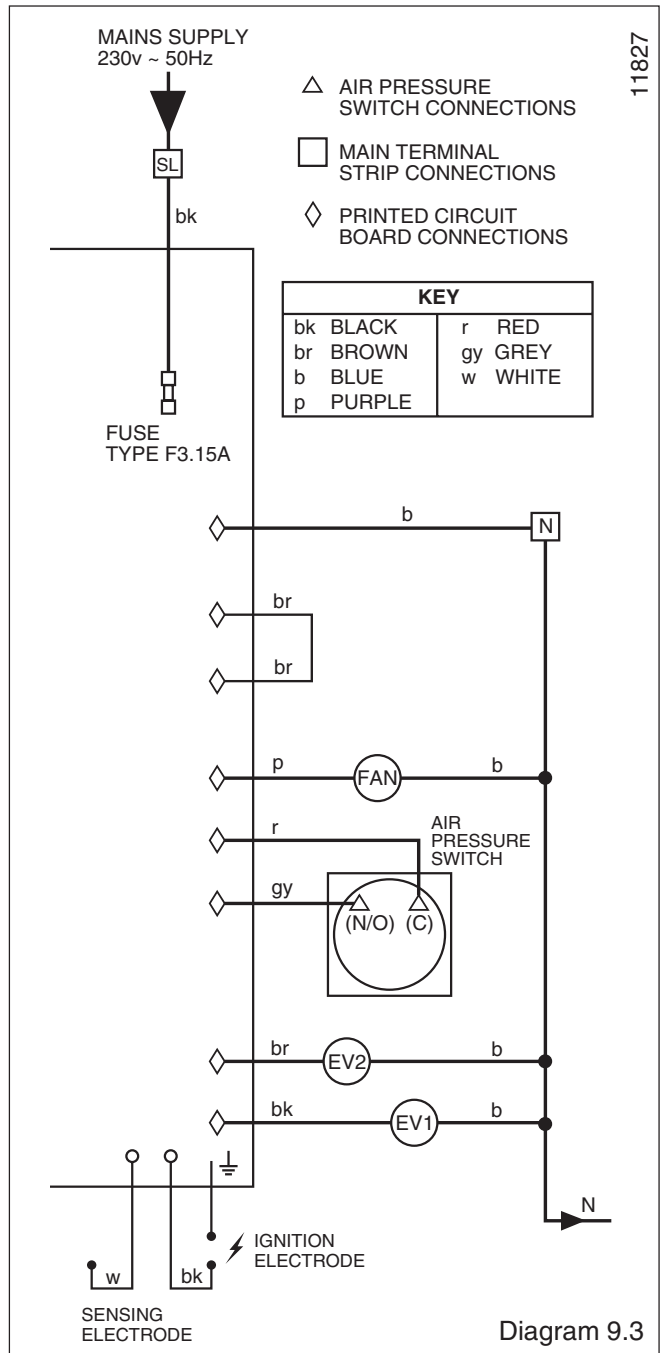

9 Fault Finding

12419

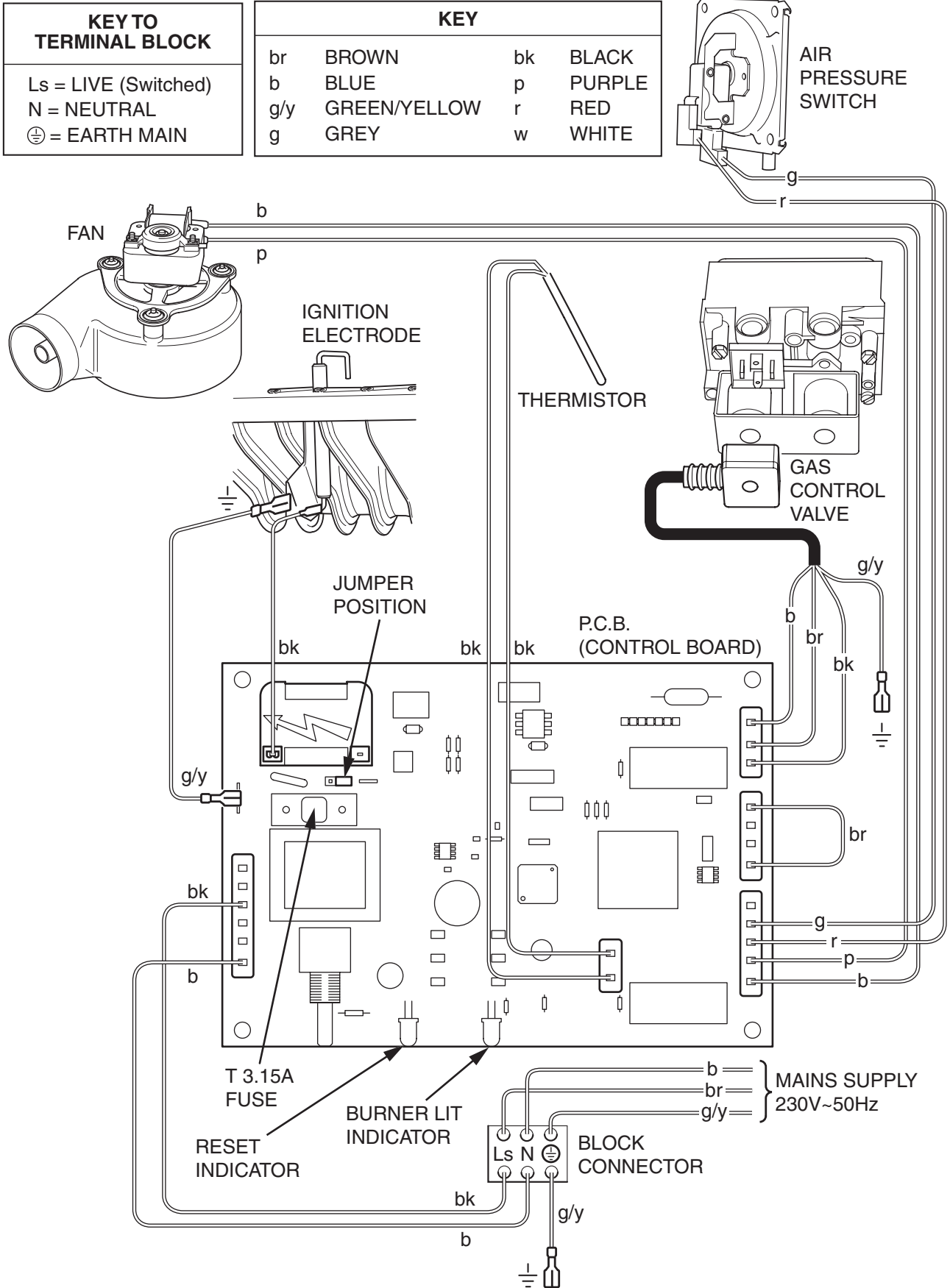

BOILER PILOT FAULT FINDING

Diagram 9.4

10 Replacement of Parts

Important notes

REMEMBER, When replacing a part on this appliance, use only spare parts that you can be assured conform to the safety and performance specification that we require. Do not use reconditioned or copy parts that have not been clearly authorised by Glow-worm

Replacement of parts must only be carried out by a **competent person**.

Before removing or replacing any parts, turn off the gas supply at the gas service cock, see diagram 8.2 and isolate the electrical supply to the appliance.

Unless stated otherwise, all parts are replaced in the reverse order to removal.

After replacing any parts always test for gas soundness and if necessary carry out functional check of controls.

10.1 Electrical Thermistor

Remove front panel to gain access, see section 6.8.

Remove control box cover by undoing the four securing screws (two on control box, two on the heat shield) and lift off, see diagram 10.1.

Remove thermistor lead from retaining clip, located on the control box support bracket, see diagram 8.3.

Release strain relief grommet securing thermistor lead at the side of control box.

Disconnect the thermistor electrical plug from the control board (P.C.B) slightly bending back the retaining latch to allow withdrawal, see diagram 10.2.

Withdraw the electrical thermistor from its phial, see diagram 10.3.

Draw the thermistor lead followed by the thermistor out though the control box case.

Re-assembly note. When fitting the thermistor make sure it is fully inserted into the phial and secured using the grommet moulded to the cable, see diagram 10.3.

10.2 Control Board (P.C.B)

Remove front panel to gain access, see section 6.8.

Remove control box lid by undoing the four securing screws (two on control box, two on the heat shield) and lift off, see diagram 10.1.

Carefully pull the boiler temperature control knob away from the P.C.B.

Disconnect the electrical plugs from the control board (PCB) slightly bending back the retaining latches to allow withdrawal, see diagram 10.2.

Disconnect the ignition, sensing and earth leads.

Carefully pull the board away from its supports bending back slightly the retaining latches.

When refitting refer to wiring diagram 9.4.

Take care when replacing the burner temperature control knob by supporting the potentiometer on the P.C.B.

NOTE: Ensure jumper is in position 'B', refer to wiring diagram 9.4.

10.3 Ignition and Sensing Electrodes

Remove front panel to gain access, see section 6.8.

Refer to the relevant paragraphs of Section 8 servicing to remove the burner from combustion chamber.

To remove the electrode, unscrew from the retaining bracket, see diagram 8.12.

Take the electrode out from below and disconnect the lead.

When removing and replacing the electrode take care not to damage it.

When refitting, check spark gap, see diagram 8.12, 9.3 and 9.4.

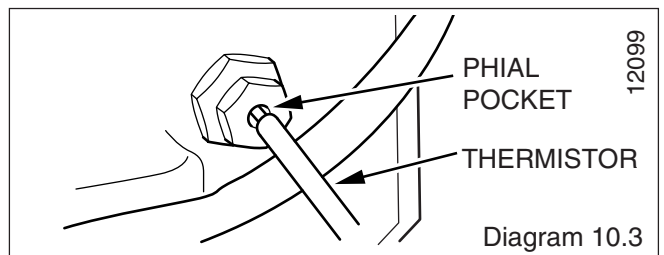
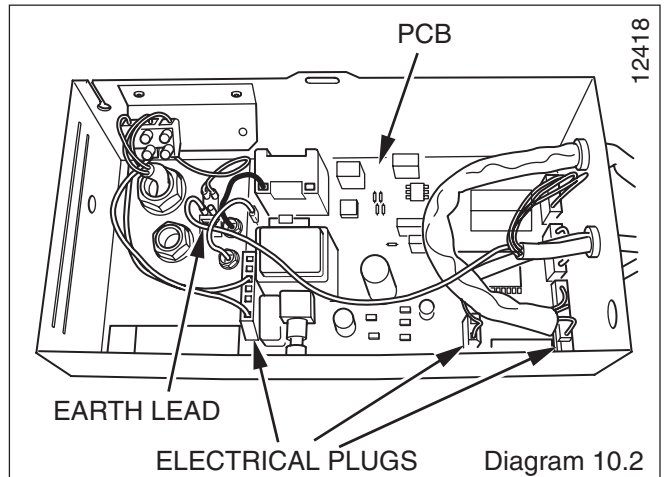
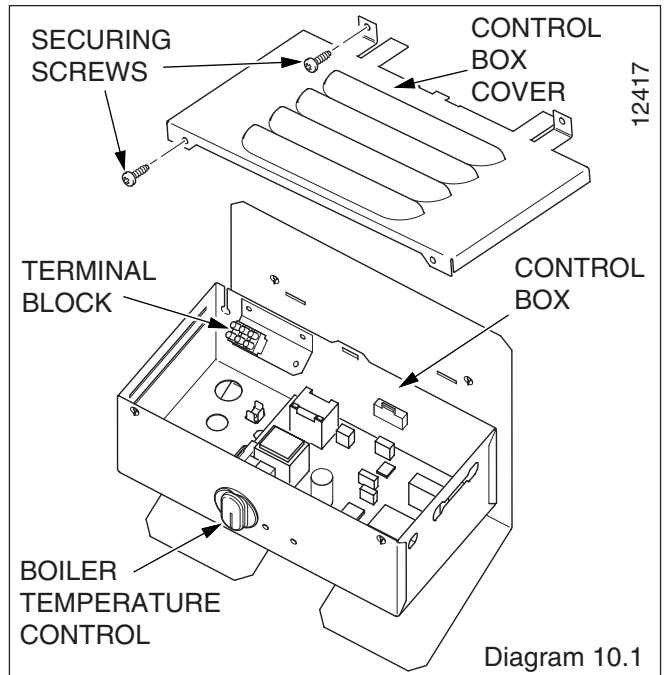

10.4 Multifunctional Control

Remove front panel to gain access, see section 6.8.

Remove the securing screw and disconnect the electrical plug, see diagram 10.4.

Disconnect the gas cock, on the left hand side.

Support the multifunctional control, remove the four screws (2 long, 2 short) from the flanged connection at the right hand side.

Remove and discard the original "O" ring from the flanged connection and fit the new "O" ring supplied, into recess, before fitting the replacement multifunctional control.

After assembly test for gas soundness and purge in accordance with the current issue of BS6891 or in IE, the current edition of I.S.813 "Domestic Gas Installations".

10 Replacement of Parts

10.5 Solenoid

Remove front panel to gain access, see section 6.8.
Remove the electrical plug from the multifunctional control and remove the securing screw and then the solenoid assembly, see diagram 10.4.

10.6 Burner

Refer to the relevant paragraphs of Section 8 servicing to remove the burner from combustion chamber.

10.7 Injector

Refer to the relevant paragraphs of Section 8 servicing to remove the burner from combustion chamber.
The injector can then be unscrewed from the manifold.
When replacing use a little jointing compound on the external thread only, to ensure a gas tight seal.

10.8 Air Pressure Switch

Refer to the relevant paragraphs of Section 8 servicing to remove the burner from combustion chamber.
Remove the air pressure tubes and electrical connections from the switch, release the securing screws and remove the switch, see diagram 10.5.
When fitting the replacement make sure that the air pressure tubes are fitted with the clear tube from the air pressure switch to the front fan connection, as shown in diagram 10.5 and the electrical connections are made as shown in wiring diagram 9.4.

10.9 Fan

Refer to the relevant paragraphs of Section 8 servicing to remove the burner from combustion chamber.
Remove the electrical connections and air pressure tubes from the fan.
NOTE: Remove the electrical connections by pulling insulation boots only.
Withdraw fan and flue hood assembly from boiler by taking hold of fan, lifting slightly up and remove, see diagram 8.7.
Undo the screw securing the fan to the flue hood and disengage fan from flue hood.
When re-assembling, make sure that the air pressure tubes are fitted as before and that the fan duct engages fully into the flue duct extension piece.
The polarity of the electrical connections is not important.

10.10 Insulation

Refer to the relevant paragraphs of Section 8 servicing to remove the burner from combustion chamber.

Sides

Undo the burner support bracket nuts and remove support bracket and insulation, see diagram 10.6.
Refit support bracket with new side insulation.

Rear

Bend forward rear insulation securing nibs, one on each side, to release insulation.
Fit new insulation and bend back securing nibs.

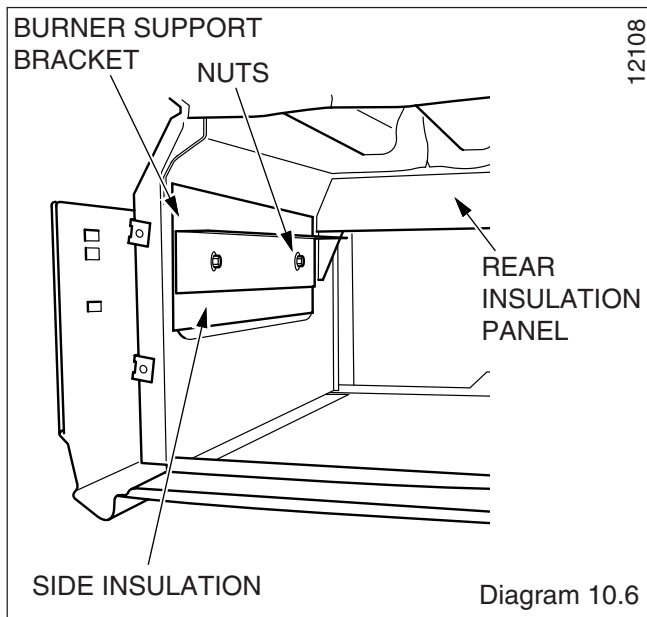
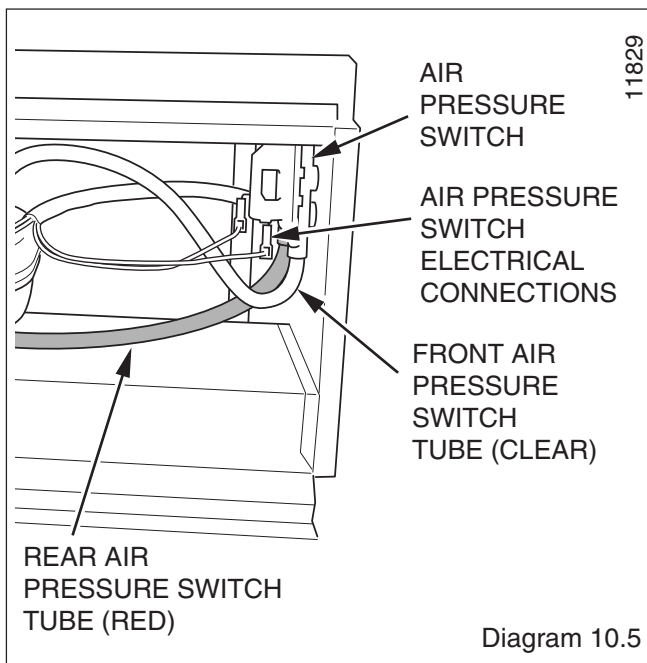
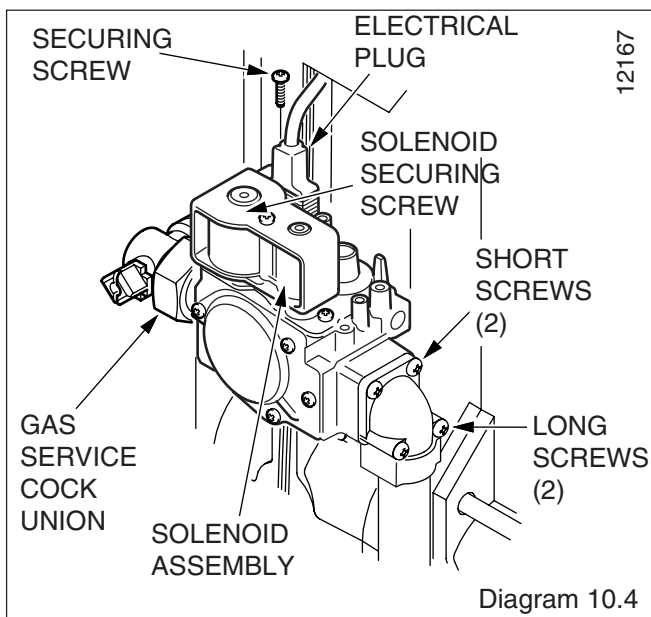

11 Spare Parts

11.1 Part Identification

The key number in diagram 11.1 and the first column of the list will help identify the spare part.

11.2 Ordering

When ordering any spare part please quote the part number and the description from the list together with the model name and serial number information from the data label.

The data label is positioned on the heat shield, see diagram 6.1.

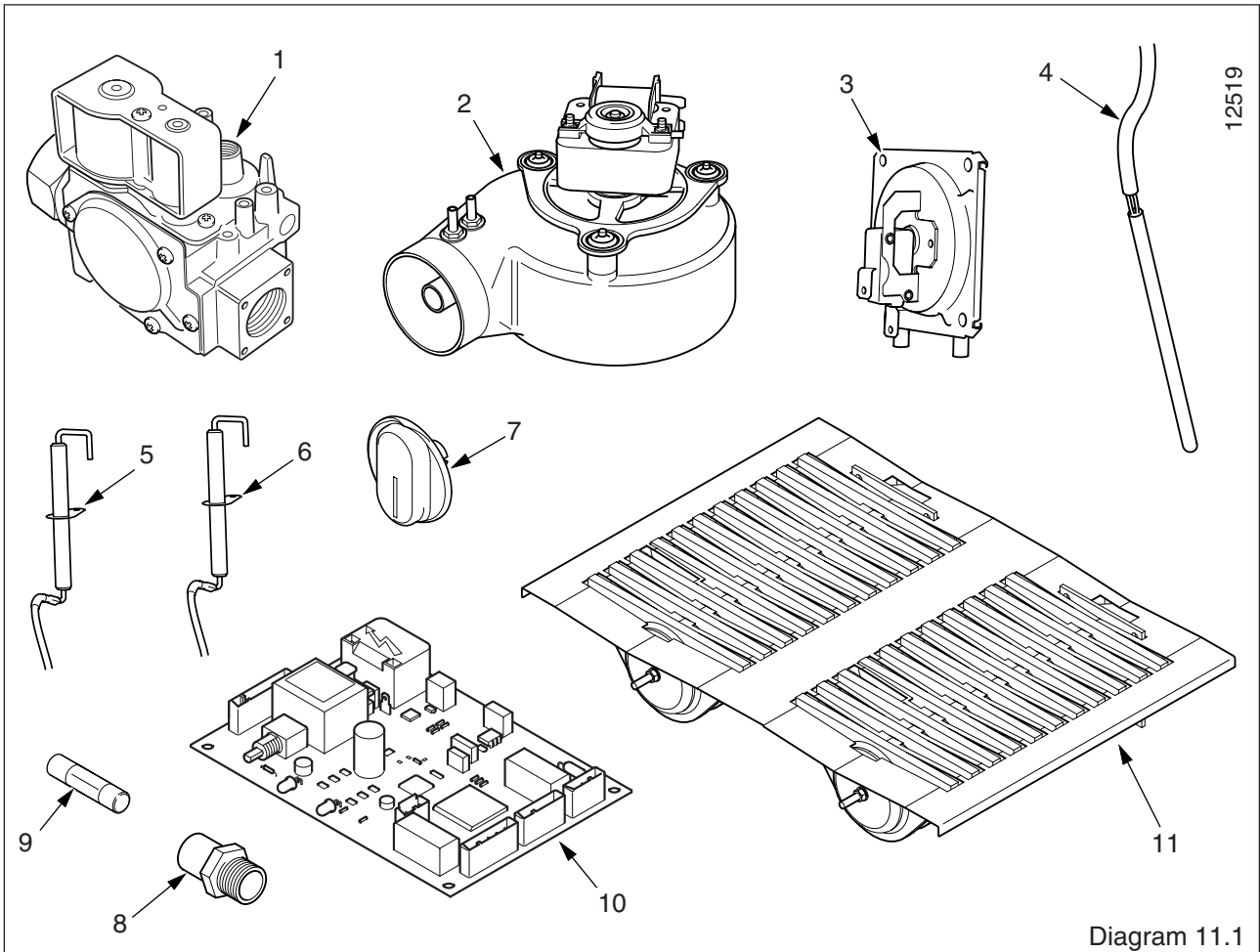

Diagram 11.1

Key No.	Part No.	Description	GC Part No.
1	2000461898	Multifunctional control	*****
2	227132	Fan	*****
3	2000227137	Air pressure switch	*****
4	2000461793	Electrical thermistor	*****
5	202635	Ignition electrode (R/H Burner)	*****
6	202635	Sensing electrode (L/H Burner)	*****
7	2000461714	Boiler temperature control knob	*****
8	2000461897	Injector 100C FF	*****
8	205746	Injector 115C FF	*****
9	202240	Fuse	*****
10	2000461896	Control board	*****
11	205657	Double Burner	*****

Because of our constant endeavour for improvement, details may vary slightly from those shown in these instructions.