

Valor Senator

Vent-free Room Heater

Model 276N - For Natural Gas

Model 276P - For LPG (Propane Gas)

INSTALLATION AND OPERATION MANUAL

Please read this manual before installing and operating your heater.

Please keep this manual for future reference.

This appliance is an unvented gas-fired heater. It uses air (oxygen) from the room in which it is installed. Provisions for adequate combustion and ventilation air must be provided.



WARNING: If the information in this manual is not followed exactly, a fire or explosion may result causing property damage, personal injury or loss of life.

- Do not store or use gasoline or other flammable vapors and liquids in the vicinity of this or any other appliance.
- **WHAT TO DO IF YOU SMELL GAS**
 - Do not try to light any appliance.
 - Do not touch any electrical switch; do not use any phone in your building.
 - Immediately call your gas supplier from a neighbor's phone. Follow the gas supplier's instructions.
 - If you cannot reach your gas supplier, call the fire department.
- Installation and service must be performed by a qualified installer, service agency or the gas supplier

LIST OF CONTENTS

	Page
Safety	3
Information	
Appliance	4
Specifications	
Installation	4 - 8
• Codes	4
• Clearances	4
• Venting	5
• Pre-installation Checks	5
• Equipment needed for Installation	5
• Pack Contents	6
• Wall Mounting	6
• Gas Connection	6
• Gas Pressure Check	7
• Fitting Cast-iron Mantle	8
• Control Operation Check	9
Lighting	10 - 11
Instructions	
• Safety Warnings	10
• Lighting	11
• To turn Off	11
Flame check	12
Cleaning	12
Servicing	13
• Replacement parts	13
• Notes for Service Engineer	13

SAFETY INFORMATION

IMPORTANT: Please read and understand this manual before installing and operating your heater. Please keep this manual for reference. It is the basis for safe and proper operation of your heater.

WARNING!

This heater must have fresh air for proper operation. If not, poor fuel combustion could result. Read the venting section in this manual.

When used without fresh air this heater may give off carbon monoxide, an odorless, poisonous gas.

Early signs of carbon monoxide poisoning resemble the flu, with headaches, dizziness and/or nausea. If you have these signs the heater may not be working properly. ***Get fresh air at once!*** Turn off the heater and have it serviced.

Some people (such as pregnant women, persons with heart or lung disease, anemia, those under the influence of alcohol, those at high altitudes) are more affected by carbon monoxide than others.

WARNING: Any change to this heater or its controls can be dangerous. Improper installation, adjustment, alteration, service or maintenance can cause injury or property damage. Refer to this manual. For assistance or additional information, consult a qualified installer, service agency or your gas supplier.

This appliance must not be installed in a bathroom or bedroom or recreational vehicle

This appliance is a room heater. It is not intended to be used for any other purpose. Do not use this appliance for hanging clothes etc. to dry or any other purpose except heating the room.

If this heater is for use with propane gas, locate propane supply tank outdoors.

Installation or repair should be performed by a qualified service person in strict accordance with local codes and ordinances. The heater should be inspected before use and at least annually by a professional service person. More frequent cleaning may be required due to excessive lint from carpeting, bedding, furnishing materials, etc. It is imperative that the control valve compartment, burners and circulating air passageways of the heater are kept clean.

Due to high temperatures, locate the heater out of traffic. Keep curtains, clothing, furniture and all other flammable materials at least 36ins from all surfaces of the heater.

Do not locate the heater in an area exposed to high drafts or winds.

Keep children and adults away from the heater surfaces which become very hot when in use. The cast-iron mantle openings, mesh guard and burners operate at high temperatures. The heater will remain hot for some time after shutdown. Allow the heater to cool before touching.

Young children should be carefully supervised when in the same room as the heater.

If the cast-iron mantle or mesh guard are removed for service or cleaning, make sure that they are put back in place before operating the heater.

Do not use this room heater if any part has been under water. Immediately call a qualified service technician to inspect the room heater and to replace any part of the control system and any gas control which has been under water.

As with any new gas burning appliance, a slight odor may be noticeable when first operated due to the newness of the components. This is harmless and will disappear after the first few hours of use.

If the heater shuts off automatically, provide fresh outside air before attempting to relight.

For your safety, the heater has a sensor which detects a lack of oxygen and will shut off the appliance if there is not enough fresh air for proper combustion. If the heater keeps shutting off get advice from your installer.

Do not use this heater for burning trash. Never place any garbage or other material on top of the log or in the flames.

APPLIANCE SPECIFICATIONS

FEATURE		MODEL	
		276N	276P
GAS		NATURAL	PROPANE
INLET PRESSURE (Ins w.c.)	MAX	10.5	14
	MIN ¹	5	11
MANIFOLD PRESSURE (In w.c.)	MAX	4.2	9.7
	MIN	3.8	9.3
INPUT MAX (Btu/h)		25,000	28,000
HEIGHT (Ins.)		26 ³ / ₈ "	
WIDTH (Ins.)		25	
DEPTH (Ins.)		8 ³ / ₈ "	
BLOWER ACCESSORY ²		VF171 or VFT171	

Notes:

- For purposes of input adjustment.
- Contact your dealer for details of the blower accessory.
- WARNING: Do not use a blower insert, heat exchanger insert or other accessory not approved for use with this heater**

This appliance is design certified for use in the USA by International Approval Services to ANS Z21.11.2a - 1997 (Unvented gas fired room heaters).

INSTALLATION

CODES

Installation requirements vary with the locality. The installation must conform with local codes or, in the absence of local codes, with the latest edition of the National Fuel Gas Code ANSI Z223.1. This appliance may be installed in an aftermarket manufactured (mobile) home where not prohibited by state or local codes.

Aftermarket: Completion of sale, not for purpose of resale, from the manufacturer.

This appliance is only for use with the type of gas indicated on the rating plate. This appliance is not convertible for use with other gases.

CLEARANCES

The minimum clearances to combustible surfaces are shown in figure 1.

Allow sufficient clearances for comfortable operation of the controls and easy access for cleaning and servicing.

If the appliance is intended to be installed on carpeting, tile or other combustible flooring other than wood, it must be installed on a metal or wood panel extending the full width and depth of the appliance.

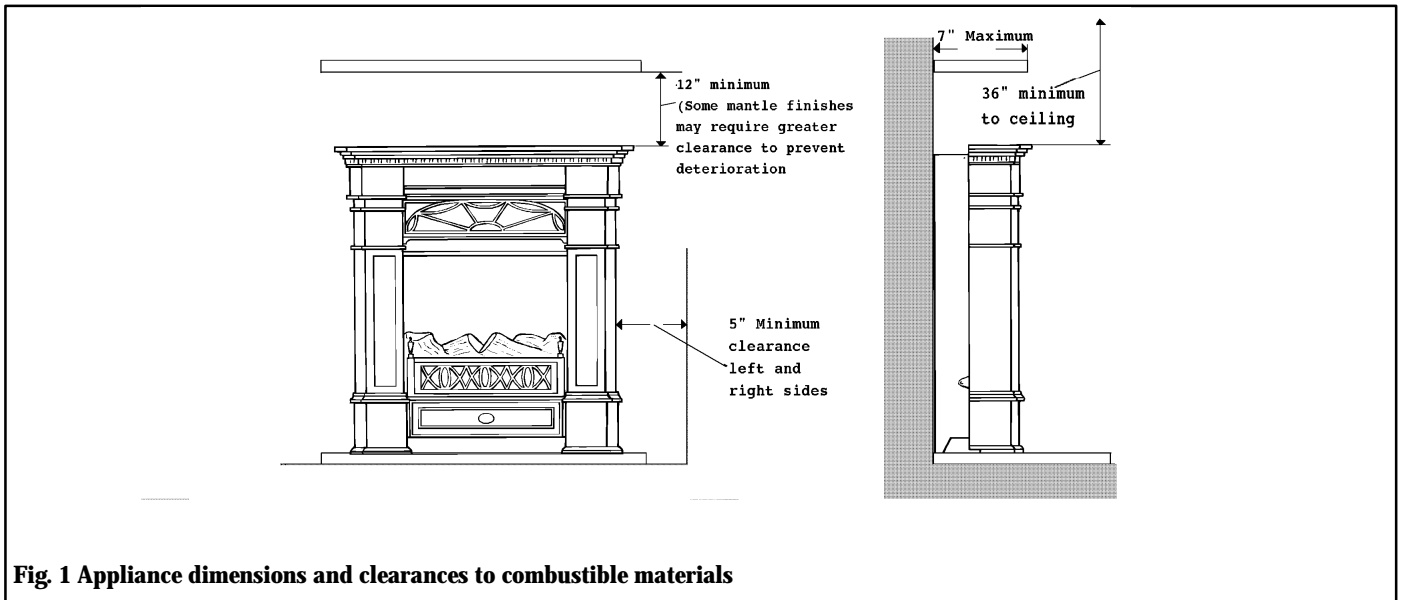

Fig. 1 Appliance dimensions and clearances to combustible materials

VENTING

This heater shall not be installed in a confined space unless provisions are provided for adequate combustion and ventilation air.

The National Fuel Gas Code defines a confined space as a space whose volume is less than 50 cubic feet per 1,000 Btu per hour (4.8m³) of the aggregate input rating of all appliances installed in that space and an unconfined space as a space whose volume is not less than 50 cubic feet per 1,000 Btu per hour (4.8m³) of the aggregate input rating of all appliances installed in that space. Rooms communicating directly with the space in which the appliances are installed, through openings not furnished with doors, are considered a part of the unconfined space.

If there are no other appliances in the area, the minimum volume which can be defined as an unconfined space for the appliances covered by this manual is as follows:-

<u>Model</u>	<u>Minimum unconfined space (cu. ft)</u>
276N	1250
276P	1400

If there are other appliances in the area, add 50 cu. ft. to the above figure for every 1,000Btu/h of total maximum input rating of these appliances.

Do not include any direct vent appliances in the calculation. Direct vent appliances draw air from and exhaust combustion products directly to the outdoors.

WARNING: If the area in which the heater may be operated is smaller than that defined as an unconfined space, provide adequate combustion and ventilation by one of the methods described in the National Fuel Gas Code, ANSI Z223.1, 1992, Section 5.3.

PRE-INSTALLATION CHECKS

Check gas type. Use only with the gas type indicated on the appliance rating label. If the gas type indicated on this label is not your type of gas supply **do not install!** Contact your dealer for the proper model.

Check gas line pressure. Check that the pressure is no greater than the maximum shown in appliance specification table. This will prevent damage to the regulator fitted to the appliance. Propane appliances require an external regulator to reduce the supply tank pressure to the maximum of 14 inches w.c. This is in addition to the regulator fitted to the appliance.

WARNING: Connecting directly to an unregulated Propane tank can cause an explosion!

EQUIPMENT NEEDED FOR INSTALLATION (not included with appliance)

- Pipe sealant resistant to the gas used and all its constituents. Note that natural gas can contain some LP gas during peak supply periods.
- Piping. We recommend using only new black iron or steel pipes. Copper tubing may be acceptable - check local codes. If copper tubing is used, it must be internally tinned or equivalently treated to resist corrosion by sulfur compounds.
- Manual shut-off valve.
- Union, drip leg and 1/8" NPT plugged tap for test gauge connection.
- Pipe wrenches.
- Pressure test gauge equipment.

UNPACKING

The heater is supplied in two packs.

Pack 1 Contains the cast-iron mantle fully assembled.

Pack 2 Contains

- 1 Heater unit fitted with elbow gas inlet connector
- 1 Straight gas inlet connector alternative
- 1 Top connector plate - heater to wall
- 2 Connecting brackets for cast-iron mantle.
- 2 Machine screws for mantle securing
- 2 Thread cutting screws for fixing top connector to heater top
- 2 Screws for wall fixing
- 2 Wall anchors.

Check the contents for shipping damage. If damaged, inform your dealer. **Do not install! Damage causing a safety hazard may have occurred.**

WALL MOUNTING

1. Place the heater unit against the wall in the position in which it is intended to be installed.
2. Mark the mounting hole positions through the heater back on to the wall (See figure 2).

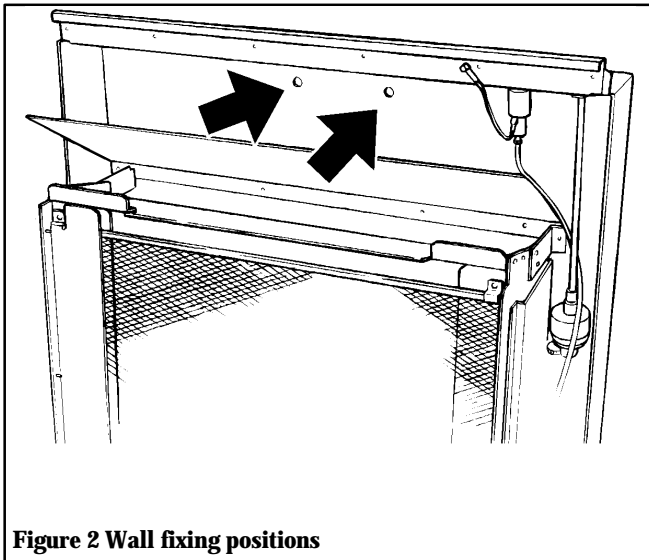

Figure 2 Wall fixing positions

3. Drill the wall at the marked centers. The hole size will depend on the type of wall and fixing method. The heater is supplied with #8 woodscrews and anchors suitable for solid and plasterboard walls. These anchors require a 1/4" hole size.
4. Secure the top connector plate to the wall using the woodscrews (and anchors where necessary). See figure 3.

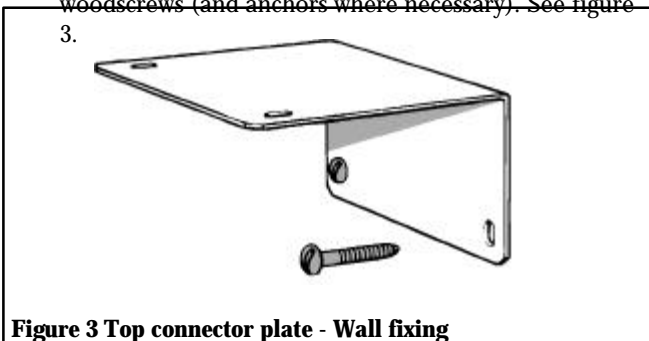

Figure 3 Top connector plate - Wall fixing

5. Place the heater unit back in position. Attach the heater top to the connector plate with the two thread cutting screws supplied.

If blower accessory VF171 or VFT171 is to be fitted

Connect blower in accordance with the instructions supplied with the accessory. Attach the connector plate through the two holes nearest the **back** of the heater (See figure 4).

If blower accessory VF171 or VFT171 is not to be fitted

Attach the connector plate through the two holes nearest the **front** of the heater (See figure 4).

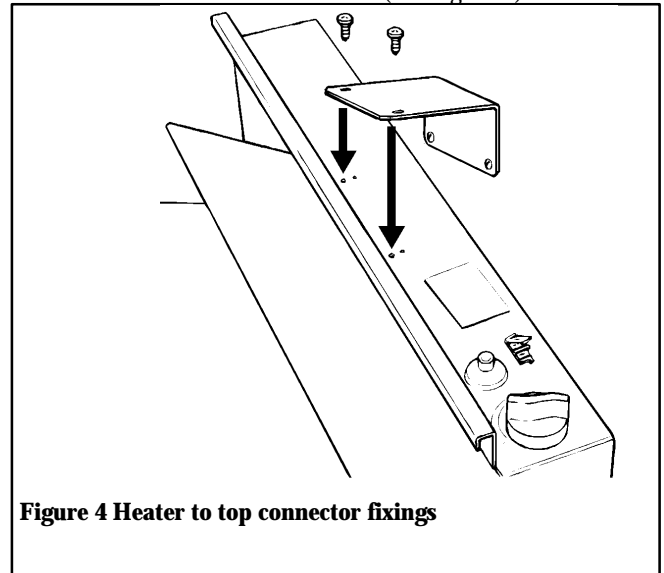

Figure 4 Heater to top connector fixings

GAS CONNECTION

Gas connection is 1/2" NPT near the rear right corner.

The appliance is supplied fitted with an elbow connector. This connector can be rotated to allow supply pipe connection from the left or right side or from below the heater. For rear connection, the pack includes an alternative straight connector to replace the elbow.

The gas supply line must be sized and installed to provide a supply of gas sufficient to meet the maximum demand of the appliance (see specification table) without undue loss of pressure.

Always use pipe compound. Apply compound lightly to the male threads to ensure excess does not enter gas lines. The compound must be resistant to LP gas.

A plugged 1/8in. NPT tapping should be installed upstream of the connection to the appliance. The tapping should be accessible for test gauge connection.

We also recommend the installation of a sediment trap upstream of the appliance. This will trap any solid or liquid contaminants which may otherwise enter the heater causing poor performance.

Appliance shut-off valve (Figure 5)

This heater incorporates a shut-off valve. The valve is located at the bottom front corner, at the upstream end of the pipe running to the thermostat.

The valve is supplied in the open position.

To shut the valve:

- 1) Remove the screw cap and sealing washer by turning counterclockwise
- 2) Turn the slotted plug clockwise as far in as it will go.
- 3) Replace the screw cap and washer.

To open the valve :

- 1) Remove the screw cap and sealing washer by turning counterclockwise.
- 2) Turn the slotted plug counterclockwise until it is almost level with the outer face of the valve body.
- 3) Make sure that the sealing washer is over the screw cap. Engage the screw cap bar into the slot in the plug.
- 4) Turn the screw cap clockwise so that it turns the plug and then screws into the valve body.
- 5) Keep turning until the cap is fully sealed. The plug inside

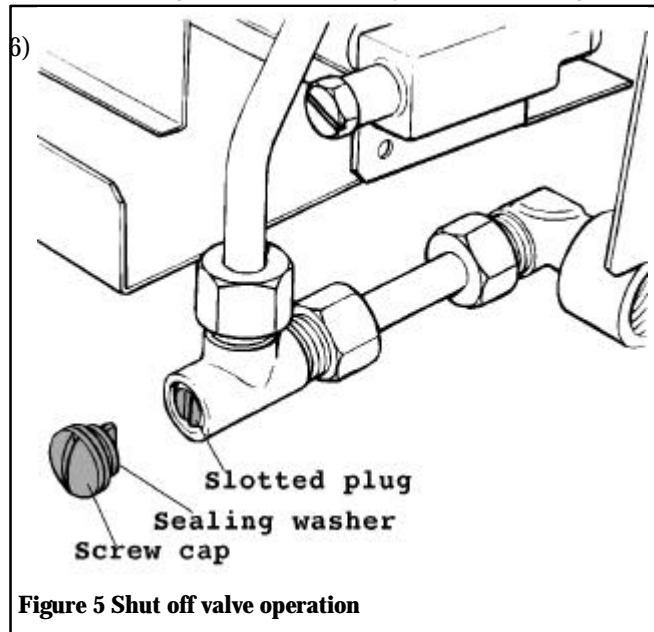

Figure 5 Shut off valve operation

Check for gas leaks

Always check for gas leaks after installation or servicing. When testing for leaks:-

1. Make sure that the heater control is at the “off” position.
2. Open the manual shutoff valve.
3. Test for leaks by applying a liquid detergent to all joints. Bubbles forming indicate a leak.

Never use an open flame to check for a leak!

4. Correct any leak detected immediately.

GAS PRESSURE CHECK

The supply pressure to the heater must be within the inlet pressure figures stated in the specification table.

Pressure testing supply line

The appliance and its individual shutoff valve must be disconnected from the gas supply piping system during any pressure testing of that system at test pressures in excess of ½ psig (3.5kPa).

The appliance must be isolated from the gas supply piping system by closing its individual manual shutoff valve during any pressure testing of the gas supply piping system at test pressures equal to or less than ½ psig (3.5kPa).

Pressure testing burner manifold

The burner manifold pressure is controlled by a regulator within the thermostat unit. The manifold pressure must be within the figures stated in the specification table. The pressure test tapping point is at the right side of the burner unit (see figure 6).

Check pressure as follows

- 1) Remove the hexagonal screw from the tapping point.
- 2) Fit a manometer to the tapping.
- 3) Turn control to Pilot. Press igniter button to light pilot then turn to “High”.
- 4) The manifold pressure should be within the limits shown in the specification table.
- 5) If pressure is outside the limits, adjust by turning the regulator screw located on the front face of the thermostat (see figure 6).
- 6) Turn the gas off, remove the manometer and refit the tapping screw

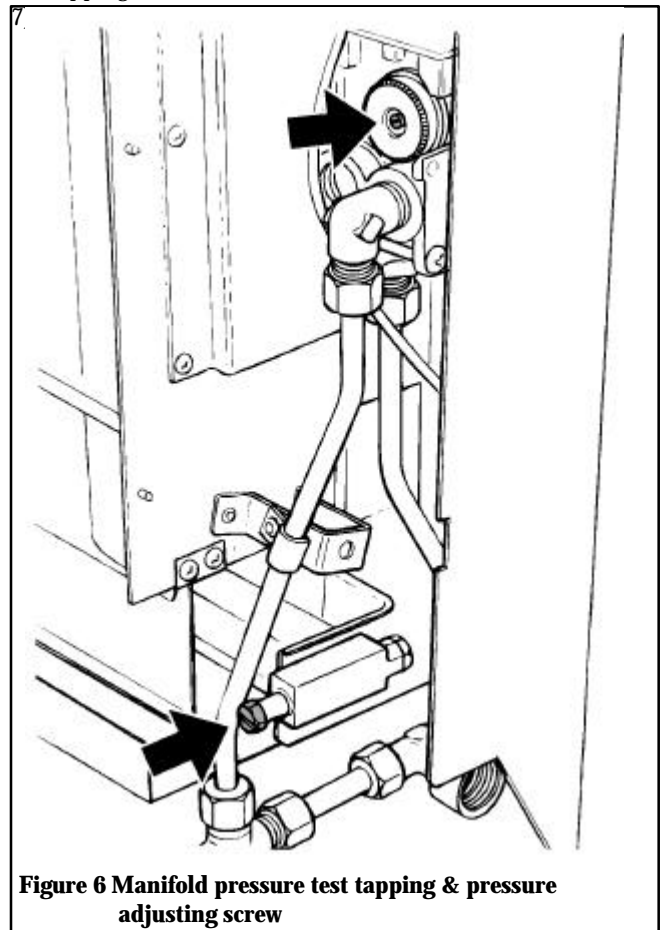
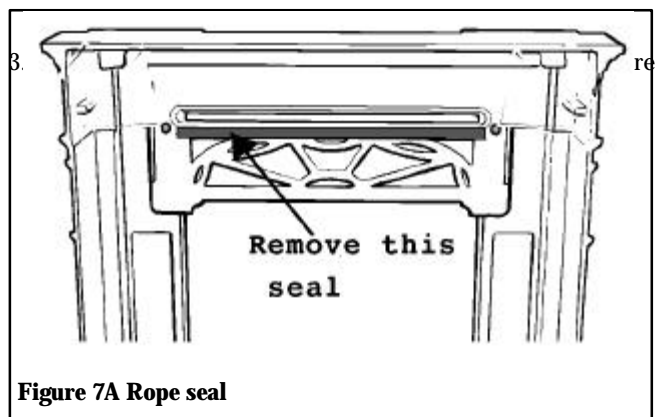
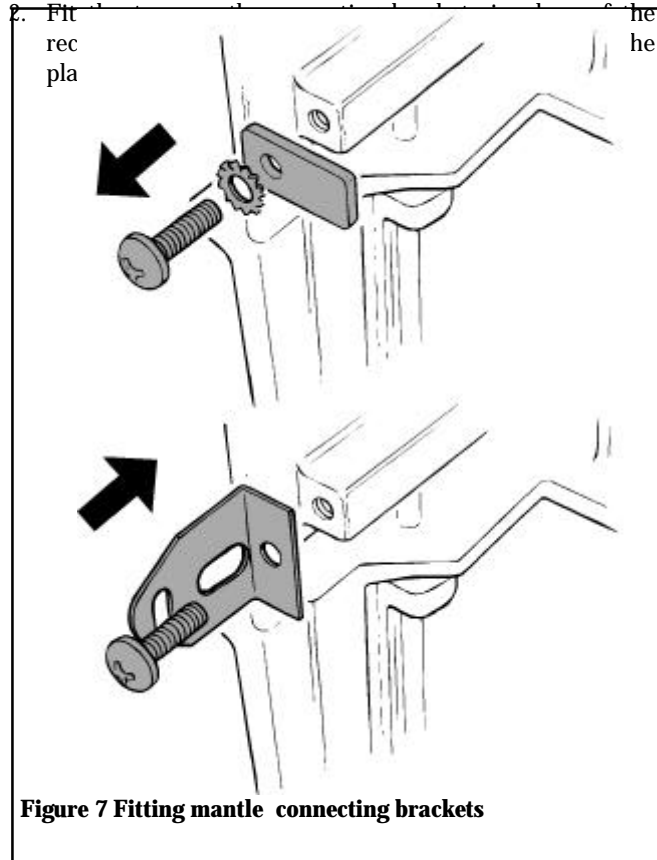

Figure 6 Manifold pressure test tapping & pressure adjusting screw

FITTING CAST-IRON MANTLE

1. Remove the two rectangular plates at back of the casting near the bottom (see figure 7). The plates and washers will not be needed for this appliance but **save the screws**.



4. Lift the mantle. Hook the top of the mantle over the heater unit so that the two flanges at back of the mantle top are behind the channel at top of the heater unit (see figure 8). Lower the mantle as far as possible to fully engage over the heater.

5. Swing the bottom of the mantle back. The mantle connecting brackets should be outside the heater sides. Align the holes in the brackets with the threaded holes in the heater sides. Fit the two machine screws supplied and tighten. See figure 9.

Note If the mantle sides are not square with the top, they can be realigned by loosening the hexagonal bolts connecting the cross grills (See figure 10).

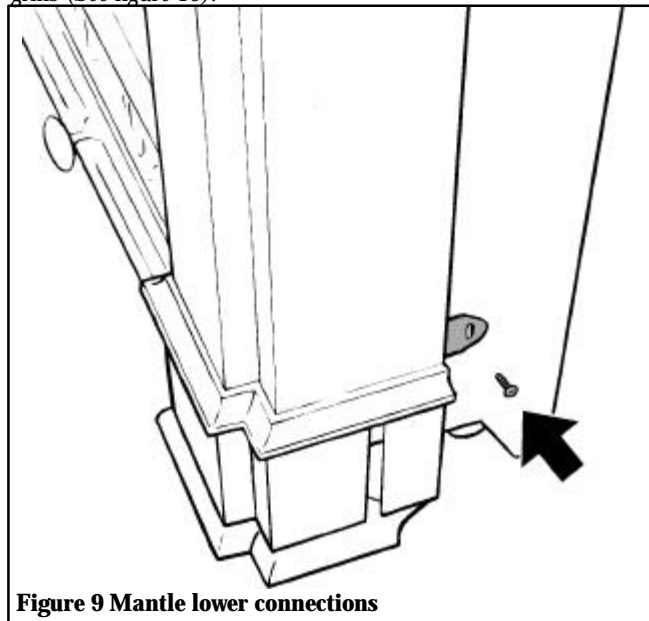
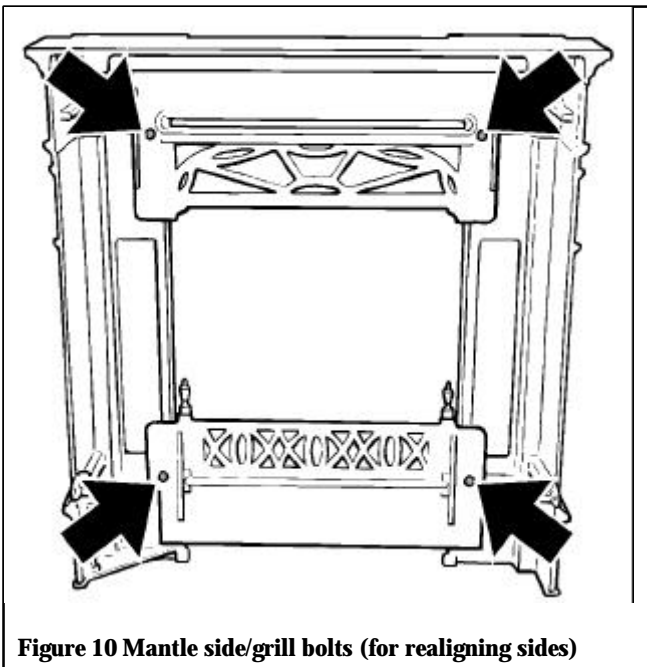

Figure 9 Mantle lower connections

CONTROL OPERATION CHECK

Check the pilot ignition and thermostat control operation -
See Lighting instructions.



FOR YOUR SAFETY READ BEFORE LIGHTING

WARNING: If you do not follow these instructions exactly, a fire or explosion may result causing property damage, personal injury or loss of life.

- A. This appliance has a pilot which must be lighted by hand. When lighting the pilot, follow these instructions exactly.**
- B. BEFORE LIGHTING smell all round the appliance area for gas. Be sure to smell next to the floor because some gas is heavier than air and will settle on the floor.**



WHAT TO DO IF YOU SMELL GAS

- **Do not try to light any appliance.**
- **Do not touch any electric switch; do not use any phone in your building.**
- **Immediately call your gas supplier from a neighbor's phone. Follow the gas supplier's instructions.**
- **If you cannot reach your gas supplier, call the fire department.**
- C. Use only your hand to push in or turn the gas control knob. Never use tools. If the knob will not push in or turn by hand, don't try to repair it, call a qualified service technician. Force or attempted repair may result in a fire or explosion.**
- D. Do not use this appliance if any part has been under water. Immediately call a qualified service technician to inspect the appliance and to replace any part of the control system and any gas control which has been under water.**

LIGHTING INSTRUCTIONS

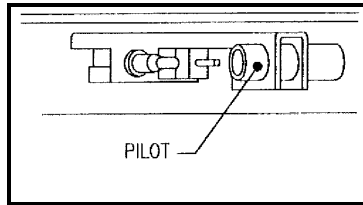
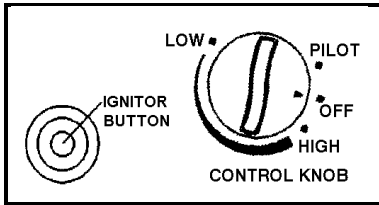
1. **STOP! Read the safety information on previous page.**



2. Turn the control knob on right side of heater clockwise to  "OFF" position.
3. Wait five (5) minutes to clear out any gas. Then smell for gas, including near the floor. If you smell gas, **STOP! Follow "B" in the safety information on previous page.** If you don't smell gas, go to the next step.
4. Find the pilot. It is in the center below the log.
5. Turn the control knob counterclockwise to  the "PILOT" position. Press in the control knob for five (5) seconds.
6. With the control knob pressed in, push down and release the ignitor button. This will light the pilot. If necessary, push down and release the ignitor button several times until the pilot lights. If the pilot does not light at all during several attempts, try lighting with a long match as described below.
7. Keep the control knob pressed in for about ten(10) seconds then release the knob. The pilot should remain alight
 - If the pilot lights but will not remain alight after several attempts, turn the gas control knob to "OFF" and call your service technician or gas supplier.
8. Turn the control knob counterclockwise to  your desired heating level. The main burner should light. Set the knob to any level between "LOW" and "HIGH".

Match lighting: Apply a long match to the pilot while the control knob is depressed and at the "PILOT" position.

- If control knobs do not pop up when released after being depressed, stop and immediately call your service technician or gas supplier.

TO TURN OFF GAS TO APPLIANCE

Shutting off completely: Turn control clockwise to  OFF.

Leaving pilot on: Turn control clockwise  to PILOT.

FLAME CHECK

Make a visual check of the pilot and main burners periodically.

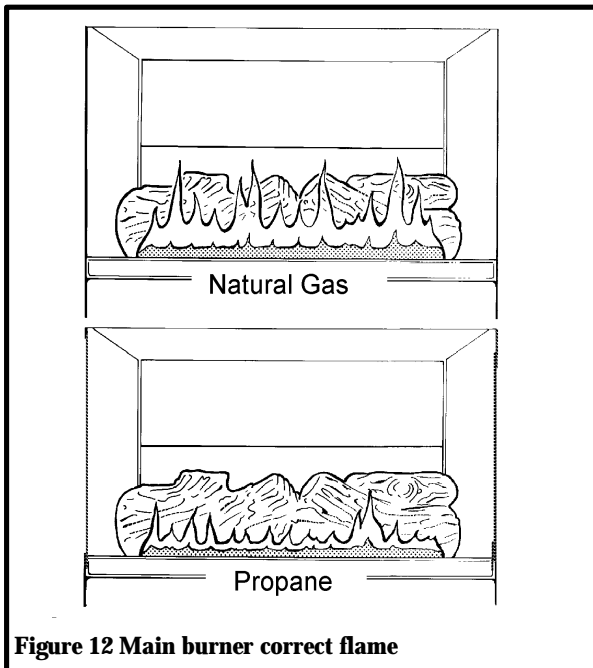
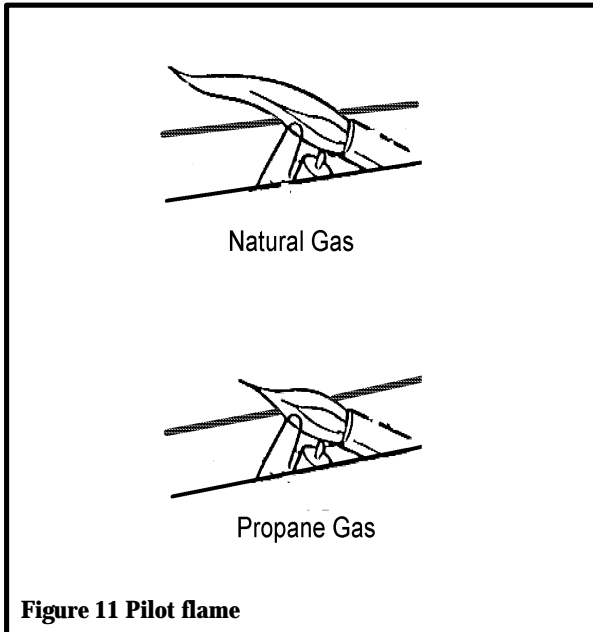

Pilot flame

The pilot flame should always be alight when the heater is in operation. The pilot flame should appear as shown in figure 11.

Main burner flame

Check the main burner at "high" control setting. After operating for approximately 15 minutes, the main flames should appear as shown in figure 12.

Natural gas models - The flames should be approximately 2 inches above the log.

Propane models - The flames should be between half way up the log and the top of the log.

CLEANING

The gas should be turned off and the heater allowed to cool fully before attempting any cleaning.

The case should only need occasional dusting with a soft cloth or wiping using a mild soap. Do not use abrasive cleaners.

Burner cleaning If the flames do not have the correct appearance or the burners do not light properly, the burner orifices may need cleaning. **The burners should be cleaned by a qualified technician.**

To clean the burners

1) Remove the two screws attaching the mantle side brackets

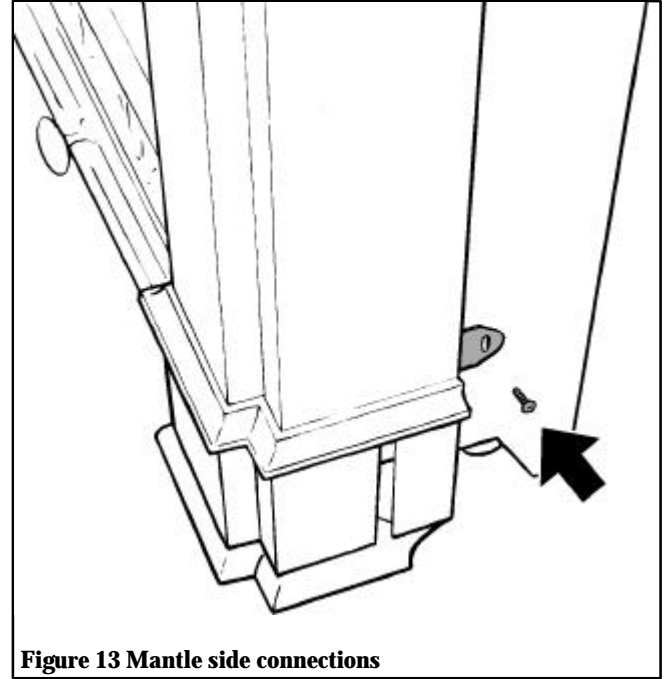

2) Swing the bottom of the mantle slightly forward and lift it

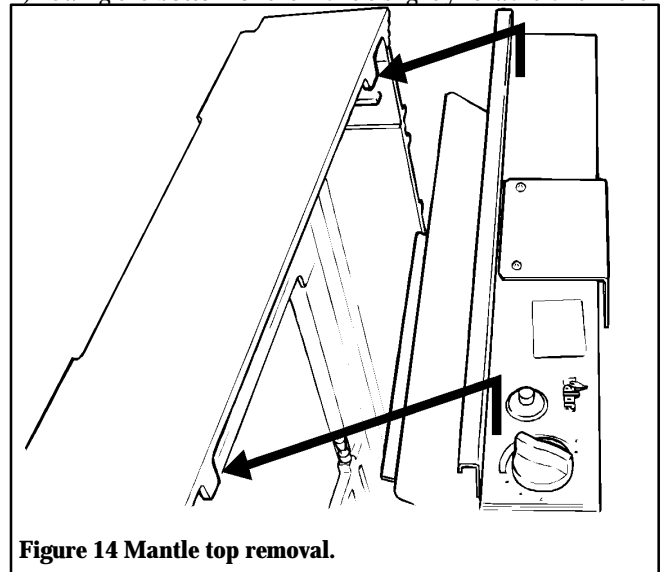

Please always quote Appliance model and serial number on all communications.

Refer to the separate repair parts list supplied with this heater for repair parts.

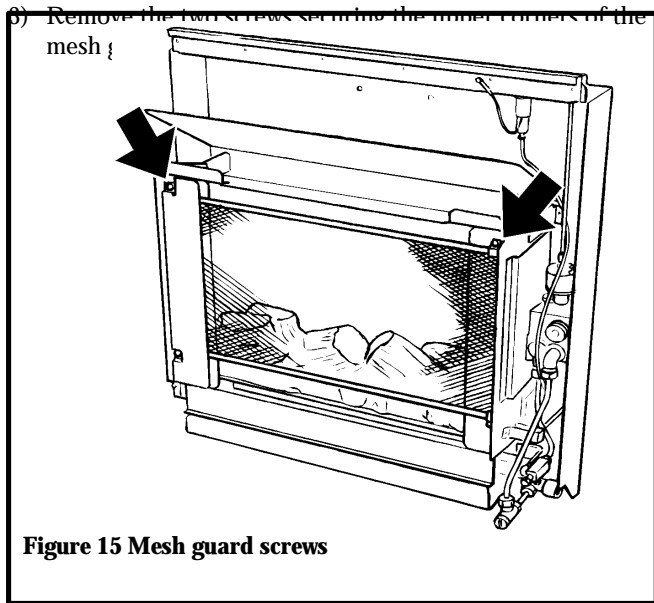

- 4) slide the guard up and remove it from the heater.
- 5) Remove dust and loose particles from the log and burner using a vacuum cleaner.
- 6) Replace the guard and mantle. Make sure the guard is replaced the correct way up. If it is fitted upside down, the mesh will considerably reduce the visibility of the burner flames (See figure 16).
- 7) If the heater still does not operate correctly, get expert advice.

SERVICING

This appliance should have a regular 12 monthly inspection and service. The inspection should include

- Checking burner rail aeration inlets, gas inlet and exit orifices.
- Checking pilot orifice, thermocouple tip condition and pilot unit performance.
- Checking for any log degradation.

Repair and replacement work should only be undertaken by a qualified service person.

Please always quote Appliance model and serial number when requesting work.

REPLACEMENT PARTS

Contact your dealer for replacement parts.

If you are unable to obtain the part from your dealer, contact:-

GASM,

Post Office Box 604

Portland, TN 37148

Phone (Toll free): 1-800-892-8136

Fax (Toll free): 1-800-872-8062

NOTES FOR SERVICE ENGINEER

1. If the thermostat is removed and refitted or replaced, make sure that there is an air space between the inner side of the thermostat block and the fire box channel plate. This space is maintained either by the screwed bushes projecting through the channel plate or by star washers spacing the thermostat away from the plate. The air space is required to keep the thermostat block temperature within its safe working limit. If star washers were fitted, make sure that they are replaced. Don't use solid washers. Star washers are used to minimize the heat transfer area.
2. If the mesh guard is removed, make sure it is replaced the correct way up. If it is fitted upside down, the mesh will considerably reduce the visibility of the burner flames (See figure 16).
3. The top surface of the stainless steel channel below the mesh grill will color with use. This is quite normal. The channel will not need to be changed. The channel surface is only visible when the cast-iron mantle is removed.

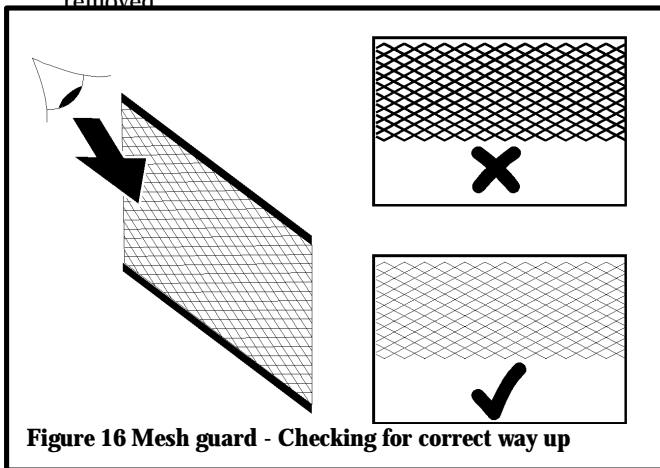

Figure 16 Mesh guard - Checking for correct way up

LIMITED WARRANTY POLICY

Valor warrants this appliance and all components for a period of three years from date of purchase against defects in material or workmanship. The purchaser's exclusive remedy against Valor for any breach of warranty shall be, at Valor's option, the repair, replacement, or return for credit of the appliance. This warranty does not extend to (i) appliances damaged by accident, neglect, misuse, abuse, alteration, negligence of others, including the installation thereof by unqualified installers, or (ii) the costs of removal, reinstallation or transportation of defective parts on the appliance unit. This warranty only applies to the original consumer purchaser.

THIS WARRANTY IS EXPRESSLY IN LIEU OF ALL OTHER WARRANTIES, EXPRESSED OR IMPLIED, INCLUDING THE WARRANTIES OF MERCHANTABILITY OR FITNESS FOR A PARTICULAR PURPOSE AND ALL OTHER OBLIGATIONS OR LIABILITIES. VALOR DOES NOT ASSUME, NOR HAS IT AUTHORIZED ANY PERSON INCLUDING ITS SALES REPRESENTATIVES TO ASSUME FOR IT, ANY OTHER OBLIGATION OR LIABILITY IN CONNECTION WITH THE SALE OR USE OF THIS APPLIANCE. IN NO EVENT WILL VALOR BE LIABLE TO THE PURCHASER OR ANY OTHER PERSON FOR DIRECT OR INDIRECT, CONSEQUENTIAL, INCIDENTAL OR SPECIAL DAMAGES, OTHER THAN AS SPECIFIED ABOVE.

The appliance must be installed by a qualified installer in accordance with the instructions furnished with the appliance. Any defective appliances or parts of the defective appliances covered by this warranty should be returned at your expense to the dealer from where the product was purchased or an authorized service agent. Any products presented for warranty repair must be accompanied by the sales invoice evidencing proof of purchase and date of purchase.

Some states do not allow the exclusion on limitation of incidental or consequential damages, or on how long an implied warranty lasts, so the above limitations may not apply to you. This warranty gives you specific legal rights, and you may also have other rights, which may vary from state to state.

Manufactured by
VALOR HEATING
BIRMINGHAM, ENGLAND



Distributed in the USA by
GASM
Portland, TN 37148

Because our policy is one of constant development and improvement, details may vary slightly from those in this publication.