

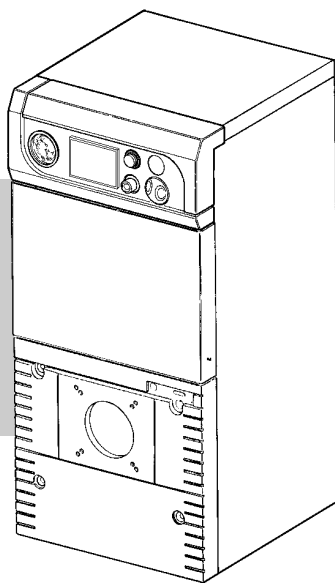

# GN1



**CAST IRON HIGH EFFICIENCY SECTIONAL BOILER,  
FOR GAS/OIL FUELS**





## **Index**

- 1.** Technical informations
- 2.** Dimensions and technical data
- 3.** Packing and shipping details
- 4.** Installation
- 5.** Testing
- 6.** Service
- 7.** Boiler components
- 8.** Option

## 1. Technical informations

### 1.01 Introduction

**GN1** boiler is a new heating generator with high efficiency, for central heating system as well sanitary hot water production suitable for burners using oil or gas.

The boiler body is built by cast iron sections joined together by mean of biconical nipples and tie rods. Sections fins are especially developed to achieve the best efficiency of the boiler in order to save on fuel consumption. The boiler body insulation is provided by mineral high density fibers that minimizes the body heat lost.

#### Key

- 1 Timer sochet
- 2 Thermomanometer
- 3 Security thermostat manual resetting
- 4 Main switch
- 5 Control thermostat

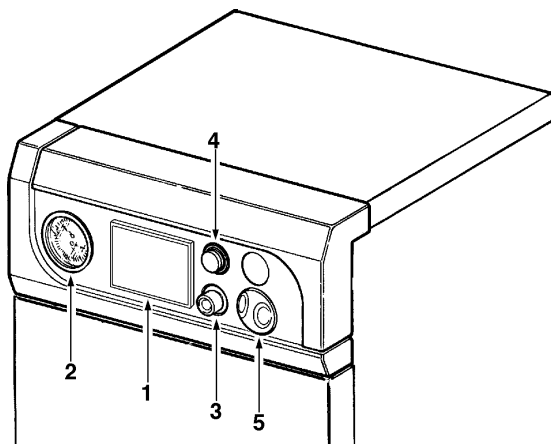

Fig. 1

### 1.02 Control and securities devices operation

#### Regulating thermostat, manual resetting 3 (fig. 1)

It operates when the boiler temperature, during the heating mode reach such a level that can use a danger situation. Before resetting this thermostat ask for Qualified Serviceman to inspect the appliance.

#### Central thermostat 5 (fig. 1)

It allows to control the boiler temperature by mean of its knobs.  
This thermostat controls the burner.

#### Room thermostat (not supplied)

This device is not supplied, but can be fitted by installer, it is connected in series to the control thermostat and it manages both the burner and the circulating pump during the heating mode. The use of such appliance is advised to get a better comfort as well on energy saving.

## 2. Dimensions and technical data

### 2.01 Dimensions and technical data (fig. 2 - tab. 1)

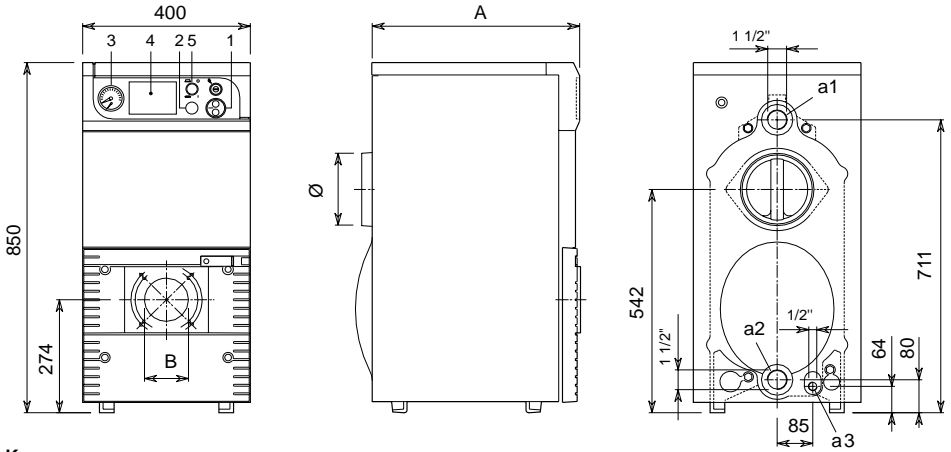

#### Key

- a1 Flow 1 1/2"
- a2 Return 1 1/2"
- a3 Boiler drain 1 1/2"

Fig. 2

Model	Heat and D.H.W. (gross) gas Max.	Heat and D.H.W. (net) gas+oil Max.	Heat and D.H.W. output Max.	Heat and D.H.W. (gross) gas Min.	Heat and D.H.W. (net) gas+oil Min.	Heat and D.H.W. output Min.	N° element	Water capacity dm <sup>3</sup>	Combustion chamber lenght mm	Combustion chamber dimension Ømm
GN1 02	28,6	25,8	23,3	18,2	16,4	15,0	2	11	286	260x310
GN1 03	43	38,7	34,9	18,2	16,4	15,0	3	14	386	260x310
GN1 04	57,3	51,6	46,5	39,3	35,4	32,5	4	17	486	260x310
GN1 05	71,6	64,5	58,1	49,1	44,2	40,5	5	20	586	260x310
GN1 06	86,1	77,5	69,8	59,1	53,2	48,8	6	23	686	260x310
GN1 07	100,4	90,4	81,4	68,8	62,0	57,0	7	26	786	260x310
GN1 08	114,7	103,3	93,0	78,6	70,8	65,0	8	29	886	260x310

Model	Working pressure bar	A	B	Ø	Combustion chamber load loss Δp mbar	Combustion chamber volume dm <sup>3</sup>	Water load losses		Weight of unit kg.
							Δt 10	Δt20	
GN1 02	4	300	105	130	0,2	12,09	1	-	75
GN1 03	4	400	105	130	0,2	20,15	1,8	-	100
GN1 04	4	500	105	130	0,2	28,21	4,2	1	125
GN1 05	4	600	105	180	0,2	36,27	7,2	1,6	150
GN1 06	4	700	125	180	0,2	52,39	11	2,3	175
GN1 07	4	800	125	180	0,2	60,45	15	3,3	200
GN1 08	4	900	125	180	0,2	68,51	20	4,5	225

**N.B.:** - Max. water temperature for the heating system is 90° C. - Min. water temperature for the heating system is 45° C.

**2.02 Pressure drop (fig. 3)**

Pressure drops according to the boiler size are specified on the following diagram and refer to temperature difference between flow and return comprises between 10 and 20°C.

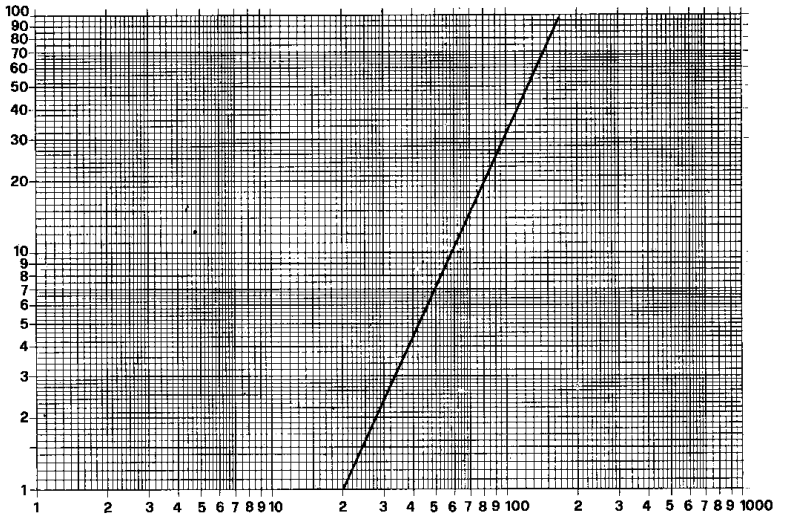

Fig. 3

**3. Packing and shipment**

Boiler is delivered complete assembled in a wood crate.

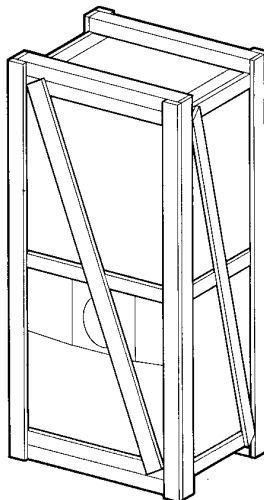
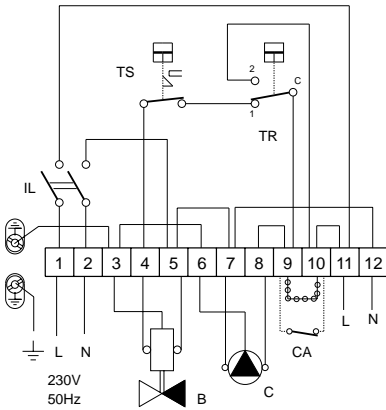

Fig. 4

## Electrical diagram



- IL = MAIN SWITCH
- CA = CONNECTION AUXILIARY
- TR = BOILER THERMOSTAT
- TS = SAFETY THERMOSTAT
- B = BURNER
- C = CIRCULATING PUMP
- 11-12 = AVAILABLE CLAMPS
- REMOVE THE LINE IF ROOM THERMOSTAT IS FITTED

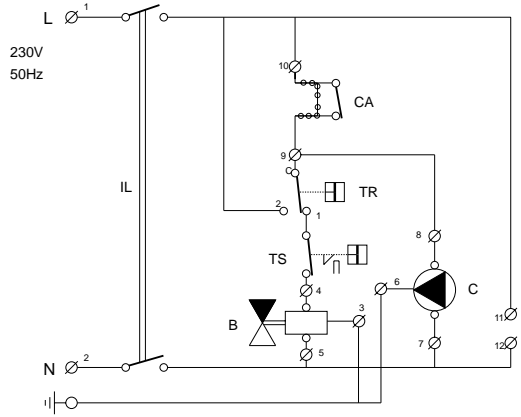

Fig. 5

## 4. Installation

It is law that all gas appliances are installed by Competent Persons, in accordance with the regulations. Failure to install appliances correctly lead to prosecution, it is your own interest, and that of safety, to ensure that the law is copied with. Manufacturers instructions must NOT be taken in any way as over-riding statutory obligations, special care must be paid to conform with law and regulation concerning building and location of the chimney.

### 4.01 Electrical connection

Proceed to wire pump, burner and optional room thermostat. According to the wiring diagrams (fig.5) and to the directions attached to the cables. It is recommended to install a two-pole switch between the power supply and the boiler. The switch contacts must have a clearance of at least 3 mm and fuses of 5 A max must be provided.

**N.B. - Appliance must be earthed.**

**It is recommended to connect the boiler to a good electric earth system.**

**FERROLI could not be considered responsible for any kind of damage to Persons or things caused by failure of earthing the system.**

## **4.02 Hydraulic connections**

Boiler must be connected to the system according to boiler back part indications and those provided at fig. 2. Pipe must be free of any kind of strain and security valves must be provided in both central heating system and domestic hot water system location of such security valves be as close as possible to the boiler and between the boiler and valve no obstructions or gate valves must be placed.

The boiler is not supplied with expansion tank it has to be provided during the boiler installation. It is advised that the pressure in the hydraulic system has to be between 0,5 and 1 bar measured in cold water condition.

## **4.03 Connection to the chimney**

It is recommended to connect the boiler to a good working chimney built according to the regulations. The connection between boiler and chimney must be done by using suitable material proof against high temperature and corrosion. Where flue sections have to be connected it is advised pay attention to avoid leaking and provided good insulation through all the flue length to avoid condensing problem.

## **5. Testing**

### **5.01 Before the first light of the boiler**

Before the first light of the boiler follow these check list:

- a) check the system is filled with water at the right pressure;
- b) check against any leakage of water fuel;
- c) check that the correct electric power is supplied to the unit;
- d) check size and perfect flue installation;
- e) check against any type of flammable materials where the boiler is installed;
- f) check the burner has the right heat input according to the boiler size;
- g) control that the water valves are open.

### **5.02 First lighting**

After the boiler preliminaries checking , the appliance can be lights in the following way;

- 1) Open the fuel gate valve.
- 2) Set the regulating thermostat at the required temperature level.
- 3) Give electric power to the boiler and switch on the main switch 4 (fig. 1) on the boiler control panel.

After above operations the burner will start to run and the boiler will begin to work.

### **5.03 After the first lighting**

After the first lighting it is advisable check:

burner works properly, this checking must be done by appropriate instruments.

Thermostats operate correctly.

Water flows through the system.

Smoke gases evacuate through the flue duct.



### 5.04 Switch off

To turn off the unit for a short period it is enough to switch off the switch 4 (fig. 1) on the control panel.  
If the boiler has to be stopped for long period beside to act by the switch 4, it is necessary to cut the supply of fuel by mean of the gate valve, in winter season, to avoid damages due to the frost it is necessary to add the antifrost liquid in the system or to drain it completely.

## 6. Service

The after sale service must be carried out only Qualified Plumbers. It is advise to service the boiler at least once a year, before the winter season. Check must include the boiler cleaning, the perfect operation of the controls and the burner.

Furthermore the flue duct conditions have to be inspected.

### 6.01 Boiler cleaning

Cut out electric power.

The front panels 1, 2, 3 (fig. 6).

Clean the boiler internal parts.

Check the flue duct and if necessary clean it.

The burner service must be done according the Manufacture Instructions.

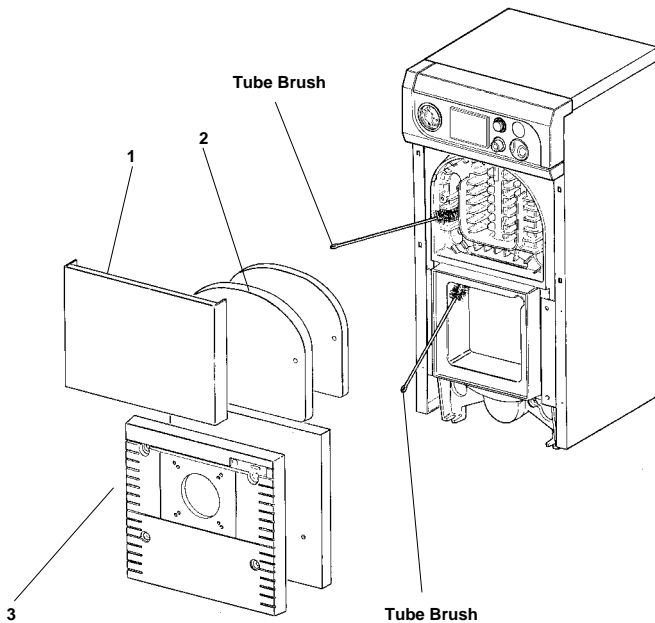
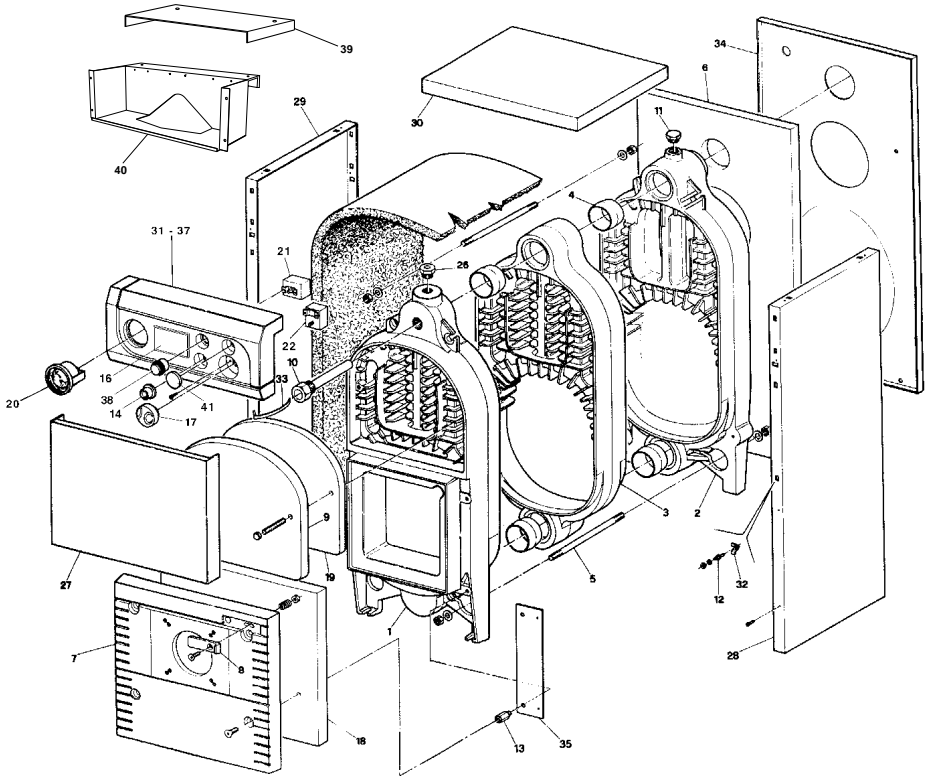

Fig. 6

## 7. Boiler parts



POS. CODE	DESCRIPTION	POS. CODE	DESCRIPTION	POS. CODE	DESCRIPTION			
1	33004920	FRONT SECTION	15	35000390	TUBE BRUSH	29	37025720	LEFT PANEL FOR GN1 06
2	33004710	REAR SECTION	16	35003370	MULTIFUNCTIONAL CONTROL SYSTEM (not supplied)	29	37025730	LEFT PANEL FOR GN1 07
3	33004720	MIDDLE SECTION	17	35002420	KNOB	29	37025740	LEFT PANEL FOR GN1 08
4	34204000	BICONICAL NIPPLE	18	35316550	ISOLATION PANEL	30	37025750	COVER FOR GN1 02
5	34400010	THE ROD M10x140	19	35316340	ISOLATION PANEL	30	37025760	COVER FOR GN1 03
5	34403010	THE ROD M10x245	20	36400790	THERMOHYDROMETER	30	37025770	COVER FOR GN1 04
5	34400910	THE ROD M10x340	21	36401450	SECURITY THERMOSTAT	30	37025780	COVER FOR GN1 05
5	34400920	THE ROD M10x440	22	36401210	BOILER THERMOSTAT	30	37025790	COVER FOR GN1 06
5	34400930	THE ROD M10x540	26	36901140	NO RETURN VALVE	30	37025800	COVER FOR GN1 07
5	34403170	THE ROD M10x630	27	37025600	FRONT PANEL	30	37025810	COVER FOR GN1 08
5	34403180	THE ROD M10x740	28	37025610	RIGHT PANEL FOR GN1 02	31	38508420	COMPLETE CONTROL PANEL
6	33100600	REAR INSULATION D140	28	37025620	RIGHT PANEL FOR GN1 03	32	31000210	SPRING
6	33100610	REAR INSULATION D180	28	37025630	RIGHT PANEL FOR GN1 04	33	31000260	PLATE SPRING
7	33202060	BURNER DOOR	28	37025640	RIGHT PANEL FOR GN1 05	34	31132520	REAR PANEL FOR GN1 02-03
7	33202080	BURNER DOOR	28	37025650	RIGHT PANEL FOR GN1 06	34	31132540	REAR PANEL FOR GN1 04-08
8	33202100	SPY HOLE COVER	28	37025660	RIGHT PANEL FOR GN1 07	35	31205870	CLAMP
9	33202120	UPPER DOOR	28	37025670	RIGHT PANEL FOR GN1 08	37	35005150	BARE CONTROL PANEL
10	33400720	PROBES POCKET	29	37025680	LEFT PANEL FOR GN1 02	38	36100290	SWITCH
11	34000610	PLUG	29	37025690	LEFT PANEL FOR GN1 03	39	32910840	WIRING BOX
12	34000640	FASTENING PIN	29	37025700	LEFT PANEL FOR GN1 04	40	32910760	WIRING BOX COVER
13	34010220	STUD	29	37025710	LEFT PANEL FOR GN1 05	41	35002880	PLASTIC PLUG





**ALL SPECIFICATIONS SUBJECT TO CHANGE**

**Stockton Close, Minworth Industrial Park, Minworth, Sutton Coldfield, West Midlands B76 8DH**  
**Tel.: 0121/3523500 - Fax 0121/3523510**

---