

Baxi Belmont 2 & Baxi Wentworth Classic Fan Flue

Live Fuel Effect Inset Gas Fires

Comp No 244628 - Iss 5 - 2/00

Installation and Servicing Instructions

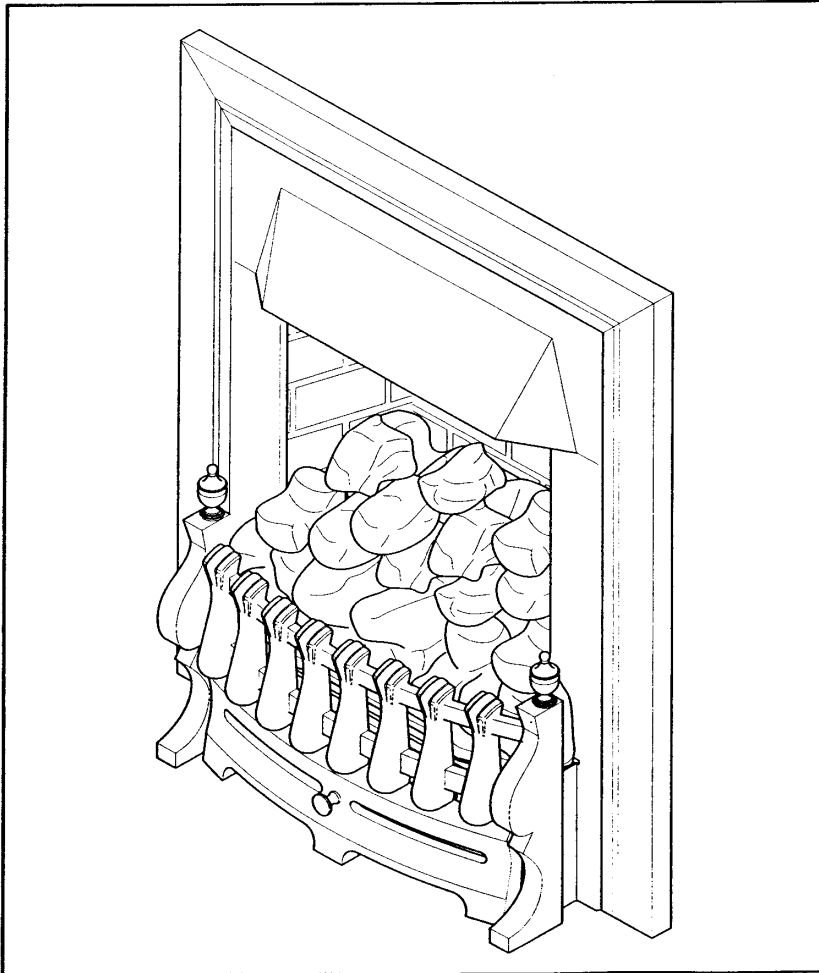

BAXI

Natural Gas

Baxi Belmont 2 Fan Flue

G.C. N° 32 075 23

Baxi Wentworth Classic Fan Flue

G.C. N° 32075 14A

Baxi Limited is one of the leading manufacturers of domestic heating products in the UK.

Our first priority is to give a high quality service to our customers. Quality is built into every Baxi product - products which fulfil the demands and needs of customers, offering choice, efficiency and reliability.

To keep ahead of changing trends, we have made a commitment to develop new ideas using the latest technology - with the aim of continuing to make the products that customers want to buy.

Baxi is also the largest manufacturing partnership in the country. Everyone who works at the company has a commitment to quality because, as shareholders, we know that satisfied customers mean continued success.

We hope you get a satisfactory service from Baxi. If not, please let us know.

For use in GB / IE only.



Baxi is a BS-EN ISO 9001
Accredited Company

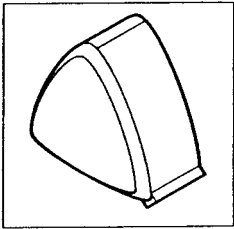
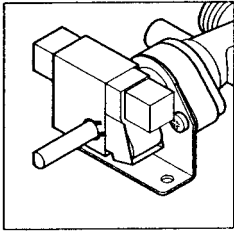
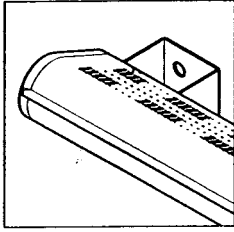

Section		Page
1.0	Introduction	4
2.0	Technical Data	6
3.0	Site Requirements	7
4.0	Electrical	9
5.0	Installation	11
6.0	Commissioning the Fire	21
7.0	Arranging the Coils	22
8.0	Checking for Spillage	25
9.0	Fitting the Trim & Fender	26
10.0	Annual Servicing	27
11.0	Changing Components	31
12.0	Short Parts List	37

1.1 Description

1. The Baxi Belmont 2 and Wentworth Classic Fan Flue are live fuel effect inset gas fires designed to be used on Natural Gas only at a setting pressure of 20 mbar.

2. The appliance is designed to give a maximum heat output of 3.0 kW (10,236 Btu/h).

3. The fire is controlled by a knob which is positioned behind the controls access door on the fender assembly (Fig. 1). The knob has four positions:

- Position ● Off
- Position ★ Ignition
- Position 🔥 Minimum Output
- Position 🔥 Maximum Output

4. The fan is controlled by the two rocker switches adjacent to the control knob (Fig. 1).

5. A special feature of the Baxi Belmont 2 and Wentworth Classic is the direct acting oxygen depletion system. This system will shut down the appliance if there is inadequate ventilation and the flue is not clearing the products of combustion. **Under no circumstances shall this device be adjusted, bypassed or put out of action.** The device must be regularly serviced and strictly in accordance with these instructions.

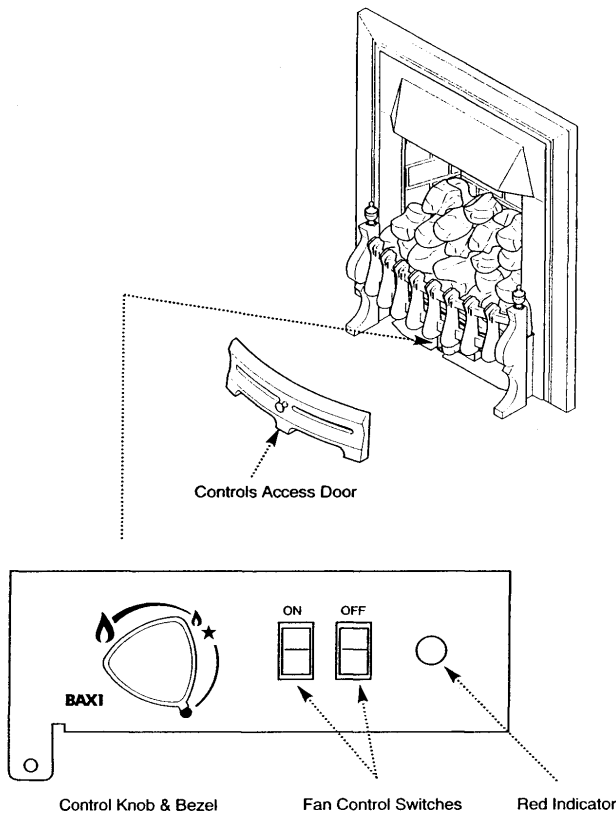

Fig. 1

NOTE: A red indicator (Fig. 1) shows when the electric power is ON but the fan is not running.

The fire incorporates a fan so that it can be installed in a room without a flue. The fan removes the products of combustion horizontally through a flue duct which exits at the rear of the appliance.

1.2 Important Information

This product contains Refractory Ceramic Fibres (R.C.F.) which are man-made vitreous silicate fibres. Excessive exposure to these materials may cause temporary irritation to eyes, skin and respiratory tract. Care must be taken when handling these articles to ensure the release of dust or fibres is kept to a minimum. To ensure that the release of fibres from these articles is kept to a minimum, during installation and servicing it is recommended that a H.E.P.A. filtered vacuum is used to remove any dust, soot or other debris accumulated in and around the appliance. This should be performed before and after working on the installation, It is recommended that any replaced item(s) are not broken up but sealed within heavy duty polythene bags and clearly labelled R.C.F. waste". This is not classified as "hazardous waste" and may be disposed of a tipping site licensed for the disposal of industrial waste. Protective clothing is not required when handling these articles but it is recommended that gloves are worn and the normal hygiene rules of not smoking, eating or drinking in the work area are followed and always wash hands before eating or drinking.

1.3 Installation

1. The appliance is suitable for installation only in G.B. and I.E. and should be installed in accordance with the rules in force. For Ireland install in accordance with I.S.813 "installation of Gas Appliances". The installation must be carried out by a Corgi Registered Installer or other competent person and be in accordance with the relevant requirements of Gas Safety (Installation and Use) Regulations 1998 (as amended), the Building Regulations issued by the Department of the Environment, Building Standards (Scotland) (Consolidation) Regulations issued by the Scottish Development Department and the Local Building Regulations. Where no specific instructions are given, reference should be made to the relevant BRITISH STANDARD CODES OF PRACTICE and Installation Specifications.

2. This appliance must be installed in accordance with the manufacturers instructions and the rules in force and only used in a suitably ventilated location.

3. Read the instructions before installing or using this appliance.

4. Ensure that all protective plastic coating is removed from trim and fender parts.

IMPORTANT: Do not push excess electrical cable into void behind the fender.

1.4 B.S. Codes of Practice

<u>STANDARD</u>	<u>SCOPE</u>
B.S. 6891	Gas Installation.
B.S. 5440: Pt 1	Flues.
B.S. 5440: Pt 2	Air Supply
B.S. 5871: Pt 2	Installation of inset live fuel effect fires.

Notice

Discolouration of wall surfaces

Most heating appliances generate warm air convection currents and transfer heat to any wall surface against which they are situated.

Some soft furnishings (such as blown vinyl wallpapers) may not be suitable for use where they are subject to temperatures above normal room levels and the manufacturer's advice should be sought before using this type of wall covering adjacent to any heating appliance.

The likelihood of wall staining from convected air currents will be increased in environments where high levels of tobacco smoke or other contaminants exist.

**Belmont 2 Fan Flue
Wentworth Classic Fan Flue**

Category of Appliance I_{2H}
The fire is set for Gas Type G20 at 20mbar.

Heat Input (net)	High	Min	
	kW	6.16	2.4
	Btu/h	21,018	8,200

Heat Output	High	
	kW	3.0
	Btu/h	10,236

Inlet Setting Pressure	Cold	
	mbar	20 ± 1.0
	in wg	8 ± 0.4

Gas Connection 8mm OD tube, rigid or semi rigid and 8mm compression fitting at appliance inlet

Terminal Position with Minimum Distance (Fig. 17)	(mm)	Controls & Safety system	Rotary gas tap with direct burner ignition, flame failure device, direct acting oxygen depletion system and a fan on/off switch with fan off indication	
A Directly below an openable window or other opening, e.g. an air brick.	300	Gas Rate 0.65 m ³ /h (after 10 mins) (23.0 ft ³ /h)	Lifting Weight 18.3 kg (40 lbs)	
B Below gutters, soil pipes or drain pipes.	75			
C Below eaves.	200			
D Below balconies or car port roof.	200			
E From vertical drain pipes and soil pipes.	75			
F From internal or external corners.	300			
G Above ground, roof or balcony level.	300			
H From a surface facing a terminal.	600			
I From a terminal facing a terminal.	1200			
J Vertically from a terminal on the same wall.	1500			
K Horizontally from a terminal on the same wall.	300			
L For an opening in a car port (e.g. door, window) into a dwelling.	1200			
				Injector Cat 127/440
				Trim Dimensions Height 601 mm Width 512 mm Depth 125 mm (from the wall)
		Electricity Supply 230 Volts Fan supply		

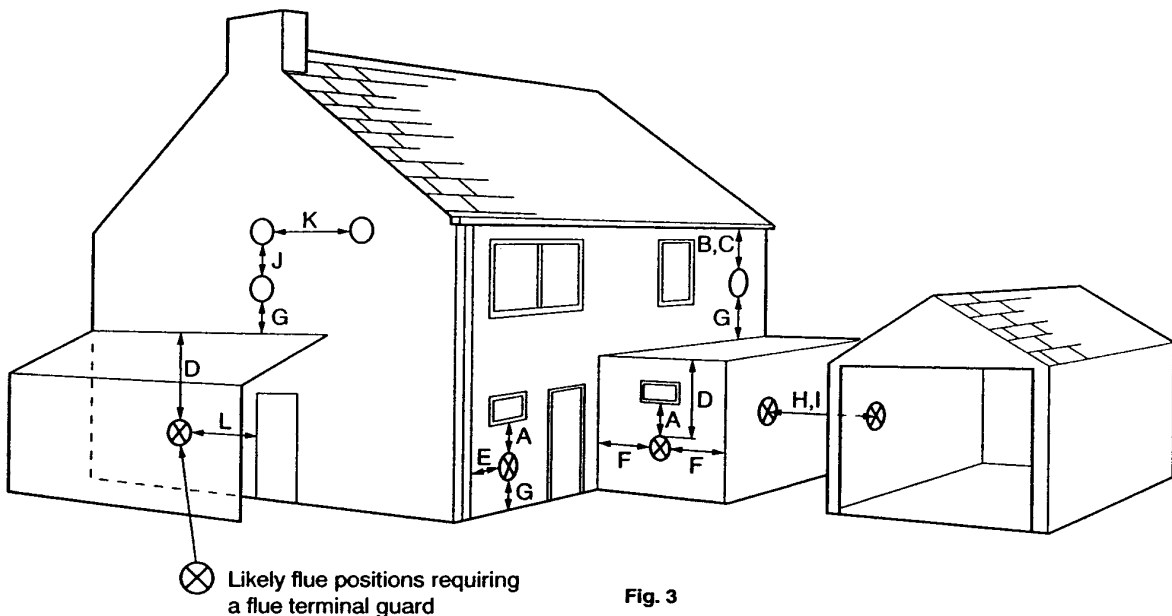
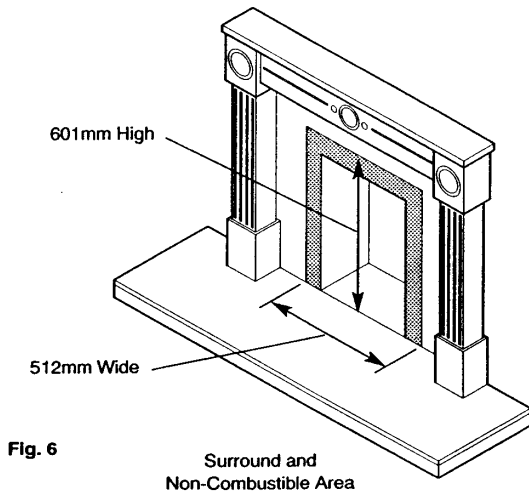
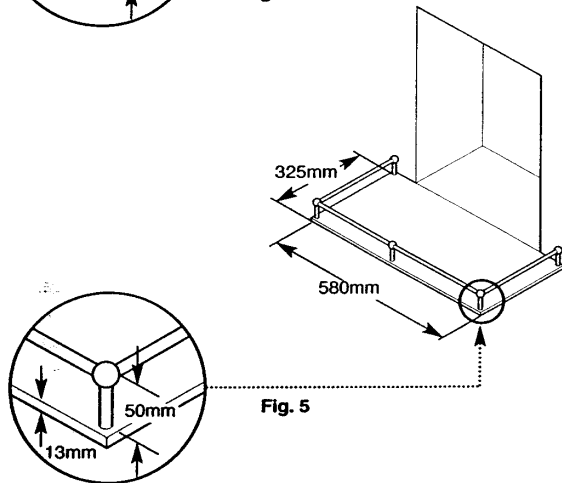
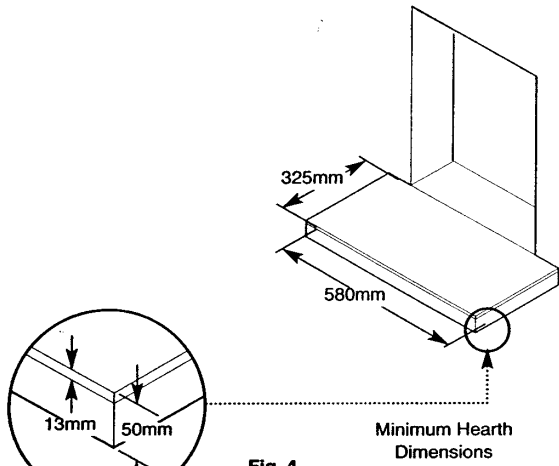

Fig. 3



3.1 Location

1. The Baxi Belmont 2 and Wentworth Classic Fan Flue gas fires must be installed on an outside wall. The maximum distance from the rear face of the fire mounting frame to the outside face of the wall is 600mm. The minimum is 300mm. The effective wall thickness can be increased by the addition of an internal fire surround.

2. The flue terminal must be located in a suitable position on an outside wall taking into consideration the dimensions shown in Fig. 3.

3.2 Ventilation

1. No purpose provided ventilation is normally required for the appliance, normal adventitious room ventilation being sufficient. Reference should be made to BS 5871 Part 2. For Ireland refer to IS 813 Section 10 of the Irish Ventilation Requirements.

3.3 Hearth Mounting

1. The fire is intended to be hearth mounted only. The hearth must be of a non-combustible material at least 13mm ($\frac{1}{2}$ in) thick and measuring at least 325mm ($12\frac{7}{8}$ in) deep, measured from the mounting wall face, by 580mm ($22\frac{27}{32}$ in) wide. It must be fitted central to the fireplace opening. The top surface of the hearth should be a minimum of 50mm (2 in) above floor level (Fig. 4).

2. The fire must also stand on a non-combustible base inside the fireplace opening, the same height as the hearth.

3. On no account should the fire unit be fitted directly onto a combustible floor or carpet.

4. Alternatively, a fender rail or upstanding edge of 50mm (2in) height can be fitted to the periphery of the 13mm ($\frac{1}{2}$ in) non-combustible hearth (Fig. 5).

3.4 Purpose Built Hearths & Surrounds

1. Purpose built fire resistant hearths and back panels specified as suitable by the manufacturer, or a suitable propriety fire surround with 150° C rating may be used.

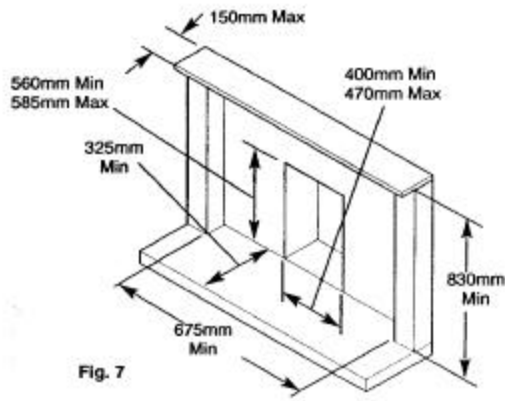

Fig. 7

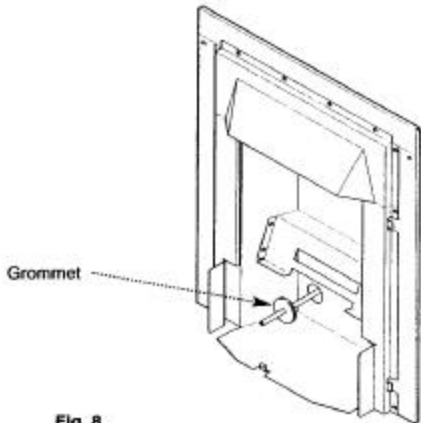

Fig. 8

Fit grommet over gas pipe and fit in hole in box once box is fitted back.

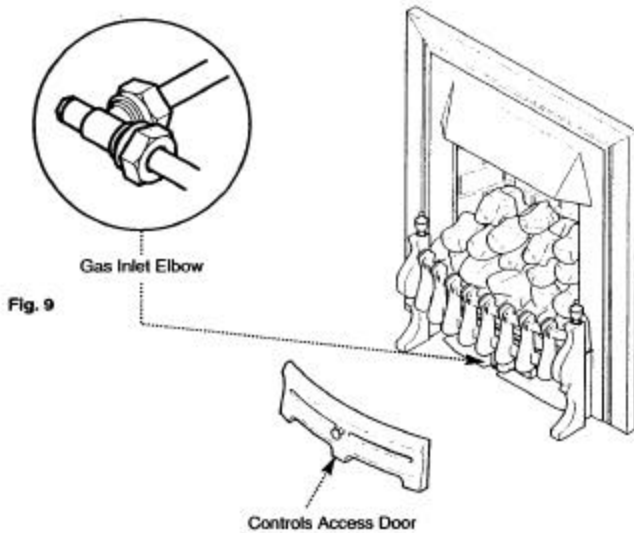

Fig. 9

3.5 Clearances (Fig. 7)

1. **Shelf Clearance** - minimum clearance from the hearth to the underside of a combustible shelf should be 830mm ($32\frac{21}{32}$ in) provided the shelf depth is 150mm ($5\frac{29}{32}$ in) or less. When the shelf depth is increased by increments of 12.5mm ($\frac{15}{32}$ in) greater than 150mm ($5\frac{29}{32}$ in), add 25mm (1in) to the 830mm ($32\frac{21}{32}$ in).

2. **Side of Fire** - minimum width between vertical sides of a combustible surround should not be less than 675mm ($26\frac{5}{16}$ in) provided the fire is central to the surround and the sides do not project forwards more than 150mm ($5\frac{29}{32}$ in). For every 12.5mm ($\frac{1}{2}$ in) that the projection of the sides is increased by, add a further 50mm (2 in) to the inside width of the surround. **NOTE:** When the fire is fitted, this gives a minimum side clearance of 150mm ($5\frac{29}{32}$ in).

3.6 Gas Supply & Connection

1. The gas supply is to be connected to the appliance as a concealed fix from the rear.

Turn off any appliances that are fed by the meter and isolate the gas supply by turning off at the meter.

2. It is advisable to route the supply to the left side of the unit taking into account the requirements of BS 6891:1988 dealing with enclosed pipes.

3. It is necessary to remove the grommet from the left hand hole in the fire back panel. The grommet must be cut in order to accommodate the gas pipe and replaced as in Fig. 8. The pipe can then be routed to the inlet elbow. (Fig. 9)

4. A suitable isolating cock should always be fitted in the supply feed to the fire to facilitate servicing.

4.1 Electrical Supply & Connection

1. All external wiring to the appliance must be in accordance with the latest I.E.E. Wiring Regulations and any local regulations that apply.
 2. Ensure that any cables are not pulled tight and that it is possible to isolate the electrical supply to the fire for servicing.
 3. In the event of an electrical fault after installation of the appliance, preliminary electrical system checks must be carried out i.e. earth continuity, short circuit, polarity and resistance to earth.
 4. Fuses used in this installation must be ASTA approved to BS 1362.
 5. **The appliance must be earthed.**
 6. Any additional cable used should be 0.75 mm² (24 x 0.2mm) PVC heat resistant as specified in table 16 of BS 6500.
 7. Where the cable passes through brickwork or similar it should be suitably protected and sealed.
 8. This appliance requires a suitable 230 ~ 50Hz supply to the fan box. The supply lead should be routed to a suitable socket inside the house. If this lead is not long enough it may be removed from the plug and a new cable fitted and wired to a 3 A double pole isolating switch with a contact separation of at least 3mm in both poles or to a 3 pin plug which should also be fused at 3 A. This plug or isolating switch should be readily accessible to the user to enable the electrical supply to be switched off as required.
-

4.2 Schematic Wiring Diagram

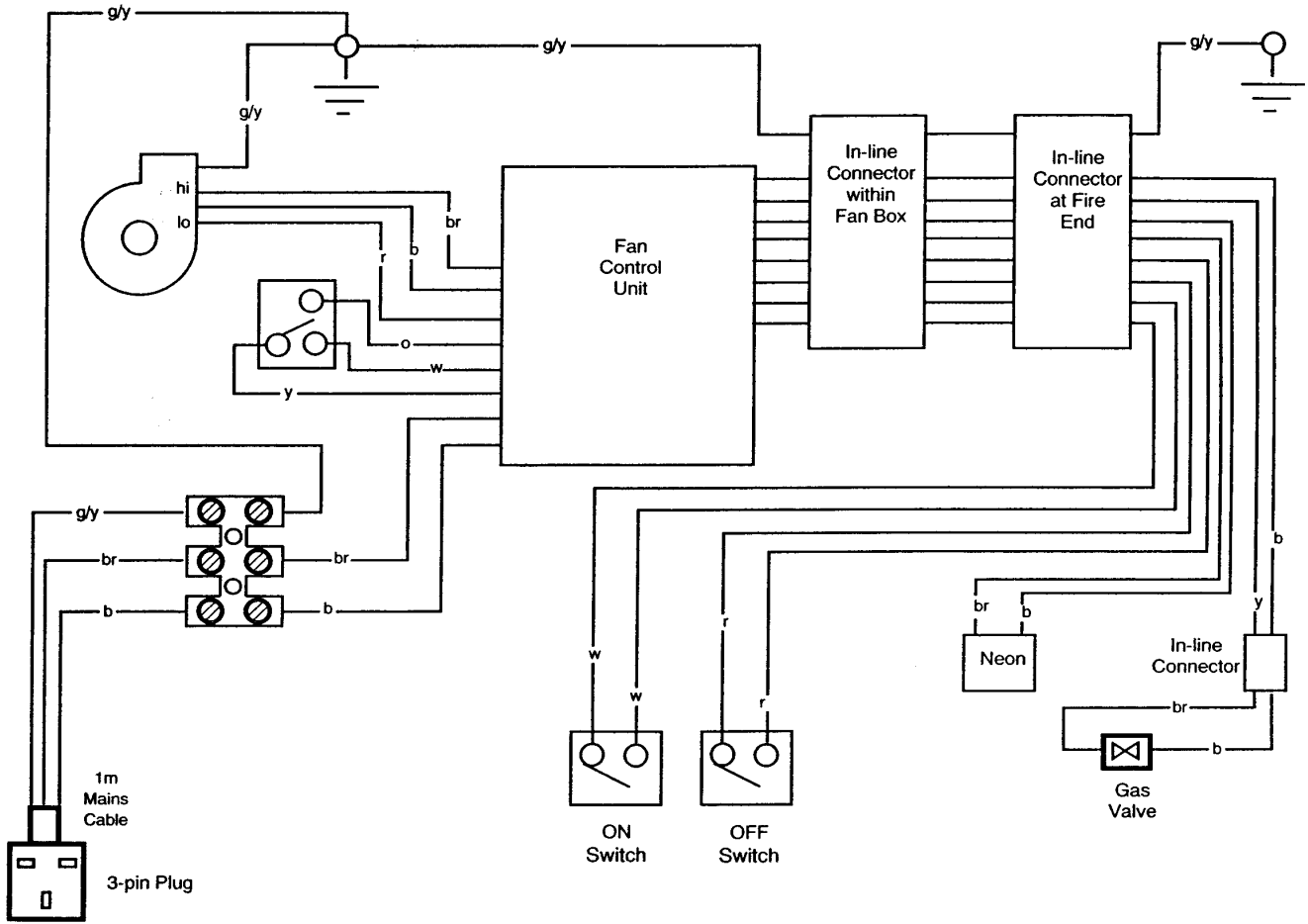

Fig. 10

- Key
- g = green
 - b = blue
 - br = brown
 - bl = black
 - w = white
 - r = red
 - y = yellow
 - v = violet
 - o = orange
 - g/y = green/yellow

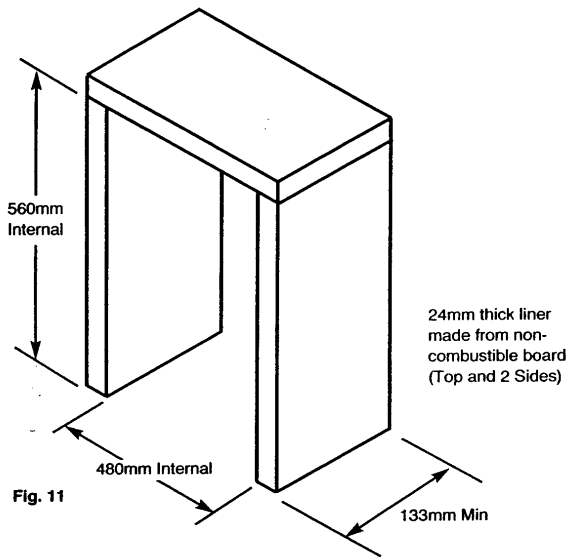

Fig. 11

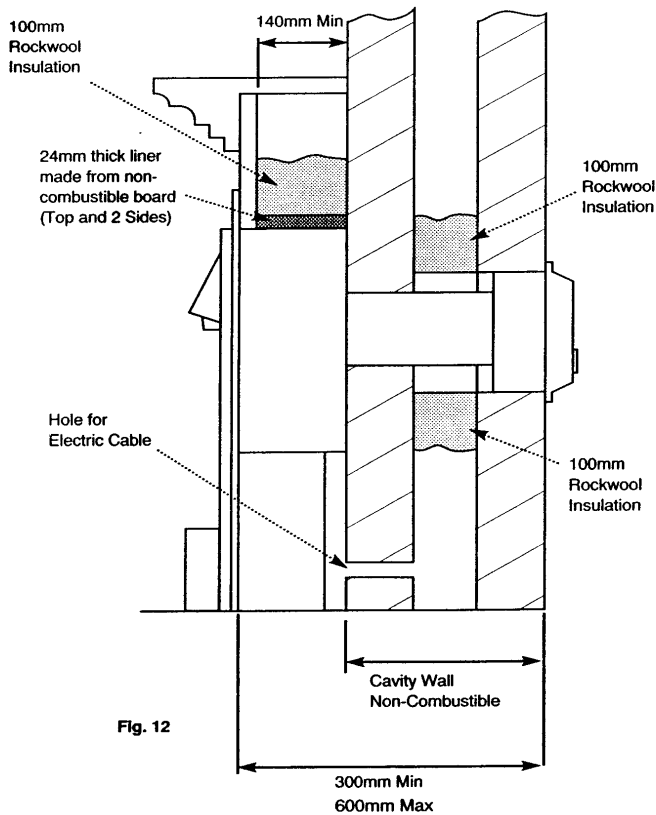

Fig. 12

5.1 Initial Preparation

1. Unpack the appliance from the carton and check all items are present. The ceramic coal bed items should be left in their box until required.
2. Some sheet metal parts may be fitted with protective plastic coating which must be removed prior to installation.

5.2 General Preparation

1. Make sure the chosen position will comply with the installation requirements detailed in section 3.0 Site Requirements.
2. Make sure the damp course and any electrical wiring or piping in the wall is not affected by the installation.
3. Any gas supply pipe concealed in a wall, floor or cavity must be continuous and enclosed in a gas tight sleeve. (Gas Safety (Installation and Use) Regulations 1994 as amended).
4. The fire can be fitted into a surround or false chimney breast in front of a non-combustible wall, into a recess within a brick, block or stone cavity wall, or into a timber framed dwelling.

5.3 Preparation of the Site - Fire In front of the wall

1. This installation details the use of a fire surround or false chimney breast having a minimum depth of 140mm. This will allow the fire to be positioned in front of the wall with a hole in the inner wall for the flue only. The maximum surround depth will depend upon the wall thickness. The maximum total depth is 600mm from the outer wall face to the rear face of the outer fire frame. The minimum total depth is 300mm.
2. Any combustible material within the installation must be at least 75mm away from the appliance, the flue box and the circular horizontal flue.
3. A suitable liner should be made to enclose the fire (Fig. 11). This should be fitted within the false fire surround. It should be 24mm thick and be of Supalux or similar non-combustible board. If 24mm material is not available two or more smaller boards may be used. It should extend from the outer fire frame to the inside face of the wall. When fitted, this box should be insulated to the top and sides with 100mm of Rockwool (Fig. 12).

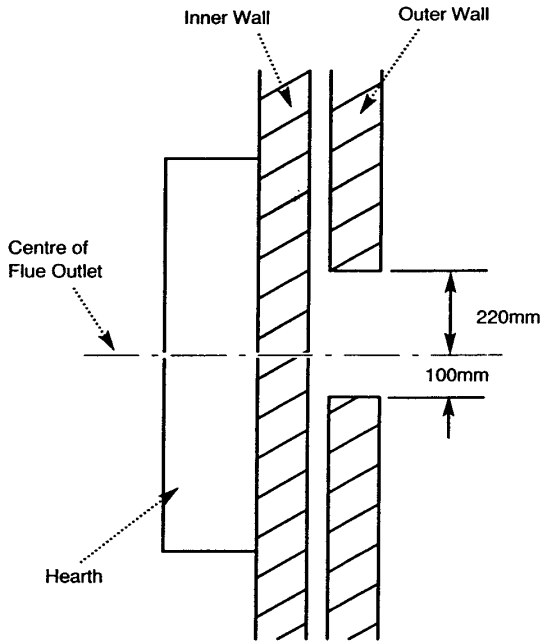

Fig. 13 Plan View

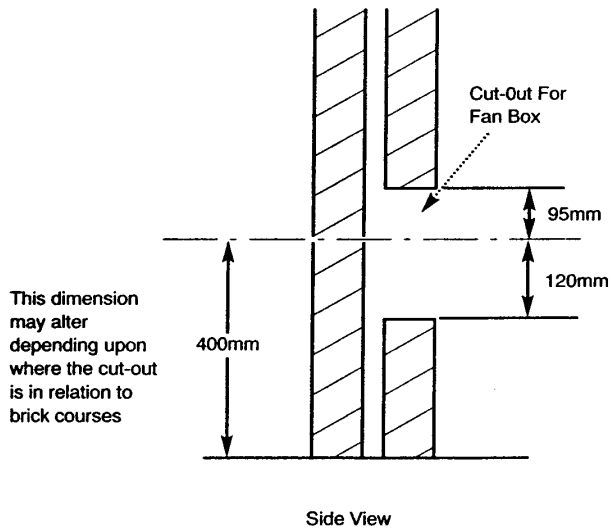

Fig. 14

5.3 Preparation of the Site (cont)

4. Measure 400mm up from hearth level and mark this dimension on the wall. Drill through the inner and outer walls at the mark using a suitable pilot drill at a point corresponding to the centre line of the fire flue outlet (Fig. 14).

5. From outside consider the position of the pilot hole in relation to the brickwork. The fan box is 3 bricks high and requires a cut-out in the wall 95mm above and 120mm below the pilot hole. This cut-out must extend 100mm to the left and 220mm to the right of the pilot hole (Fig. 13).

6. If the position of the fan box cut-out would be such that it does not coincide with the brick courses the pilot hole position can be re-marked 40mm up or down. The fan box cut-out can then be marked relative to this new position.

7. If this is necessary the flue outlet on the rear of the fire can be adjusted accordingly by undoing the six securing screws. It may be necessary to remove the flue outlet plate and fit it the other way up to achieve the desired amount of adjustment. Precise adjustment of the flue height can be carried out when the flue duct is fitted.

8. Cut a hole 100mm diameter in the inner wall at the required height for the flue duct.

9. A separate hole approximately 35mm diameter should be made through the inner wall towards the bottom right hand corner of the fire location to enable the electrical cables to pass through the wall and connect the fire to the fan box and allow for the 230V supply cable to the fan box.

10. From outside cut a neat rectangular hole for the fan box assembly. The cavity should be sealed where the flue duct will pass through. Use Rockwool or similar to each side of the opening to a thickness of at least 100mm.

Proceed to section 5.5 Fitting the Fan Box

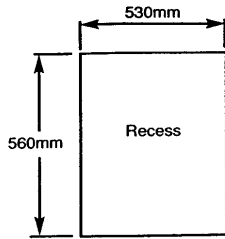

Fig. 15

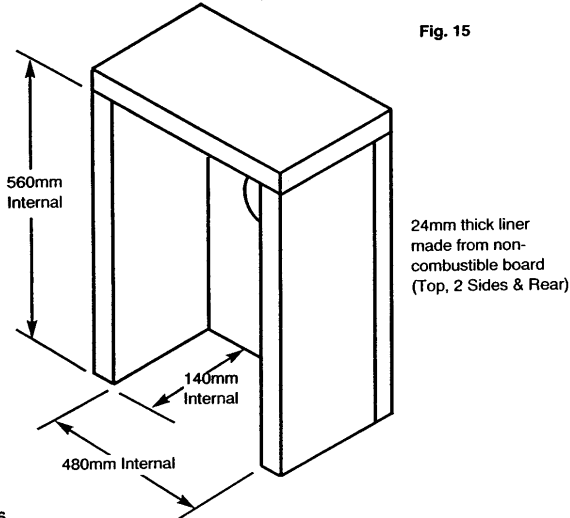

Fig. 16

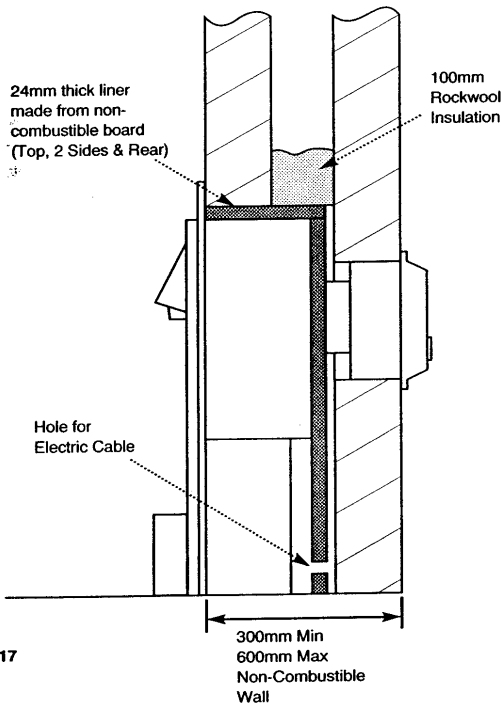

Fig. 17

5.4 Preparation of the Site - Fire fitted Into a recess

1. A suitable liner should be made to enclose the fire (Fig. 16). This should be fitted within the false fire surround. It should be 24mm thick and be of Supalux or similar non-combustible board.
If 24mm material is not available two or more smaller boards may be used. It should extend from the front of the fire mounting face to the inside face of the outside wall. The outside of this box should be insulated to the top and sides with 100mm of Rockwool when the box passes through the cavity between the inner and outer walls.
2. A hole 100mm diameter must be cut centrally in the rear panel of the liner for the flue duct. The height of the hole should be the height at which the pilot hole is to be drilled, or at its' adjusted position-see paragraph 4 to 7 below and Fig. 14. Also a hole approximately 35mm diameter should be cut in the lower right of the liner to accept the electrical cables.
3. Mark the position of the recess to be cut for the fire on the inside wall.
N.B. A lintel may be required above the cavity for the fire. If in doubt seek expert building advice.
4. Cut the cavity in the inner wall for the fire. Measure 400mm up from hearth level and mark this dimension centrally on the inner face of the outer wall. Drill through outer wall at the mark using a suitable pilot drill.
5. Consider the position of the pilot hole in relation to the brickwork. The fan box is 3 bricks high and requires a cut-out in the wall 95mm above and 120mm below the pilot hole. This cut-out must extend 100mm to the left and 220mm to the right of the pilot hole.
6. If the position of the fan box cut-out would be such that it does not coincide with the brick courses the pilot hole position can be re-marked 40mm up or down. The fan box cut-out can then be marked relative to this new position.
7. If this is necessary the flue outlet on the rear of the fire can be adjusted accordingly by undoing the six securing screws. it may be necessary to remove the flue outlet plate and fit it the other way up to achieve the desired amount of adjustment. Precise adjustment of the flue height can be carried out when the flue duct is fitted.
8. From outside cut a neat rectangular hole for the fan box assembly.

Proceed to section 5.5 Fitting the Fan Box

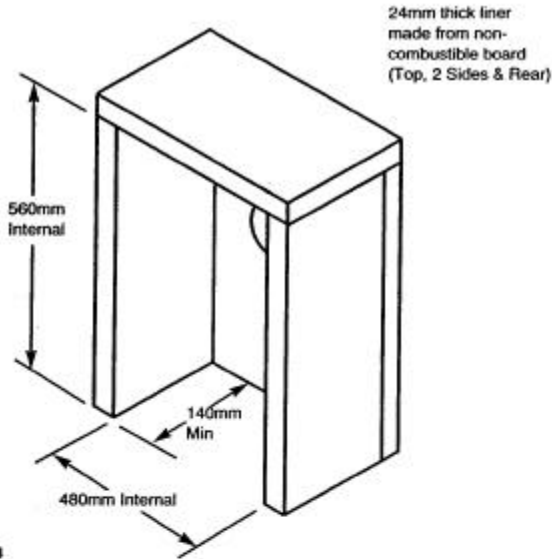

Fig. 18

5.4 Preparation of the Site - Timber Frame Dwelling

9. This installation requires a 150mm diameter piece of single wall flue pipe or similar for use as a metal sleeve (Fig. 19).

10. This installation details the use of a fire surround or false chimney breast, having a minimum depth of 140mm, which allows the fire to be positioned in front of the wall with a hole in the inner wall for the flue only. The maximum surround depth will depend upon the wall thickness. The maximum total depth is 600mm from the outer wall face to the rear face of the outer fire frame. The minimum total depth is 300mm.

11. Any combustible material within the installation must be at least 75mm away from the appliance, the flue box and the circular horizontal flue.

12. Installation must be in accordance with the current edition of Institute of Gas Engineers Publication IGE/UP/7 (Gas Installations in Timber Framed Housing).

13. A suitable liner should be made to enclose the fire. This should be fitted within the false fire surround. It should be 24mm thick and be of Supalux or similar non-combustible board. If 24mm material is not available two or more smaller boards may be used. It should extend from the outer fire frame to the inside face of the wall. When fitted, this box should be insulated to the top and sides with 100mm of Rockwool.

14. The back surface of the fire must be separated from the timber frame by 25mm of non-combustible material. This can consist of the usual 13mm plasterboard wall lining plus 12mm of Supalux or similar non-combustible board.

15. Measure 400mm up from hearth level and mark this dimension on the wall. Drill through the inner and outer walls at the mark using a suitable pilot drill, centrally in any surround.

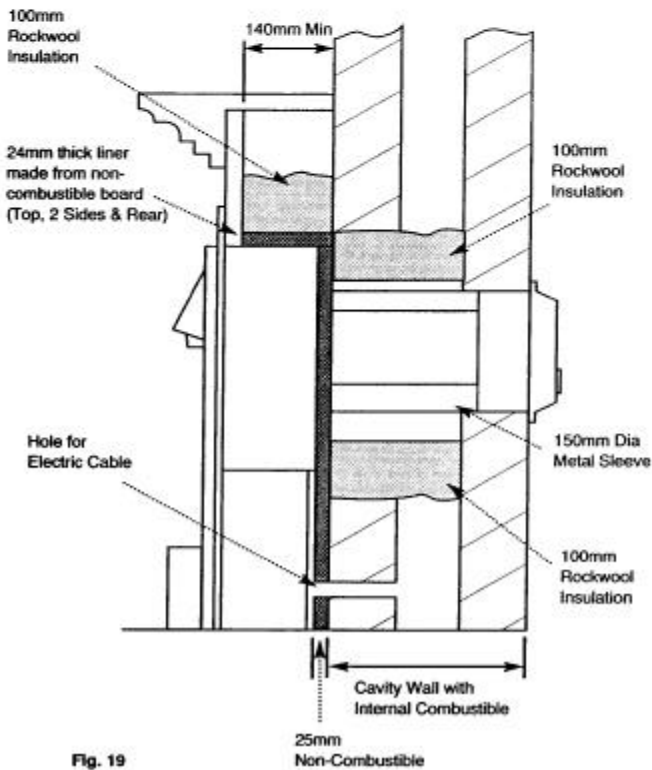

Fig. 19

5.4 Preparation of the Site (cont)

16. Taking into consideration the dimensions in fig.13 and 14 on page 12 and the position of the pilot hole, cut a suitable hole for the flue box assembly.

17. Once the height of the flue has been determined make a hole through the wall to accept a 150mm diameter sleeve. Ensure that when the 150mm diameter hole is cut through the wall and the rectangular recess is cut in the outer wall, no timbers are cut.

18. Make sure that the vapour barrier is cut carefully and made good to maintain its integrity.

19. A separate hole should be made towards the bottom Right Hand corner of the fire location to enable the electric cables to pass through the wall and connect the fire to the flue box and allow for the 230V supply cable to the fan box.

20. The cavity should be sealed where the flue box hole has been cut. Rockwool or equivalent may be used, it should be fitted above and to each side of the opening to a thickness of at least 100mm.

21. A sloping plate should be fitted above the 150mm diameter sleeve in accordance with IGE Publications DM2 Section 6.1.5 (b).

22. Measure the length required for a 150mm diameter metal wall sleeve, which should fit between the inside wall face and the inside of the outer wall or the rear of the fan box, whichever is the closer to the fire. Cut to length and fit into the 150mm diameter hole. Seal any gaps with a suitable sealant at each end.

Proceed to section 5.5 Fitting the Fan Box

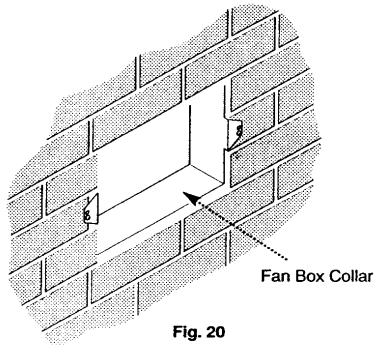

Fig. 20

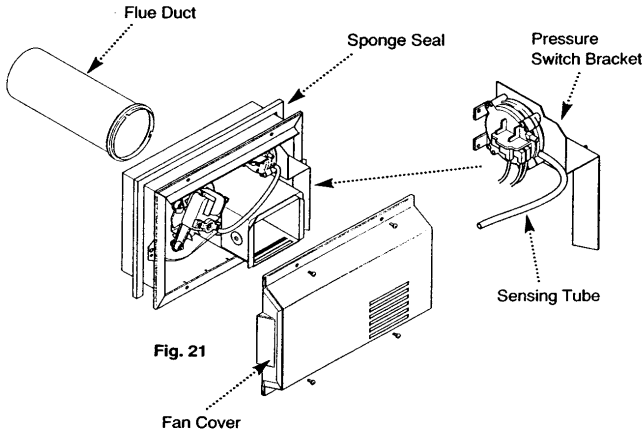

Fig. 21

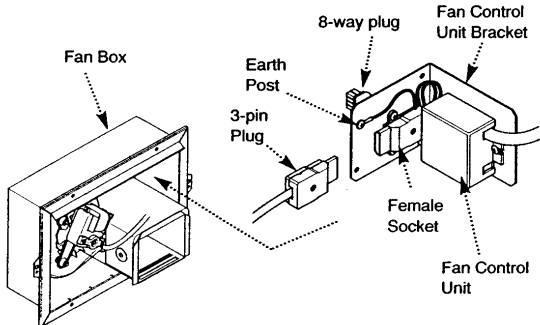

Fig. 22

5.5 Fitting the Fan Box

1. Place the power supply cable and fan to fire harness in their intended positions, passing through the hole in the wall where applicable.
2. Either fit the liner into the recess and pass the fan to fire harness through the hole in the liner, or complete the false chimney breast or surround incorporating the liner as appropriate.
3. Unpack the fan box assembly and undo the screws retaining the brown fan box cover. Take the loose sponge seal from the fan box (Fig. 21).
4. Taking note which is the top, undo the screws securing the fan box to the fan box collar. Slide the collar into the wall (Fig. 20), mark the fixing holes and remove. Below each collar fixing hole also drill a 10mm diameter recess to accept the threaded bushes in the collar.
5. Drill and plug the holes and refit the collar using suitable screws. Any gaps around the edges should be sealed (Fig. 20).
6. Fit the larger diameter flue duct to the rear bayonet fixing on the fan box ensuring it is located correctly and the seal is made (Fig. 21). Depending upon the wall thickness it may be necessary to cut the flue - see Section 5.6.
7. Fit the sponge seal to the 2 sides and top of the fan box mounting face (Fig. 21).
8. Remove the sensing tube from the fan. Undo the screws holding the pressure switch bracket to the fan box. Pull the bracket and switch from the box (Fig. 21).
9. Undo the two screws securing the fan control unit bracket to the fan box and draw the bracket forwards (Fig. 22).
10. Remove the grommet from the slot in the cut-out at the top right of the fan box. Cut the grommet and lit it over the power supply cable.
11. Connect the 3 pin plug to the socket on the fan control unit bracket and re-fit the grommet into slot (Fig. 22).
12. Fit the fan control unit bracket to the fan box using the two screws previously removed.
13. Connect the 8-pin plug from the fan box (Fig. 22) to the 8-pin socket on the harness. Connect the earth lead to the screw on the rear face of the fan box.

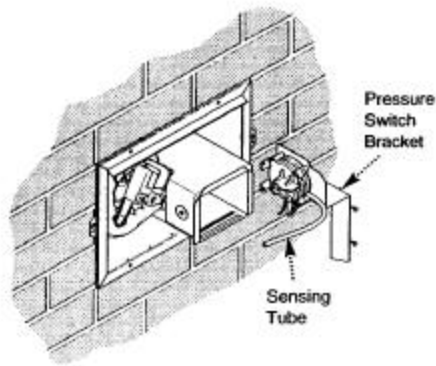

Fig. 23

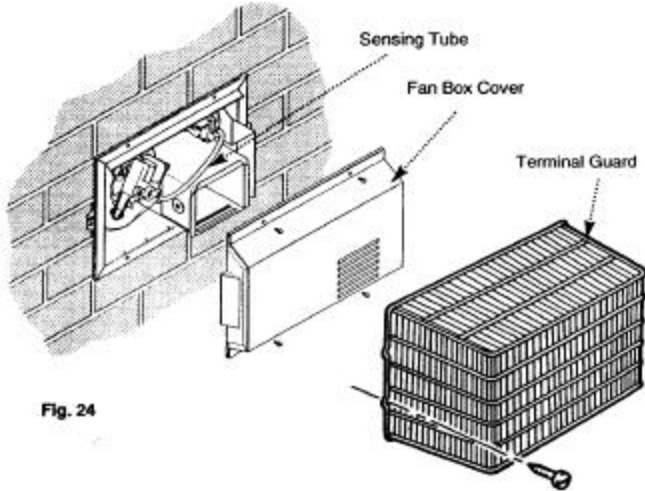

Fig. 24

5.5 Fitting the Fan Box (cont)

14. Locate the fan box and flue assembly in the flue box collar and secure with the screws previously removed and refit the pressure switch bracket (Fig. 23). Reconnect the sensing tube (Fig. 24).

15. Fit the fan box cover to the fan box assembly. **A TERMINAL GUARD IS RECOMMENDED** Baxi Heating Part N° 245770. Position the guard over the fan box. Ensure the guard is equally spaced about the fan box. Mark the fixing positions, drill and plug the holes and secure the guard to wall (Fig. 24).

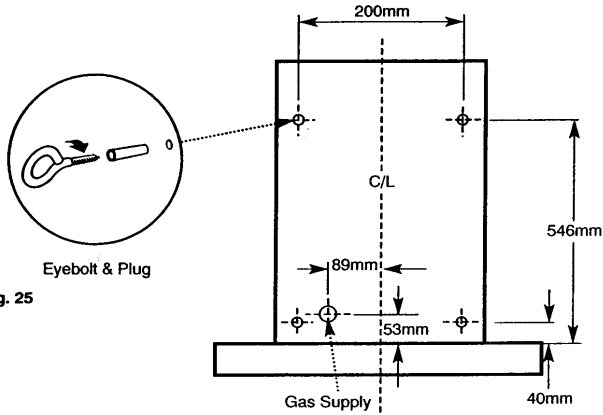

Fig. 25

Fig. 26

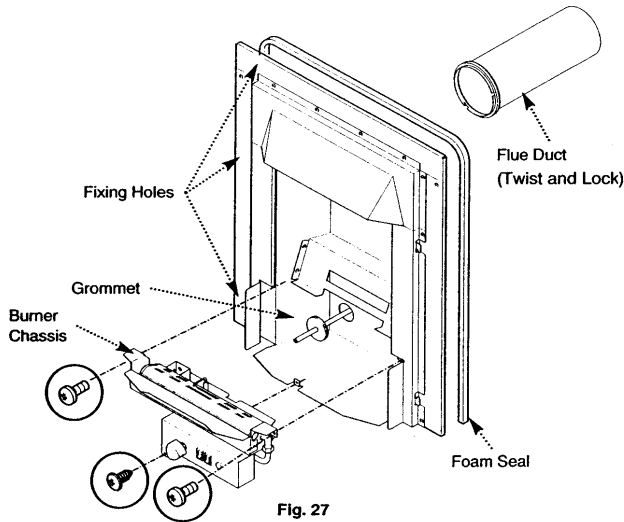

Fig. 27

5.6 Fitting the Fire

1. There are 2 methods of fixing the fire in position, using the eyebolts and cables or simply screwing through the outer fire frame with 4 screws to the wall or surround face.

NOTE: It is recommended that the appliance is screwed to the wall or surround face. The eyebolt and cable method can only be used when the appliance is installed in a false chimney breast or surround.

2. Either mark the wall as shown (Fig. 26) and drill, plug and fit the 4 eyebolts (Fig. 25) or mark the front face of the surround using the fire as a template and drill and plug the 4 holes, 2 at each side. The top 3 holes may also be used if required to ensure a good seal between the fire and the surround (Fig. 27).

3. With the gas supply routed from the rear, mark as shown (Fig. 26) and install the pipework after considering section 3.6 Gas Supply and Connections.

4. Take the foam seal from the kit and remove its backing strip. Fit it to the rear of the fire frame (Fig. 27).

5. Measure the space between the front wall fixing face and the outside wall. Check that the telescopic flue can be set at the appropriate length. Each of the flue ducts may be reduced in length to allow short flues. The overlap must be maintained at a minimum of 30mm.

6. If the wall thickness is at the minimum (300 mm) both flue ducts must be cut to 65mm.

7. Fit the smaller diameter flue duct to the fire outlet, ensuring it is located correctly and the seal is made.

8. Undo the 3 screws retaining the burner chassis to the combustion box sides and base. Withdraw the chassis and place to one side (Fig. 27).

9. Remove and cut the left hand side grommet to accept the gas supply (Fig. 27).

5.6 Fitting the Fire (cont)

SCREW FIXING METHOD

1. Fit the fan box harness lead through the hole at the right hand side of the fire. Do not draw any more of the harness into the fire than is necessary.
2. Position the appliance in front of the fireplace opening. Manoeuvre the appliance backwards into the opening (Fig. 28).
3. Secure the fire in position using suitable screws in the previously drilled and plugged holes.
4. Fit the gas inlet/pressure test point elbow supplied in the kit to the controls feed pipe (Fig. 28a). Connect the 8-way plug to the controls and secure the earth lead to the earth post on the fire. Connect the gas supply to the gas inlet/pressure test point elbow and refit the burner chassis (Fig. 28b).

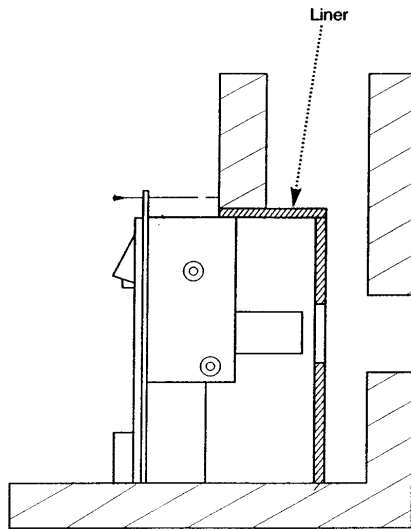
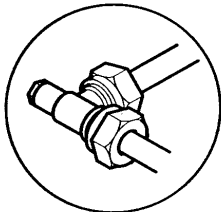

Fig. 28



Gas Inlet Elbow

Fig. 28a

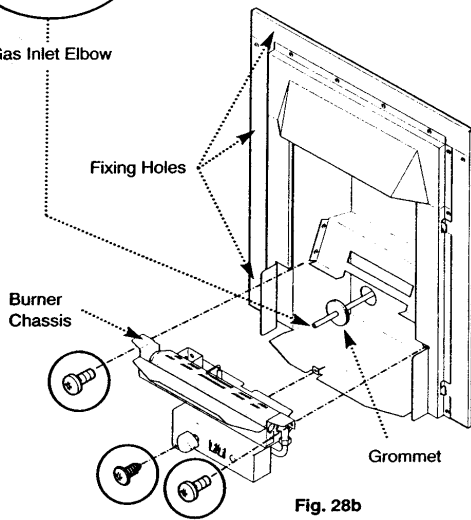
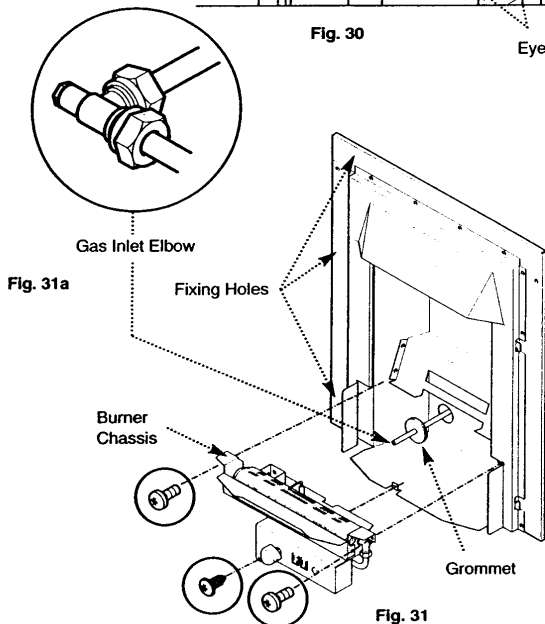
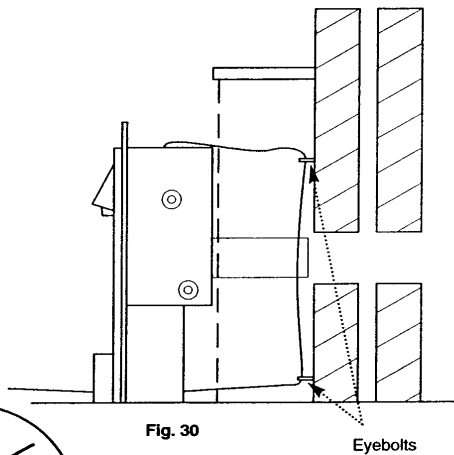
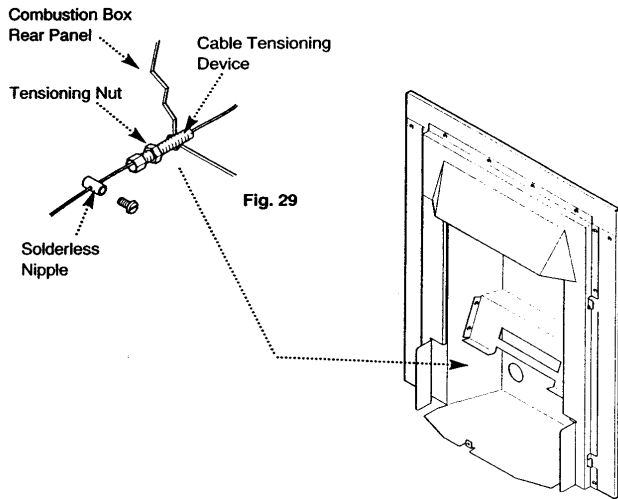

Fig. 28b



5.6 Fitting the Fire (cont)

CABLE TENSION METHOD OF FIXING

1. Engage the tensioning nuts on the threaded shanks of the tensioning devices. Run the nuts down to the hexagonal heads of the tensioning devices (Fig. 29).
2. From the front insert the cable tensioning devices through the combustion box rear panel. The hexagonal heads must be to the inside of the box (Fig. 29).
3. Fit the fan box harness through the hole at the right hand side of the fire. Do not draw any more of the harness into the fire than is necessary.
4. Position the appliance in front of the fireplace opening and insert the cables in the holes in the combustion box rear flange (Fig. 30). Pass the cables through the eyebolts in the fire opening rear face and insert them in the tensioning devices (Fig. 29 & 30). Manoeuvre the appliance backwards into the opening, drawing any slack length of cable through the tensioners.
5. Push the appliance as far back in the opening as possible and pull the cables through the tensioners as tight as possible.
6. Run the solderless nipples down the cables to the tensioners and tighten their securing screws (Fig. 29). As required, take the relevant grommet(s) and slide over the gas and/or electrical supplies. Run the grommet(s) down the pipe and/or cable and insert in the hole in the rear panel (Fig. 31).
7. Using a suitable spanner tighten the tensioning nuts clockwise so that the fire frame surround is pulled up against the wall or surround and the seal is compressed. **DO NOT CUT OFF THE EXCESS CABLE** - coil neatly and secure with tape.
8. Fit the gas inlet/pressure test point elbow supplied in the kit to the controls feed pipe (Fig. 31a). Connect the 8-way plug to the controls and secure the earth lead to the earth post on the fire. Connect the gas supply to the gas inlet/pressure test point elbow and refit the burner chassis (Fig. 31).

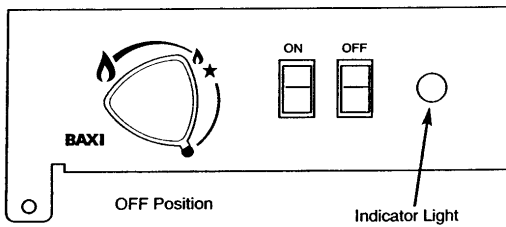
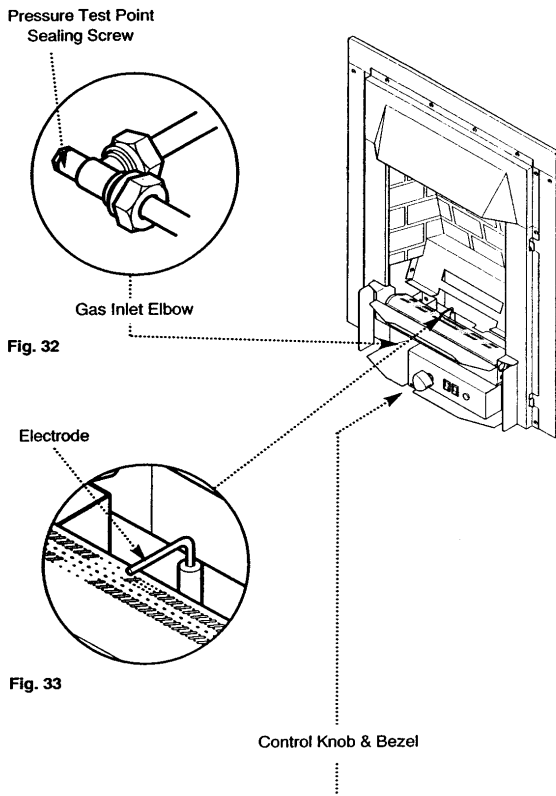

6.1 Checking Gas Soundness

1. Turn on the gas supply and check for gas soundness with leak detection fluid (BS 6891).

6.2 Checking Operation of the Fire

1. Turn off the gas supply. Remove the screw from the pressure test point on the gas inlet elbow and connect a suitable pressure gauge (Fig. 32).
2. Check that the electrode is sparking to the burner (Fig. 33) when the control knob is pushed in and rotated anticlockwise past the ignition position (★) (Fig. 35).
3. Re-set the appliance to the OFF position (●) and turn on the gas and electrical supplies to the appliance.

6.3 Lighting the Fire

1. Press the spring loaded fan ON switch to start the fan. The switch will return to its' original position when released. The red indicator light will go out when the air pressure switch has proven the fan is running
2. Purge the air from the appliance by depressing the control knob and rotating slowly anticlockwise through the ignition position (★). When the electrode sparks the burner will light.
3. Once the burner has lit continue to push in the control knob for 15 seconds allowing the magnetic safety valve to operate.
4. If the burner fails to light repeat step 2 and 3 above.
5. With the burner alight, depress the control knob slightly and rotate anticlockwise to the maximum output position (🔥) (Fig. 37).
6. Release the knob and check the gas inlet pressure is 20 mbar ± 1.0 mbar.
7. Turn the control knob back to the OFF (●) position (Fig. 34). Disconnect the pressure gauge and re-fit the screw to the pressure test point ensuring a gas tight seal.
8. Press the OFF switch to turn the fan off. The switch will return to its' original position when released.

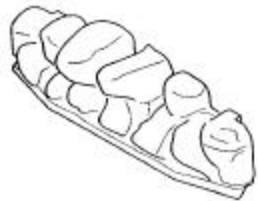

Front Coal Moulding



Rear Coal Moulding

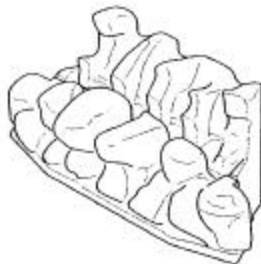

Front and Rear Arrangement

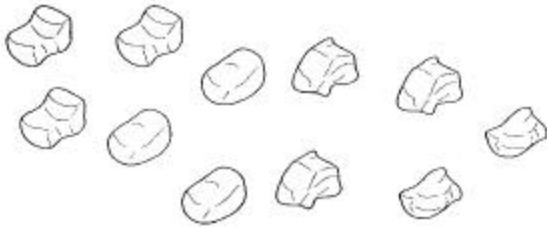

Loose Coals



Layout of Coalbed

7.1 Identification

It is Important that all the firebed components are used and arranged as shown In order to achieve the desired flame picture. Ensure all firebed components are present and Identified prior to Installation.

1. Remove the coals, and front and rear coal mouldings from their packaging and place them on a newspaper or similar to prevent soiling furnishings.

CAUTION: The coals are extremely fragile and must be handled accordingly. To avoid soiling ones hands, gloves should be worn and any inhalation of the dust should be avoided. Keep the coals away from children at all times. Never use coals other than those supplied or Genuine Baxi Spare Parts. Never put additional coals on the fire. Please read Section 1.2 Important Information

2. The side and back brick effect insulation panels can be reversed to offer a plain effect for the customer. To reverse this brick effect remove the left and right hand black sheet metal retaining pieces. Carefully remove the three insulation panels and reassemble with the plain effect on display. Refit the retaining panels taking care not to damage the paint and insulation panels.

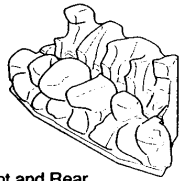

Front and Rear Coalbed Arrangement

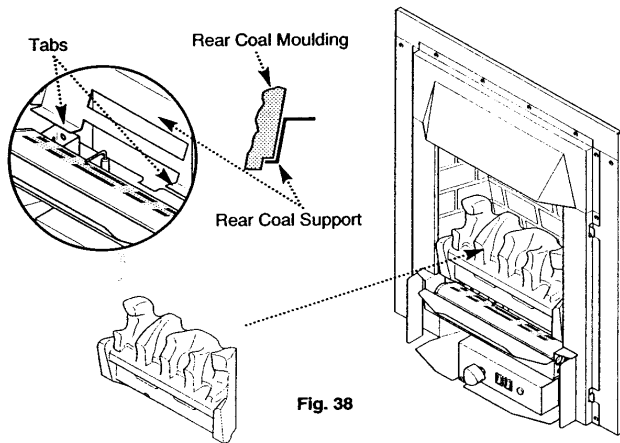

Fig. 38

Rear Coal Moulding

7.2 Arranging the Coalbed

NOTE: It is important for the safe operation of the appliance that the front and rear coal mouldings are correctly located and in accordance with these instructions.

1. Carefully position the rear coal moulding into the rear of the fire. The undercut in the base of the moulding should rest on the tabs of the rear coal support. The back face of the moulding should sit on the rear coal support. Care should be taken that the rear coal moulding does not fall forward at this stage.

2. Carefully position the front coal moulding on the burner tray with the front edge of the moulding behind the lip. The rear edge of the moulding should then rest on the front of the burner (Fig. 39).

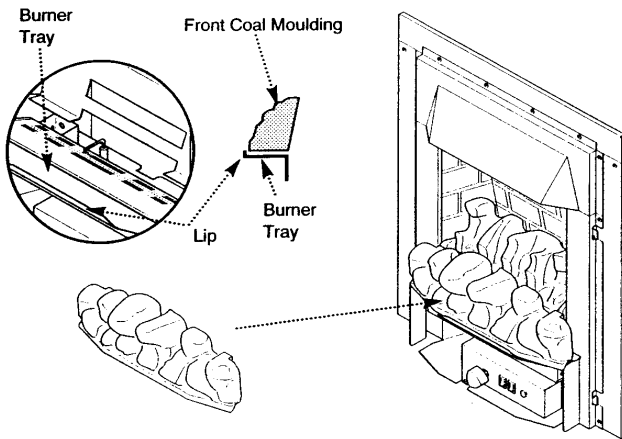

Fig. 39

Front Coal Moulding

7.3 Arranging the Loose Coals

NOTE: Do not allow any of the coals to fall into the gap between the front and rear coal mouldings.

1. Take 2 coals and place on the outer edges of the front coal moulding (Fig. 40).
2. Take 4 coals and place as shown in Fig. 41 bridging the front and the rear coal mouldings. Ensure that the flat faces on these coals face downward.
3. Take the 5 remaining coals and place as shown in Fig. 42 positioned in the gaps between the coal mouldings and loose coals.

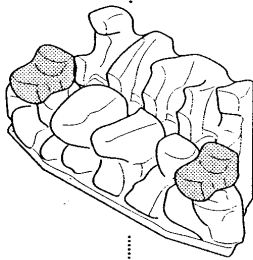
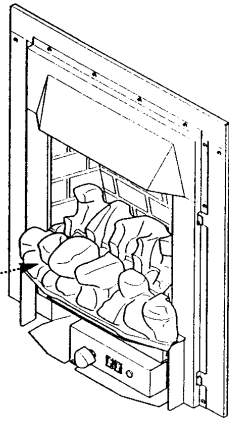

Fig. 40

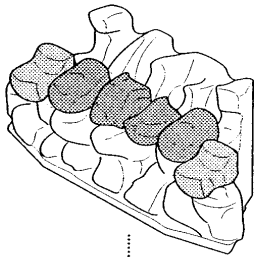

Fig. 41

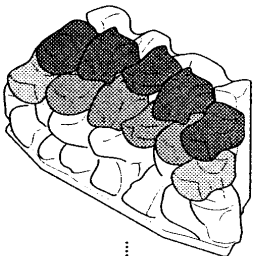
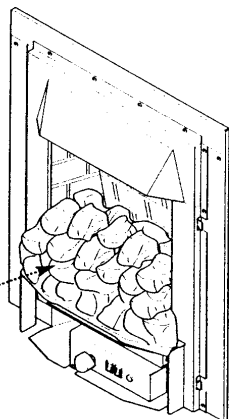
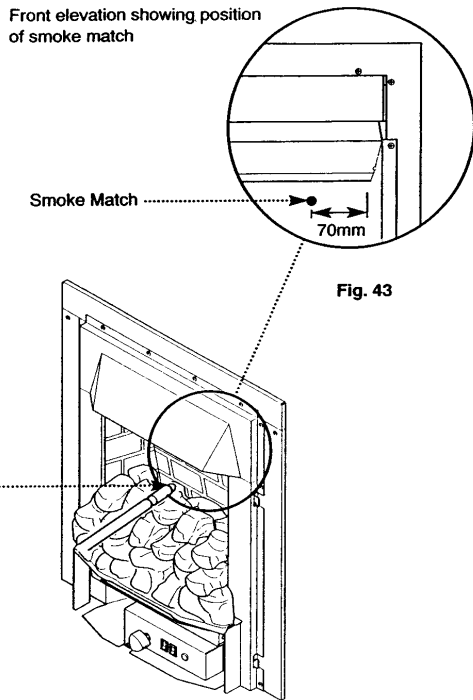

Fig. 42





Insert the smoke match 20mm in from the front edge of the canopy and 70mm in from the right hand side.

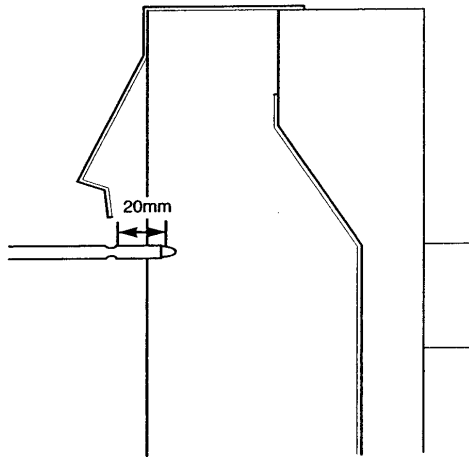

Fig. 44

8.1 Checking for Spillage

CAUTION-Whilst checking for spillage care must be taken to avoid touching hot panels.

1. Before starting the test close all doors and windows.
2. Operate the fire from cold at maximum input.
3. After approximately five minutes check for spillage.
4. Fit a smoke match into a holder, and position with the holder held horizontally projecting 20mm under the lip of the canopy bottom and 70mm from the start of the straight section on one side of the fire (Fig. 43 & 44).
5. If spillage is evident leave the fire operating for a further ten minutes and repeat test.
6. If test is successful repeat with any extractor fan operating and connecting doors open to create the worst likely operating conditions.
7. If spillage still occurs and the problem cannot be rectified the fire must be isolated until the problem is resolved.

NOTE: It is important that the smoke match is positioned accurately for the test as an incorrectly positioned match may result in smoke being picked up by convected air currents, indicating spillage.

9.1 Fitting the Trim and Fender (Fig. 45)

1. Carefully remove the trim and fender from their packaging.
2. Align the trim with the fire outer frame. The trim has four keyhole type cutouts on the inside edge which locate on the tabs on the black side trims.
3. Place the fender assembly centrally between the legs of the trim and push it back as far as possible.
4. In a similar manner place the controls access door centrally in the fender opening and push back as far as possible.

9.2 Informing the User

1. These instructions and the Users Operating Instructions should be handed to the customer. At the same time the customer should be shown how to operate the fire safely and efficiently.
2. The need for annual servicing should be emphasised and the returning of the guarantee card advised.

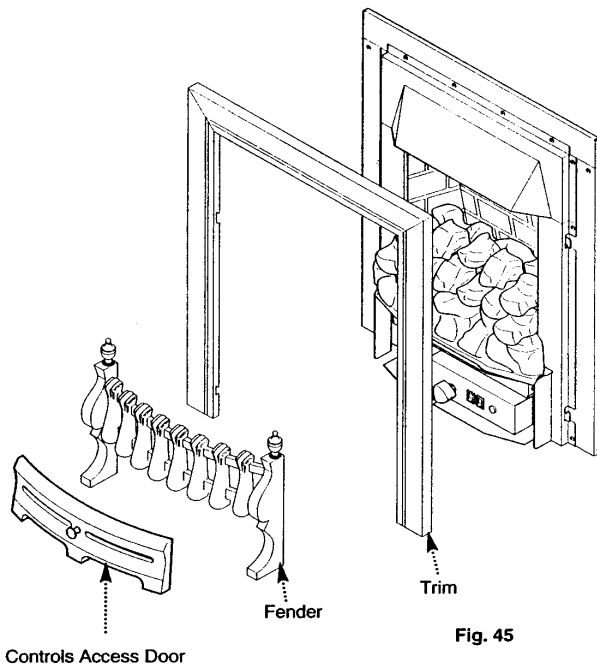

Fig. 45

10.1 Maintenance

IMPORTANT: It is possible that some soot may be deposited on the coals after use. This is acceptable providing it is not allowed to accumulate.

CAUTION: The coals are extremely fragile and must be handled accordingly. To avoid soiling ones hands, gloves should be worn and any inhalation of the dust should be avoided. Keep the coals away from children at all times. Never use coals other than those supplied or Genuine Baxi Spare Parts. Never put additional coals on the fire. Please read Section 1.2 Important Information

1. Servicing should be carried out regularly by a competent person in accordance with the relevant regulations, to ensure the safe and correct operation of the appliance.
2. Before commencing any service or replacement of parts, turn off the gas supply to the fire and ensure that the fire is cold, and isolate the electrical supply.
3. After servicing, check for gas soundness.
4. When ordering spare parts please quote appliance name and serial number. These can be found on the data badge which is located by removing the controls access door, the badge is on the base plate of the appliance.
5. If excessive soot has accumulated check to establish the cause.
6. The loose coals may be removed for cleaning. The coals are delicate and should be handled carefully. Gently brush with a soft brush to remove dust or deposits.
7. Examine the coals for signs of cracking and replace if necessary.

IMPORTANT: See coal layout procedure (Section 7.0 Arranging the Coals) before attempting to replace coals which should only be replaced as a complete set with no extra coals added.

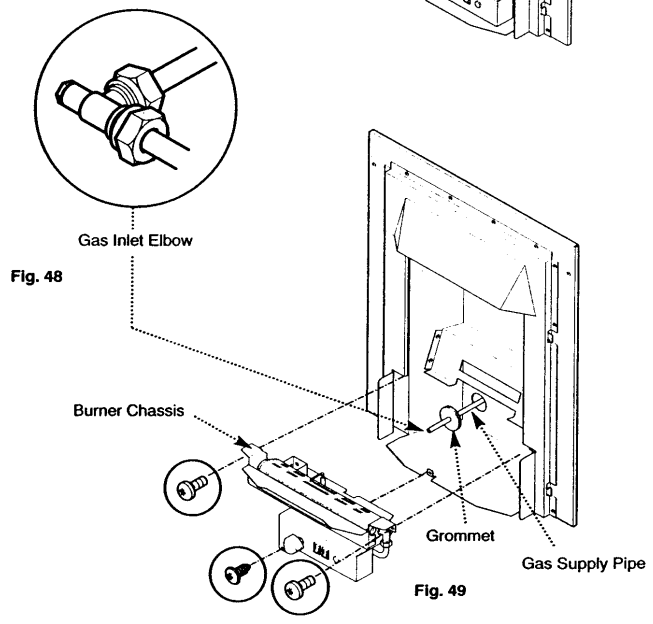
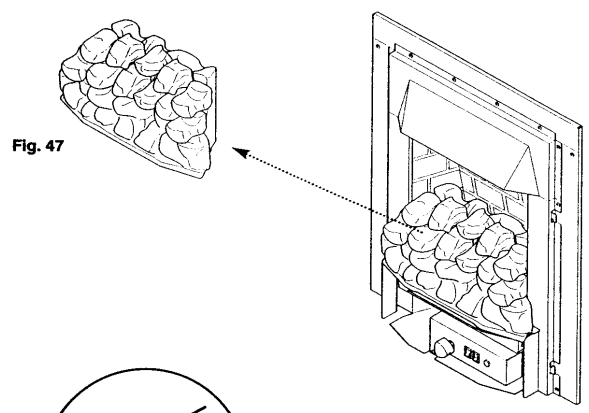
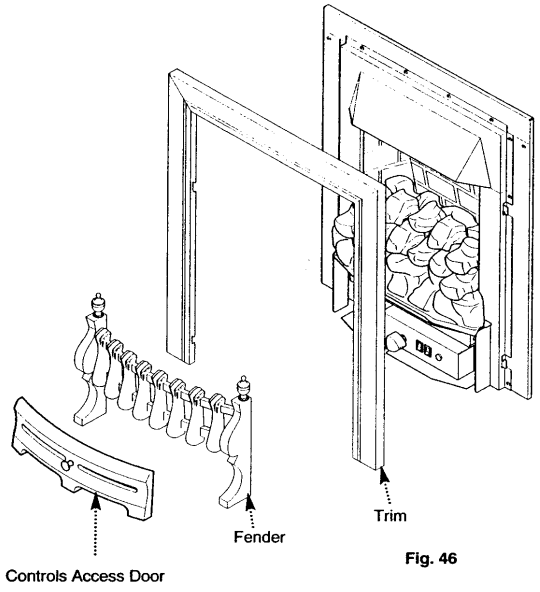

10.2 Preparation

1. For reasons of safety and economy it is important to service the fire annually.

WARNING: Isolate the gas and electrical supplies to the appliance before servicing.

2. Remove the controls access door and fender assembly (Fig. 46).

3. Remove the trim (Fig. 46).

4. Carefully remove all the loose coals, and the front and rear coal mouldings (Fig. 47).

5. Undo the gas supply at the disconnecting union. If necessary remove any pipework between the union and inlet elbow (Fig. 48).

6. Undo the three screws retaining the burner and controls to the combustion box sides and combustion box base. Withdraw the burner and controls from the fire (Fig. 49).

10.3 Cleaning the Burner and Injectors

1. Undo the screw retaining the spark electrode to the burner tray (Fig. 50).
2. Undo the screw retaining the burner to the burner tray (Fig. 51).
3. Slide the burner to the left to disengage from the injector. Rotate the electrode slightly and lift the burner out of the tray.
4. Using a soft brush remove any dirt from the burner and ensure all ports are free from obstruction.
5. Undo the union nut connecting the gas pipe to the injector (Fig. 50).
6. Undo the injector locknut and remove the injector from the burner tray by disengaging the gas pipe from the injector (Fig. 52).
7. Examine and clean the injector. Do not use any hard tools such as pins or wire. Renew if necessary (Fig. 52).
8. When retightening the gas feed pipe nut, hold the injector body with a suitable spanner to prevent misalignment of the injector.
9. Reassemble in reverse order.

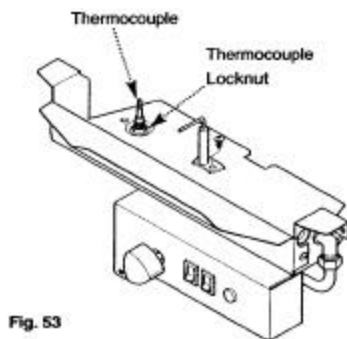
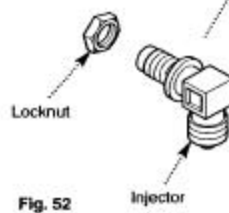
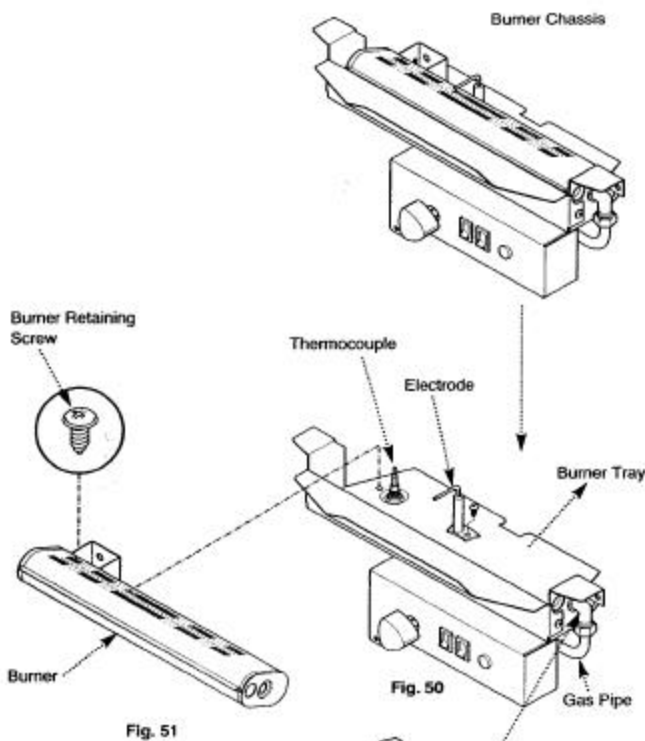

10.4 Cleaning the Thermocouple (Fig. 53)

NOTE: No attempt should be made to clean the device using any hard tools, including pins or wire.
WARNING: The thermocouple assembly must not be adjusted in any way, or be altered so that it will not operate or be bypassed.

1. Ensure that the burner aeration hole is free from lint, debris etc.
2. Ensure that the thermocouple locknut is tight and there is no damage to the thermocouple lead.
3. The thermocouple can be changed as an individual component. (See section 11.0 Changing Components).
4. Only use a Genuine Baxi Spare Part.

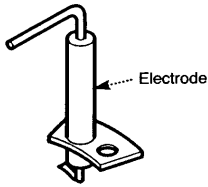

Fig. 54

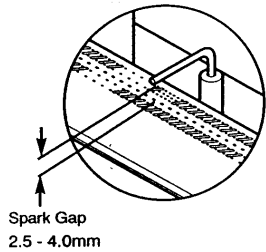

Fig. 55

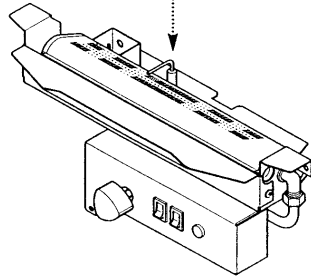

Fig. 56

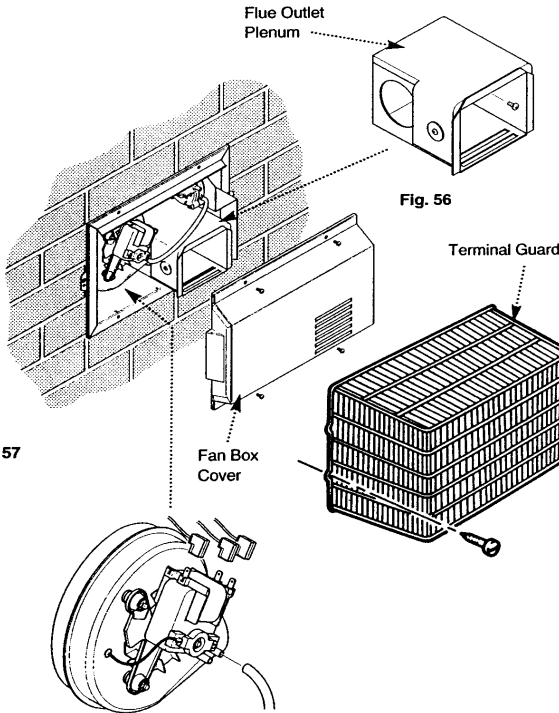

Fig. 57

Fig. 58 Rotate fan assembly approximately 20° anti-clockwise to disengage

10.5 Cleaning the Electrode (Figs. 54 & 55)

1. Check for any signs of cracking or other damage to the ceramic.
2. Clean the electrode wire if necessary.
3. Upon re-assembly check the spark gap is 2.5-4.0mm.

10.6 Cleaning the Fan

1. From outside remove the terminal guard and fan box cover (Fig. 57).
2. Undo the screws holding the fan outlet plenum to the fan box. Manoeuvre the plenum from the box taking care not to damage the rear gasket (Fig. 56). Note the position of the three wires to the fan and remove them. Disconnect the sensing tube from the fan (Fig. 58).
3. Rotate the complete fan approximately 20° anti-clockwise to disengage it from the fan box. Draw the fan clear of the box (Fig. 58).
4. Ensure the flue duct is clean and free from debris.
5. Carefully clean any deposits from the fan impellor with a soft brush.
6. When reassembling ensure that the rear gasket is in position behind the flue outlet plenum.

10.7 Completing Servicing

1. Clean any dirt and debris from the appliance combustion box and installation.
2. Reassemble all components in reverse order of dismantling and recommission the fire.

11.1 Changing Components

WARNING: Isolate the gas and electrical supplies to the appliance before changing any components.

1. Remove the controls access door and fender assembly (Fig 59).
2. Carefully remove all the loose coals and the front and rear coal mouldings.

CAUTION: The coals are extremely fragile and must be handled accordingly. To avoid soiling ones hands, gloves should be worn and any inhalation of the dust should be avoided. Keep the coals away from children at all times. Never use coals other than those supplied or Genuine Baxi Spare Parts. Never put additional coals on the fire. Please read section 1.2 Important Information

NOTE: After changing any components carry out checks for gas soundness

1. Pull and lift the trim away from the fire outer frame. It is attached by the keyways in the inside edge of the trim.

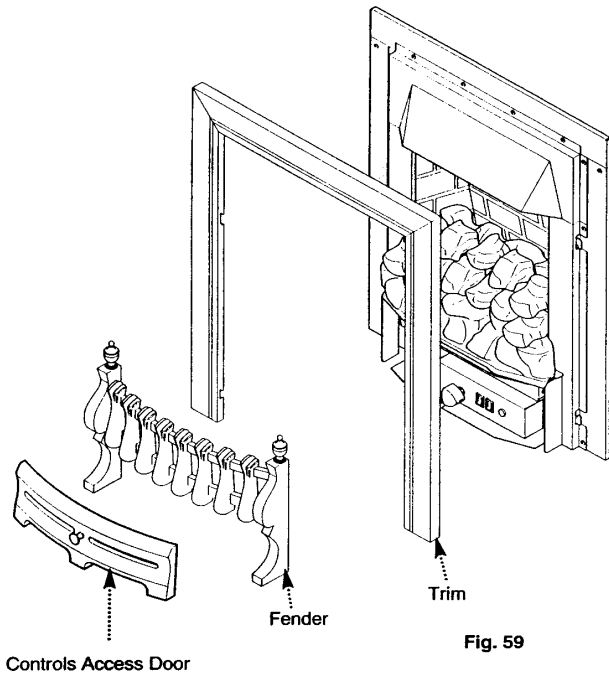

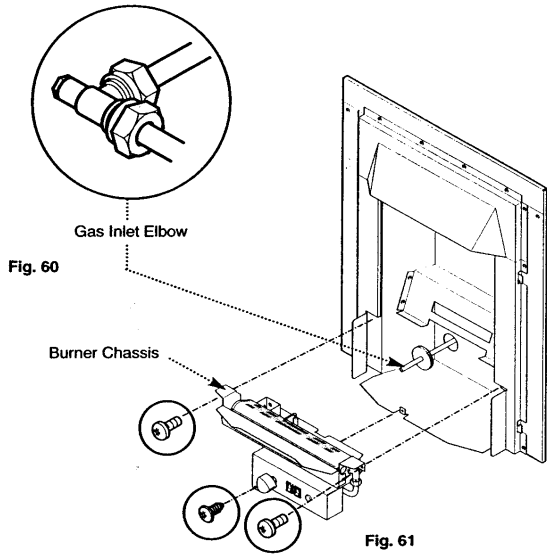

11.2 Removal of Controls / Burner Chassis Assembly

1. If any of the controls components are to be renewed the burner chassis assembly must be removed from the appliance.
2. Undo the gas supply at the disconnecting union. If necessary remove any pipework between the union and inlet elbow (Fig. 60).
3. Undo the three screws retaining the burner chassis assembly to the combustion box sides and combustion box base. Withdraw the burner chassis assembly (Fig. 61).

11.3 Burner

1. Undo the screw retaining the spark electrode to the burner tray (Fig. 62).
2. Undo the screw retaining the burner to the burner tray (Fig. 63).
3. Slide the burner to the left to disengage from the injector. Rotate the electrode and lift clear
4. Replace with new burner and re-assemble in reverse order.

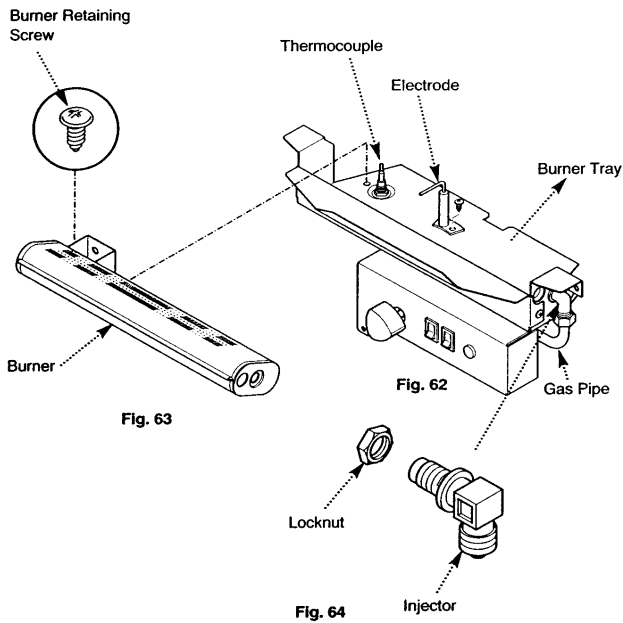

11.4 Injector (Fig. 64)

1. Remove the burner as described in 11.3 and undo the union nut connecting the gas feed pipe to the injector (Fig. 62).
2. Remove the locknut retaining the injector to the controls frame and withdraw the injector by disengaging the gas pipe from the injector.
3. Fit the new injector. When retightening the gas feed pipe nut, hold the injector body with a suitable spanner to prevent misalignment of the injector.
4. Reassemble in reverse order.

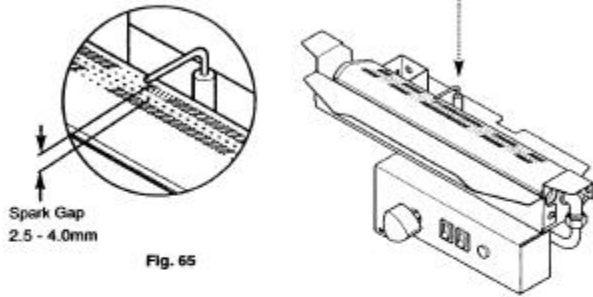
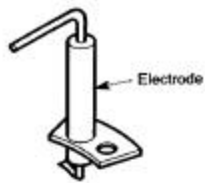

11.5 Electrode (Fig. 65)

1. Disconnect the electrode lead from the tag at the base of the electrode.
2. Undo the screw retaining the electrode to the burner tray and withdraw.
3. Fit the new electrode and re-assemble in reverse order. Check that the spark gap is between 2.5mm and 4.0mm.

11.6 Thermocouple

1. Remove the burner as described in section 11.3.
2. Undo and remove the locknut holding the thermocouple to the burner tray (Fig. 66).
3. Undo the thermocouple nut from the rear of the gas valve (Fig. 67) and remove the thermocouple from the burner tray.
4. Carefully bend the new thermocouple to the shape of the original and reassemble in reverse order of dismantling.

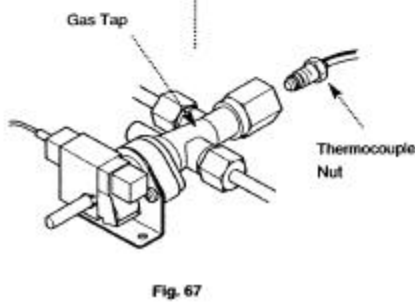
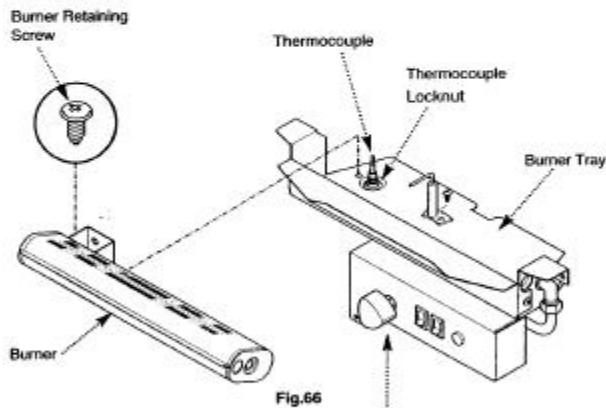

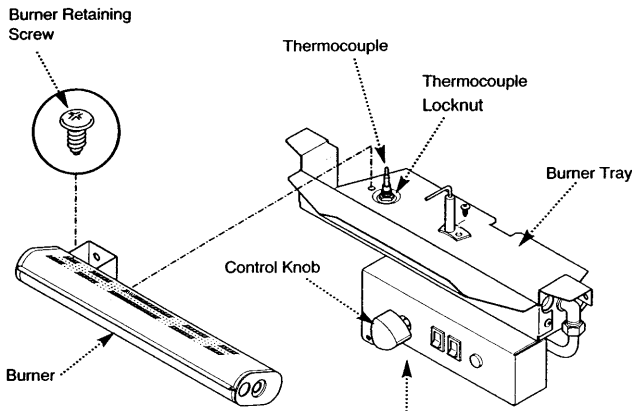

Fig. 68

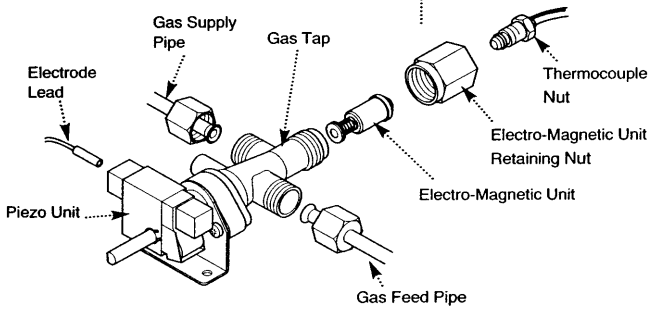

Fig.69

11.7 Gas Tap and Piezo Unit (Fig. 69)

1. Remove the burner as described in section 11.3.
2. Undo the thermocouple nut from the rear of the gas valve.
3. Undo the union nuts connecting the gas inlet pipe and the gas feed pipe to the injector from the body of the gas valve.
4. Disconnect the electrode lead from the piezo unit.
5. Pull away the control knob (Fig. 68) from the gas valve shaft.
6. Undo the two screws retaining the gas valve and piezo unit to the control marking plate and remove the unit.
7. Fit the new unit and reassemble in reverse order.

11.8 Electro-Magnetic Unit (Fig. 69)

1. Undo the thermocouple nut from base of the tap.
2. Undo the magnetic unit retaining nut and withdraw the magnetic unit.
3. Fit the new magnetic unit and reassemble in reverse order.

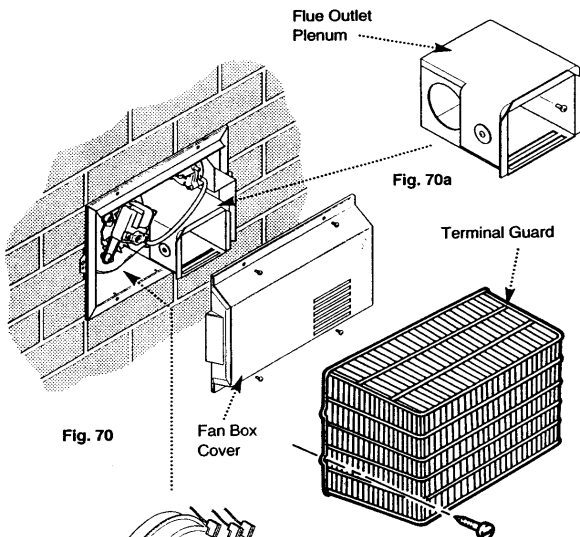

11.9 Fan (Fig. 70 & 71)

1. From outside remove the terminal guard and fan box cover.
2. Undo the screw holding the fan outlet plenum to the fan box. Manoeuvre the plenum from the box taking care not to damage the rear gasket (Fig. 70a). Note the position of the three wires to the fan and remove them. Disconnect the sensing tube from the fan.
3. Rotate the complete fan approximately 20° anti-clockwise to disengage it from the fan box. Lift the fan clear of the box.
4. Fit the new fan and reassemble in reverse order. When reassembling, ensure that the rear gasket is in position behind the plenum.

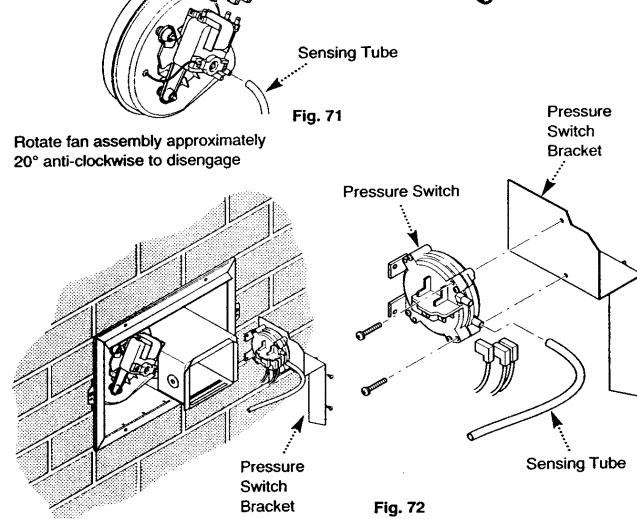

11.10 Air Pressure Switch (Fig. 72)

1. From outside remove the fan box cover, 4 screws.
2. Remove the sensing tube from the fan. Undo the screws holding the pressure switch bracket to the fan box. Pull the bracket and switch from the box.
3. Note the position of the three wires to the pressure switch and remove them. Undo the two screws retaining the switch to the bracket and remove the switch.
4. Fit the new switch and connect the wires and sensing tube as previously noted.

11.11 Solenoid Valve (Fig. 73)

1. Remove the plug connecting the solenoid valve, noting the position of the solenoid valve.
2. Undo the two union joints, one at each side of the valve and remove the valve.
3. Renew the valve and reassemble in reverse order ensuring it is fitted the correct way round and in the same orientation as the original.

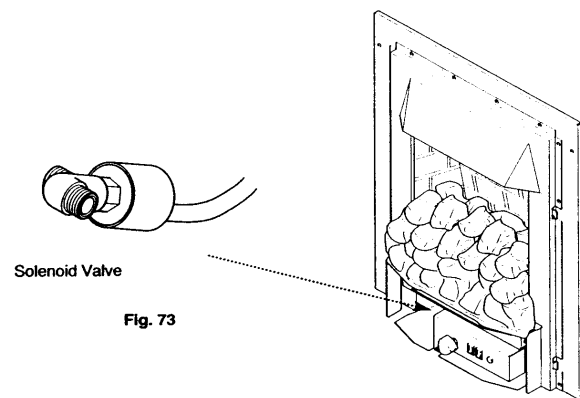

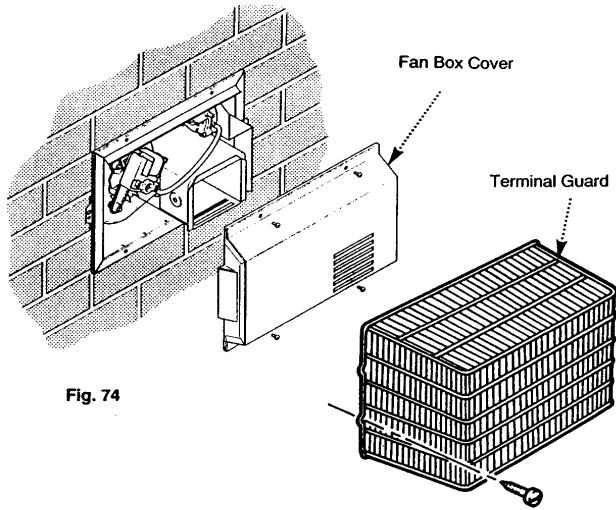

Fig. 74

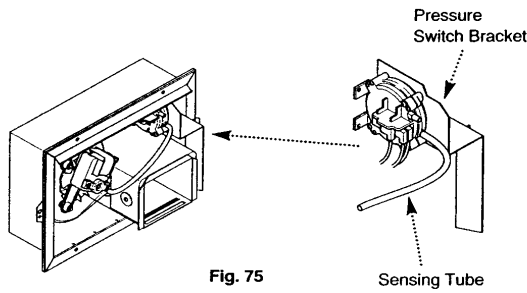

Fig. 75

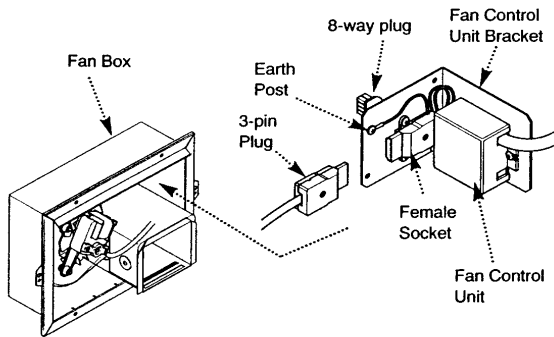

Fig. 76

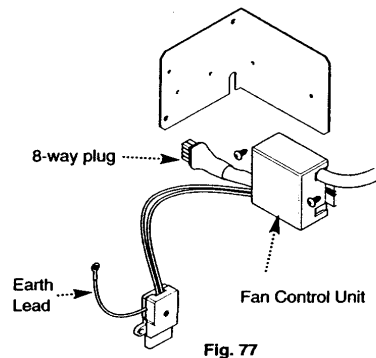
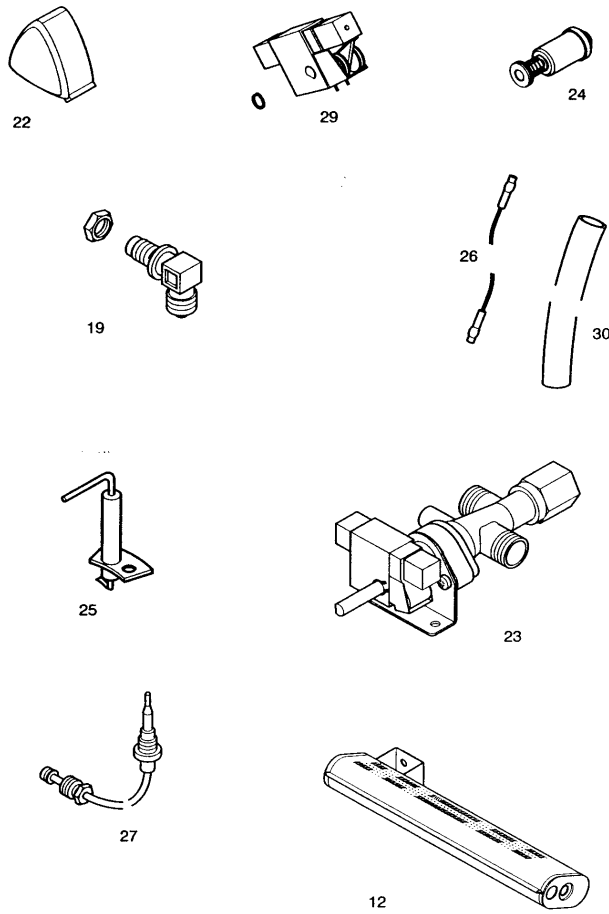

Fig. 77

11.12 Fan Control Unit

1. From outside remove the terminal guard and fan box cover (Fig. 74).
2. Undo the four screws holding the fan box to the fan box collar and draw the fan box out. Disconnect the 8-way plug and undo the earth screw from the rear of the fan box. Completely remove the fan box from the wall.
3. Undo the screws securing the pressure switch bracket to the fan box and draw the bracket forwards (Fig. 75).
4. Pull the sensing tube off the fan. Note the position of the wires on the fan and pressure switch and remove them. Place the pressure switch to one side (Fig. 75).
5. Undo the screws securing the fan control unit bracket to the fan box. Disconnect the 3-pin plug and socket and draw the bracket forwards (Fig. 76).
6. Undo the earth screw from the bracket and remove the screws retaining the plug and fan control unit to the bracket (Figs. 76 & 77).
7. Fit the new fan control unit (Fig. 77) and reassembly in reverse order.

12.1 Short Parts List



Key No.	G.C. No.	Description	Manufacturers Part No.
40	E25 213	Front Coal Moulding	245256
41	E25 214	Rear Coal Moulding	245257
44	E25 217	Loose Coals	245260
22	E25 198	Control Knob	245239
23	E25 199	Gas Tap	245240
24	E01 617	Mag Unit	239413
29	E01 353	Piezo Unit	239289
26	378 924	Electrode Lead	236493
30	E25 203	HT Sleeve	245247
19	E25 196	Injector	245237
12	E24 110	Burner	245229
25	E25 200	Electrode	245242
27	E25 201	Thermocouple	245244
48	E25 221	Fan	245261
51	E25 223	Fan Control Box Unit	245263
49	E25 222	Air Pressure Switch	245262
53	E25 266	Solenoid valve	245265

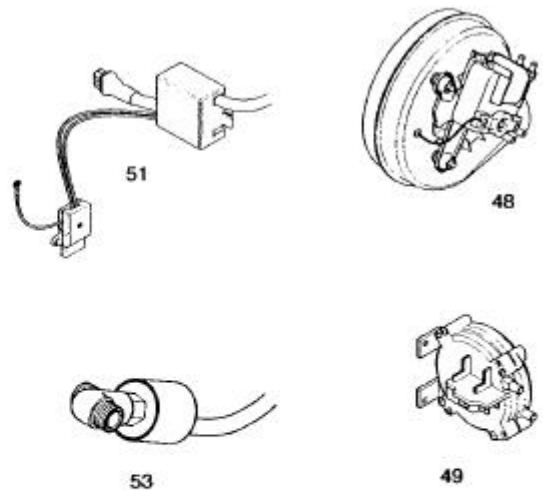
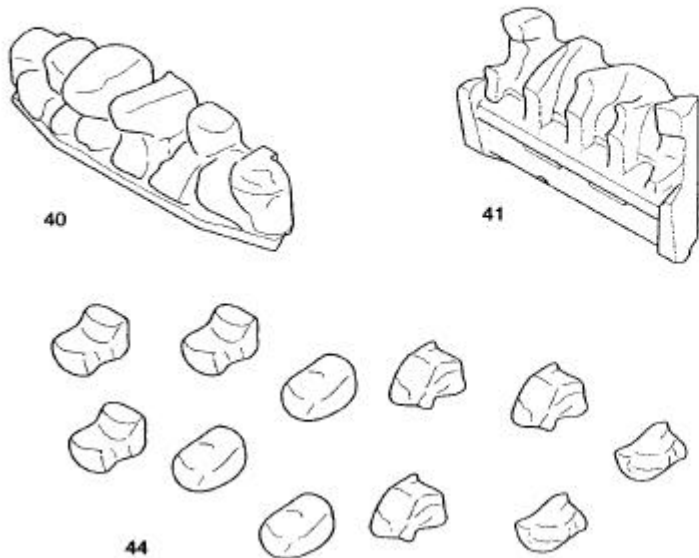

[Click here for Helplines](#)