

Wonderfire

I N S T A L L E R G U I D E

For

MODEL BR517R

(G.C. 32-032-11)

**Rear Fan Flued Inset
Gas Fire**

with

LINCOLN

Front

Please keep in a safe place for future reference

Please leave this Installer Guide with the user

As supplied, this appliance is for use with natural gas (G20)

When converted using Wonderfire conversion kit no.591149 this appliance is for use with propane gas (G31)

This appliance is for use in the United Kingdom (GB) and the Republic of Ireland (IE) only.

C U S T O M E R C A R E

This Installer Guide gives sufficient details to enable the appliance to be installed and maintained. If further information is required our Wonderfire service department will be pleased to help.

**Please phone us on 0121 386 6203
In the republic of Ireland call 353 183 75114**

C O N T E N T S



	Page
Appliance data	4
General installation requirements	5
Contents of pack	9
Preparing appliance for installation	10
Wall preparation	11
• General	11
• Brick etc. building. Appliance in front of wall	11
• Brick etc. building. Appliance recessed in wall	12
• Timber frame building. Appliance in front of wall	14
Electrical installation	16
Installing appliance	17
Electrical tests	18
Installing the cast iron firefront	19
Terminal guard & gas supply installation	20
Ceramic coals & wall installation	22
Full operating checks	23
• Control settings check	23
• Spillage check	24
Final review	25
Servicing & parts replacement	26
• Burner plaques replacement	26
• Cast front surround removal	27
• Pilot unit removal	27
• Burner unit complete removal	28
• Gas tap/F.S.D. & solenoid assembly removal	28
• Piezo generator removal	28
• Main burner injector removal	28
• Fan switch removal	28
• Electrical control components access	29
• Distribution block removal	29
• Air pressure switch removal	29
• Fan removal	30
Short list of spares	31

PART 1: APPLIANCE DATA

This product uses fuel effect pieces, burner back wall and gaskets containing Refractory Ceramic Fibres (RCF), which are man-made vitreous silicate fibres. Excessive exposure to these materials may cause temporary irritation to eyes, skin and respiratory tract. Consequently, it makes sense to take care when handling these articles to ensure that the release of dust is kept to a minimum. To ensure that the release of fibres from these RCF articles is kept to a minimum, during installation and servicing we recommend that you use a HEPA filtered vacuum to remove any dust and soot accumulated in and around the fire before and after working on the fire. When replacing these articles we recommend that the replaced items are not broken up, but are sealed within a heavy duty polythene bag, clearly labelled as RCF waste. This is not classified as “hazardous waste” and may be disposed of at a tipping site licensed for the disposal of industrial waste. Protective clothing is not required when handling these articles, but we recommend you follow the normal hygiene rules of not smoking, eating or drinking in the work area and always wash your hands before eating or drinking.

This appliance does not contain any component manufactured from asbestos or asbestos related products.

The appliance data label and wiring diagram are on a tie below the burner and are visible when the bottom front cover is removed.

Gas	Natural (G20)	Propane (G31)*
Inlet Pressure	20mbar	37mbar
Input - Max. (Gross)	6.0kW (20,500Btu/h)	6.1kW (20,800Btu/h)
Input - Min. (Gross)	2.2kW (7,500Btu/h)	3.6kW (12,280Btu/h)
Output - Max.	3.12kW (10,600Btu/h)	3.6kW (12,280Btu/h)
Output - Min	1.1kW (3,750Btu/h)	1.8kW (6,140Btu/h)
Burner Test Pressure (Cold)	18.2±0.75mbar (7.3±0.3in w.g.)	35.6±0.75mbar (14.3±0.3in w.g.)
Gas Connection	8mm pipe	8mm pipe
Burner Injector	Bray Cat. 18 Size 360	Bray Cat. 18 Size 170
Pilot & Atmosphere Sensing Device	SIT Ref. OP9044	SIT Ref. OPLPG9222
Ignition	Piezo Electric. Integral with Gas Tap	Piezo Electric. Integral with Gas Tap
Aeration	Non-adjustable	Non-adjustable
Electrical supply	230V ~ 50Hz AC	230V ~ 50Hz AC
Fan motor rating	55W	55W
Fuse rating	3A 	3A 

*When converted using kit 591149

PART 2 : GENERAL INSTALLATION REQUIREMENTS

2.1 The installation must be in accordance with these instructions. For the user's protection, in the United Kingdom it is the law that all gas appliances are installed by competent persons in accordance with the current edition of the Gas Safety (Installation and Use) Regulations. Failure to install the appliance correctly could lead to prosecution. The Council for the Registration of Gas Installers (CORGI) requires its members to work to recognised standards.

In the United Kingdom, all electrical supply installation must be installed in accordance with the current edition of the IEE Wiring Regulations (BS7671).

In the United Kingdom the installation must also be in accordance with:

- a) All the relevant parts of local regulations.
- b) The current edition of the Building Regulations issued by the Department of the Environment and the Welsh Office or the Building Standards (Scotland) Regulations issued by the Scottish Development Department.
- c) All relevant codes of practice.
- d) The relevant parts of the current editions of the following British Standards:-
 - BS 5440 Part 1
 - BS 5871 Part 2
 - BS 6891

In the republic of Ireland the installation must also conform with:

- a) The current edition of IS 813.
- b) All relevant national and local rules in force.
- c) The current ETCI National Rules for Electrical Installation.

2.2 Electrical isolation of the unit should be by means of a switched fuse spur that should be readily accessible to the user, easily identifiable and preferably sited adjacent to the appliance. It should only connect this appliance.

2.3 This fire is a fan flued appliance for installation on an outward facing wall of a conventional home which does not have a purpose built flue or chimney.

2.3.1 As supplied, the appliance is suitable for homes constructed of brick, stone, etc. For homes constructed of brick, stone, etc. the appliance can be installed into walls up to a maximum thickness as shown below.

If the convection box is recessed into the wall: 413mm (16¼ in) max.

If the convection box is in front of the finished wall surface: 305mm (12in) max.

These dimensions are from the finished internal wall surface (including any surround material) to the external wall surface.

2.3.2 For timber framed buildings, the optional clearance box part no. 517TFK must be installed. For timber framed buildings, the appliance is suitable for walls up to 292mm (11½ ") maximum thickness measured from the external wall surface to the internal plasterboard (or similar) wall surface.

Installation to a timber framed building should be in accordance with the relevant sections of The Institute of Gas Engineers publication IGE/UP/7 "Gas installations in timber frame buildings". **Please note that advice should**

be sought before installing in a timber frame building since the alterations required may nullify any NHBC cover relating to the property. If in doubt, guidance should be requested from your local authority planning or building department.

2.4 This appliance must be mounted with a non-combustible hearth (n.b conglomerate marble hearths are considered as non-combustible). The fire box and fan box must be mounted on a non-combustible surface. The hearth must project at least 345mm forward of the convection box front and be at least 620mm wide (See illustrations in “wall preparation” section. The hearth material must be at least 12mm thick. The periphery of the hearth (or fender) should be at least 50mm above floor level to discourage the placing of carpets or rugs over it. For timber framed buildings the hearth must be at least 50mm deep over all its area so that the clearance box can be satisfactorily installed.

The surface of the hearth must be sufficiently flat to enable the bottom of the front surround, the burner bracket and the bottom front cover casting to be aligned horizontally. Any excessive unevenness (uneven tiles, Cotswold stone, etc.) should be rectified.

The appliance must not stand on combustible materials or carpets.

2.5 The appliance must not be fitted directly against a combustible wall.

If the appliance is to be fitted against a wall with combustible cladding or skirting board, such materials must be removed from the area covered by the metal outer surround of the appliance. We suggest that the actual surround is used as a template to mark the area for combustible cladding removal.

The appliance can be fitted to a purpose made proprietary class “O” 150°C surround.

2.6 The opening in the surround or wall recess for the convection box must be within the limits shown in figure 1(c)

2.7 The minimum allowable distance from the outside edge of the metal front surround of the appliance to a corner wall having combustible materials is 178mm at either side.

2.8 The front face of the wall should be reasonably flat over the area which will be covered by the convection box top and side flanges to ensure a good seal.

2.9 The minimum height from the top surface of the hearth to the underside of any shelf made from wood or other combustible materials is as follows:-

- For a shelf up to 150mm deep
- Minimum height = 750mm.
- For a shelf deeper than 150mm
- Minimum height = 750mm + 12.5mm for every 25mm depth over 150mm.

2.10 Note that soft wall coverings (e.g. embossed vinyl, etc.) are easily affected by heat. They may scorch or become discoloured when close to a heating appliance. Please bear this in mind when installing.

2.11 The appliance must not be installed in any room which contains a bath or shower or where steam is regularly present.

2.12 An extractor fan may only be used in the same room as this appliance, or in any area from which ventilation for the appliance is taken, if it does not affect the safe performance of the appliance. Note the spillage test requirements detailed further on in this manual. If the fan is likely to affect the appliance, the appliance must not be installed unless the fan is permanently disconnected.

2.13 A fan-powered flue system tends to depressurise the room containing the appliance. Normally no additional ventilation should be required. In exceptional circumstances, however the spillage check (See further on in this guide) may indicate a need for further ventilation in order to ensure that there is adequate air replacement. If necessary seek expert advice. In the Republic of Ireland (IE), permanent ventilation must comply with the rules currently in force.

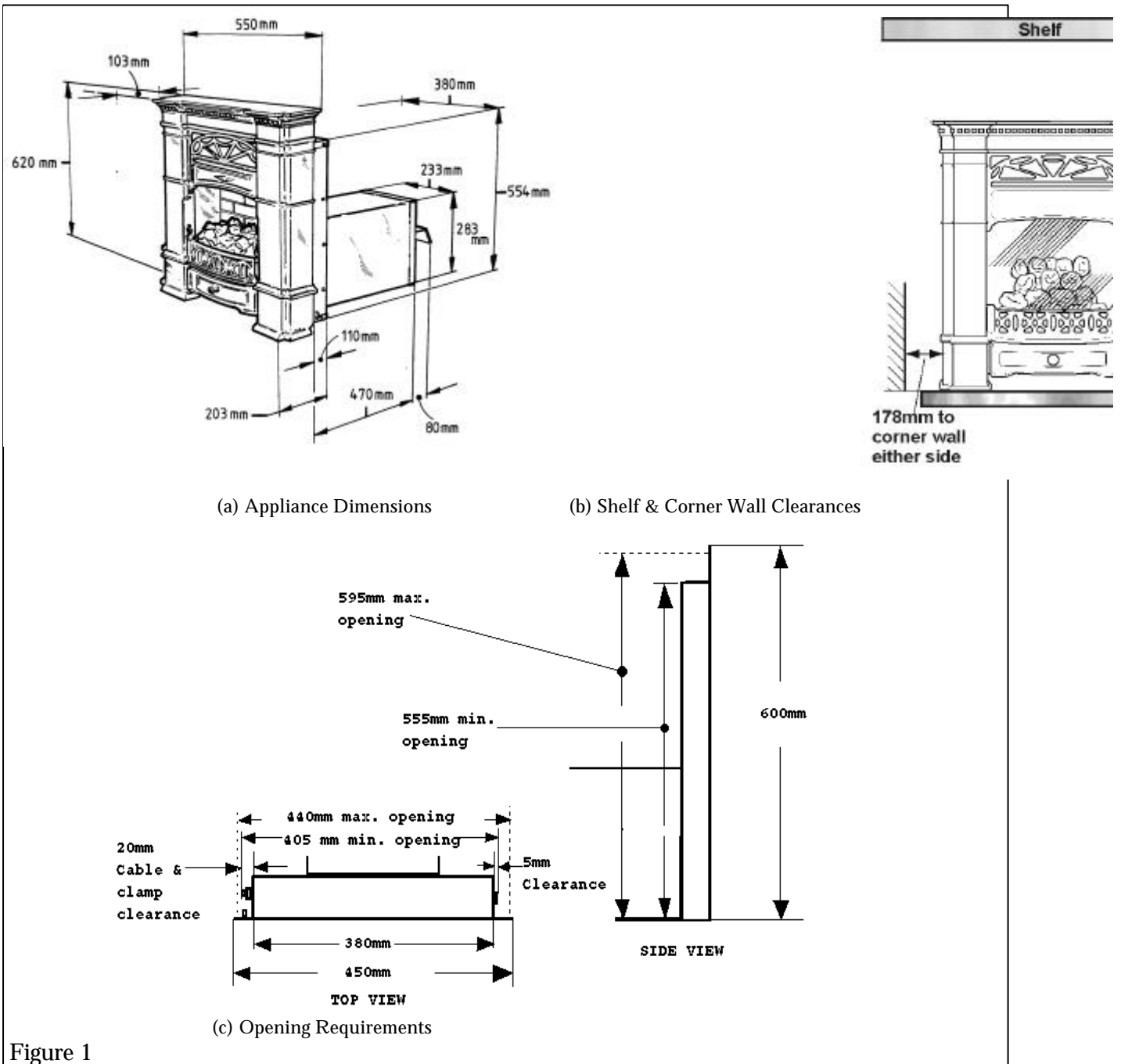

Figure 1

2.14 The flue terminal should be located so that the wind can blow freely across it at all times and where any blockage due to leaves, snow, etc. is unlikely. The minimum allowable distances from the terminal are shown in the following table and figure 2. *Note: The distances are from the edge of the vertical exit slots in the terminal not from the edges of the rectangular box (See*

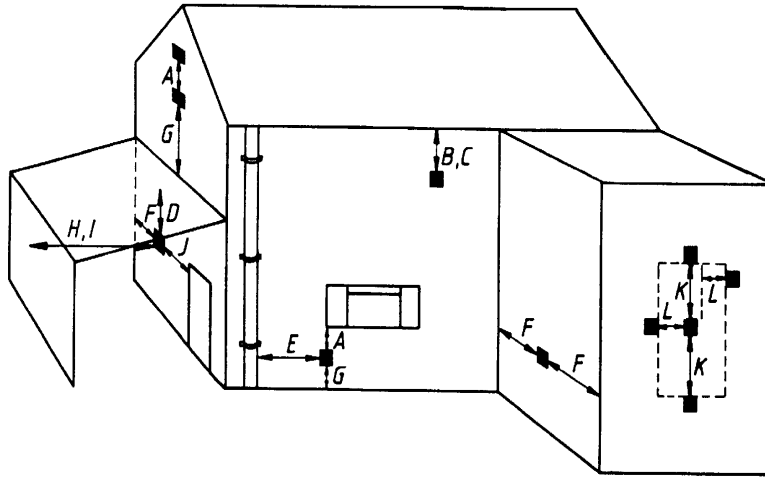
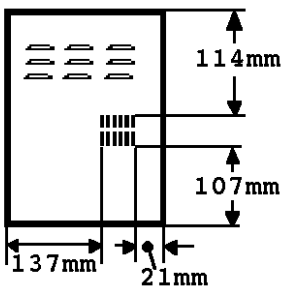

Figure 2 Terminal positions & minimum distances

Terminal Position		Minimum Distance
Below an opening, air brick, etc.		300mm
Near water, soil pipes or drain pipes		75mm
Near balconies		200mm
Near eaves		200mm
Near gables or car port roof		200mm
Near vertical drain pipe or soil pipe		75mm
Near internal or external corner		200mm
Near ground, roof or balcony level		300mm
Near surface facing the terminal		600mm
Near terminal facing the terminal		1200mm
Near opening in a car port (e.g. door, garage) into dwelling		1200mm
Near a terminal on the same wall		1500mm
L	Horizontally from a terminal on the same wall	300mm
M	Projection outwards from wall	15mm



Minimum distances for terminal positions shown in the table are from slot openings

Figure 2a

2.15 This appliance is supplied with a terminal guard. In England and Wales, the Building Regulations require that the terminal guard is fitted if the flue terminal can come in contact with people near the building or be subject to damage. Even if the regulations do not demand it, we recommend that the guard is fitted to prevent damage or blockage of the flue system by leaves etc.

2.16 A concealed gas supply connection can be made through the right side panel or near the right corner of the rear panel. Visible front connection can be from the left or right side.

2.17 Electrical connection is from the left side.

PART3: UNPACKING

The pack contains:

- 1 Burner & convection box unit fitted with front surround and fanned flue unit
- 1 Nut & olive for 8mm inlet pipe
- 1 Ceramic back wall
- 1 Front base coal
- 1 Rear base coal
- 1 Pack of 9 loose coals
- 1 Template
- 1 Smoke match tube
- 1 Terminal weather shield
- 1 Terminal guard
- 2 Screws & washers for terminal guard
- 6 Wall plugs
- 6 Woodscrews
- 1 Literature pack

Carefully remove the contents. Take special care in handling the ceramic walls and the coals.

Check that all the listed parts are present and in good condition.

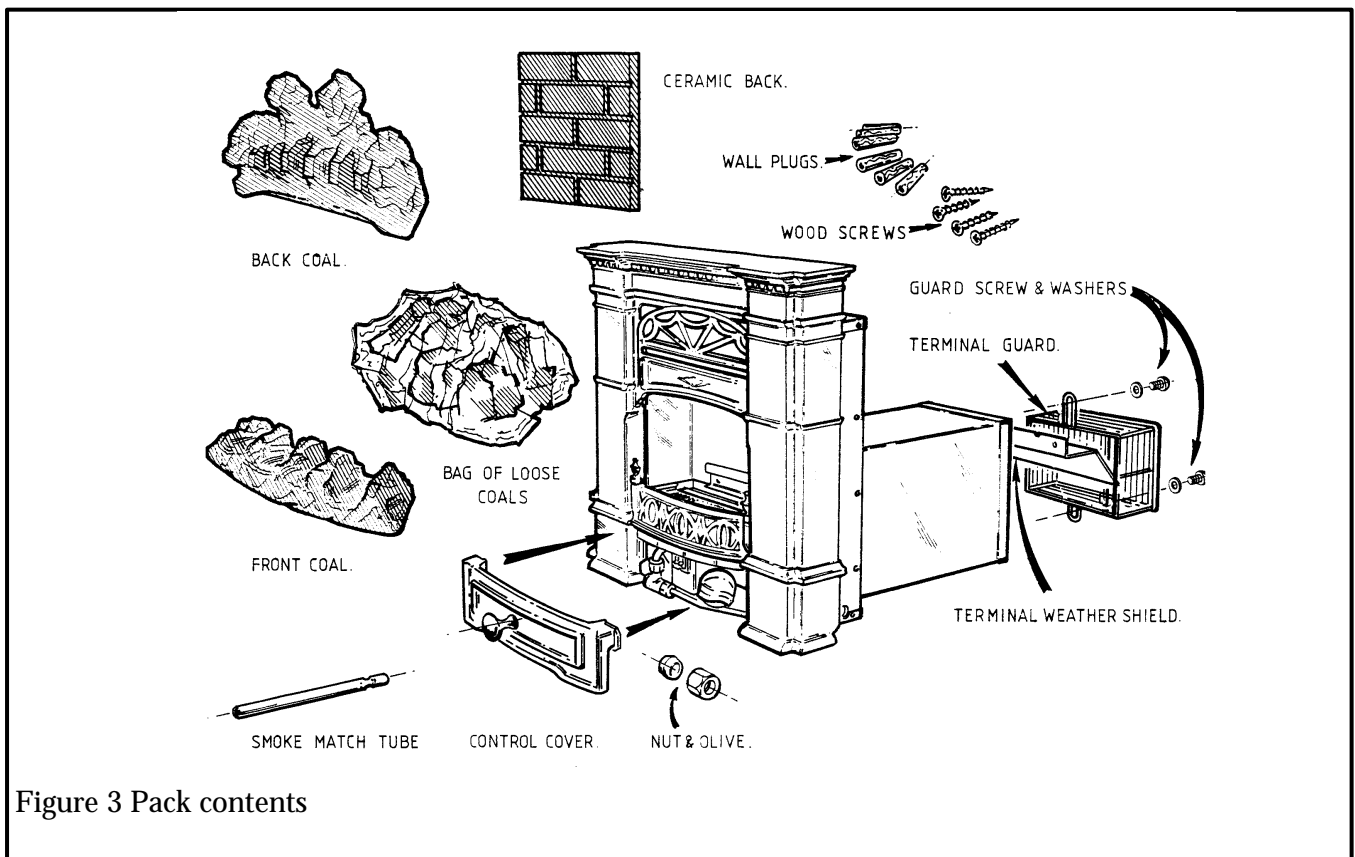
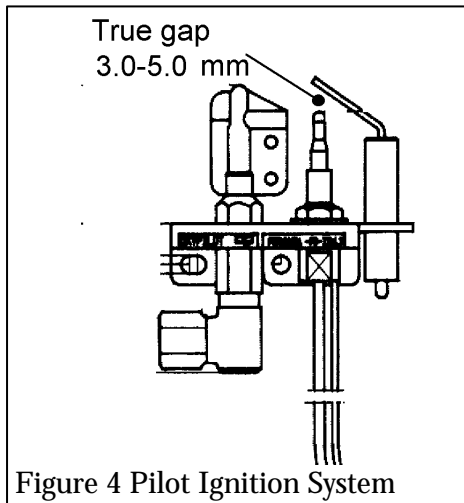

Figure 3 Pack contents

PART 4: PREPARING APPLIANCE FOR INSTALLATION



4.1 Check ignition spark

Before attempting to install, it is worth checking that the piezo electric spark ignition system operates satisfactorily.

To initiate the spark, depress the control knob and while keeping it depressed, turn anticlockwise through approximately 60° to the "PILOT/IGN" position. A spark should track from the electrode pin to the thermocouple tip. If there is no spark or incorrect tracking, check the spark gap between the electrode wire and thermocouple tip (see figure 4).

If the spark gap is correct, check the ignition wiring.

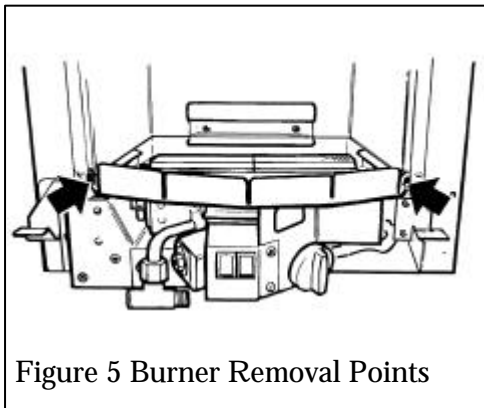

4.2 In the majority of cases (Fixing the appliance to the floor, removal of mains cable for ease of connection to isolating switch), the burner unit will need to be detached. Detach the burner unit from the convection box by removing two screws (see figure 5).

PART 5: WALL PREPARATION

5.1 GENERAL

5.1.1 Make sure that the installation will comply with all the relevant requirements in part 2 of this manual.

5.1.2 Attempt to keep the hole sizes as close to the minimum dimensions as possible in order to minimise the sealing required

5.1.3 Make sure that the damp course or any electrical wiring, piping etc in the wall is not affected when cutting the installation hole.

5.1.4 Any gas supply pipe installed in the wall, floor or cavity of a cavity wall must be continuous and enclosed in a factory fitted gas tight sleeve (Ref: Gas safety (Installation & Use) Regulations 1994 as amended & Certificate of exemption no.1 1996)

5.2 BRICK, STONE ETC. BUILDING. CONVECTION BOX IN

F
R
O
N
T

O
F

W
A
L
L

(
F
i
g
u
r
e
6
)

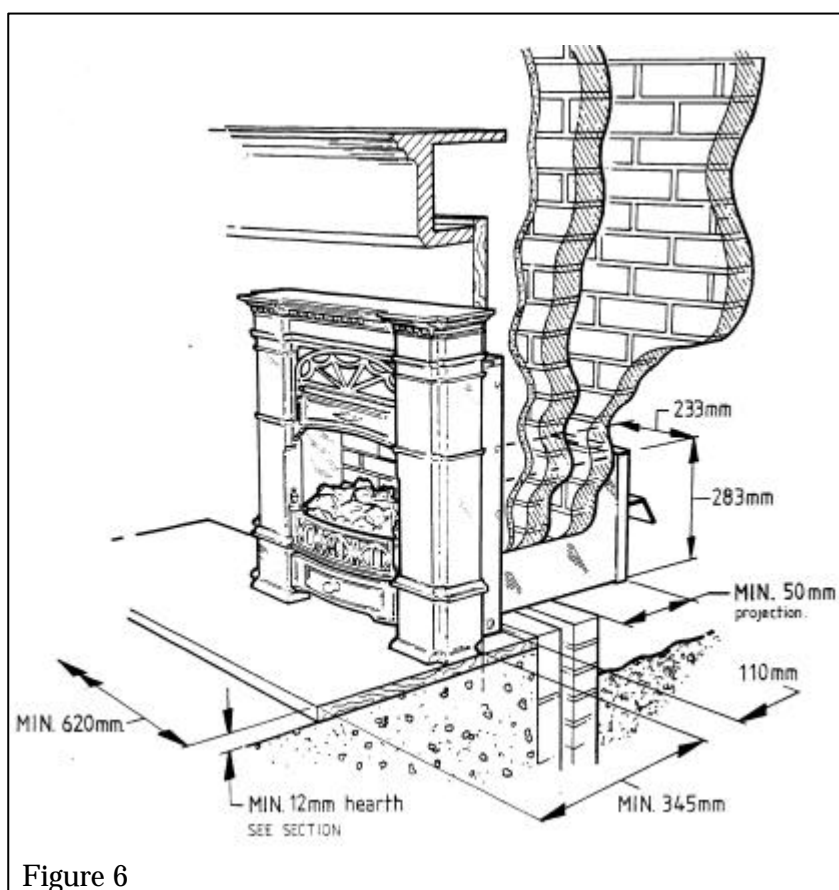

5.2.1 Figure 6

This installation is for use with a fire surround or false chimney breast having a minimum depth of 114mm (4½ in.). The maximum possible surround depth will depend on the wall thickness bearing in mind that the terminal must project at least 15mm beyond the external face of the wall to allow the end cover to be removed and refitted during servicing.

5.2.2 Combustible material within a false chimney breast must be at least 75mm from the convection box.

5.2.3 The non-combustible hearth must project at least 345mm in front of the convection box front flanges and be at least 620mm wide (Figure 6).

5.2.4 Make a hole through the wall to cater for the flue box (Figure 6).

The bottom of the hole must be at the same level as the top surface of the hearth.

5.2.5 In almost every case, it will not be necessary to support the hole with a lintel. If, however the wall is of poor construction seek expert building advice before commencing to cut the hole.

5.2.6 The cavity should be sealed where the flue box hole has been cut. We recommend filling fully across the cavity with Rockwool or equivalent to at least 100mm above and each side of the opening. Fill at the bottom of the opening to the level of the hearth/fireplace floor. See figure 7.

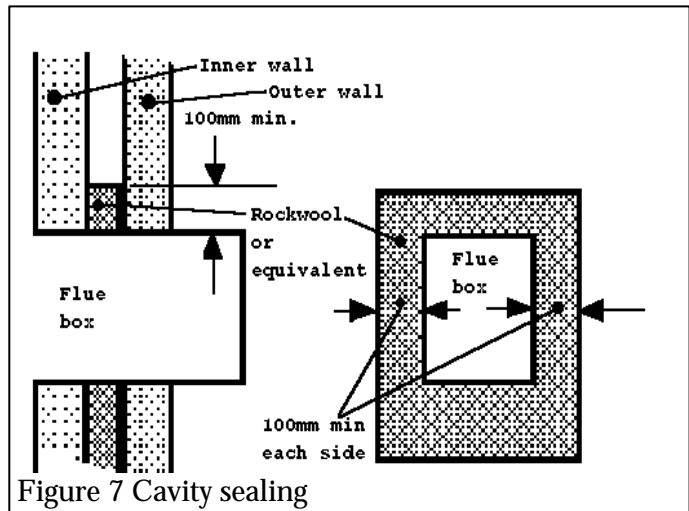

Figure 7 Cavity sealing

5.3 BRICK, STONE ETC. BUILDING. CONVECTION BOX RECESSED INTO WALL (Figure 8)

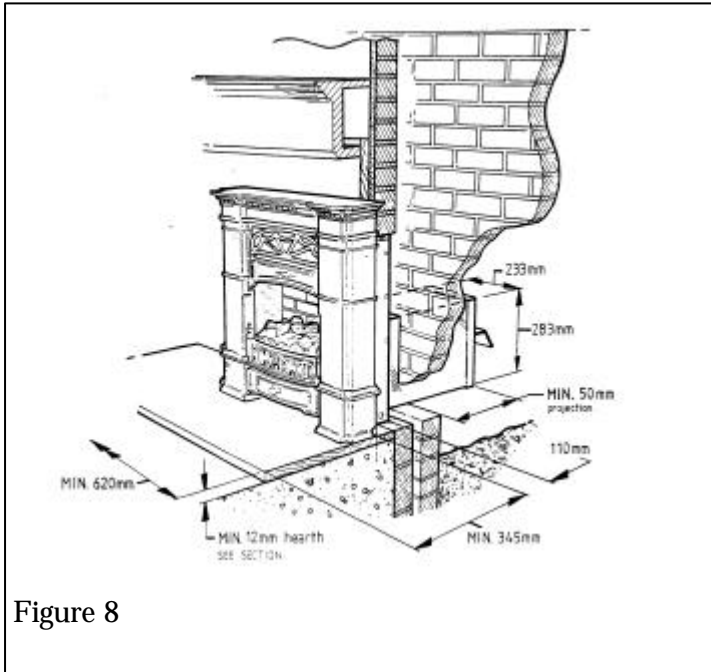

Figure 8

5.3.1 This installation has the convection box recessed into the wall of the building. The front flanges of the convection box and the appliance metal decorative surround will abut the front surface of the wall.

5.3.2. The non-combustible hearth must project at least 345mm in front of the convection box front flanges and be at least 620mm wide (Figure 8).

5.3.3 The recess in the inner wall for the convection box should be to the size shown in figure 1. The bottom of this recess should be at the same level as the top surface of the hearth.

5.3.4 A lintel may be required above the recess for the convection box. If in doubt, seek expert building advice before commencing to cut the recess.

Whenever a lintel is required to support the recess in the inner leaf of a brick/blockwork

building, follow the method outlined below. See figures 8a & 8b.

1. The lintel should be either steel (Catnic) or reinforced precast concrete. It should be 750mm long x 75mm deep x inner leaf thickness.
2. The opening should be, as near as possible, centrally below a joint in the inner leaf block.
3. Cut out the opening for the lintel.

Where cutting through masonry, drill pilot holes and then cut out the slot using a mechanical cutter. This will minimise damage to the surrounding structure.

4. Insert the lintel. Bed the lintel on mortar. Don't dry bed. Slate pin to ensure the lintel and structure above is secure and safe

5. Make the opening below the lintel by removing the masonry and clearing debris. If the cavity has loose fill (e.g. granular) insulation material, pack the edges of the opening with Rockwool as you proceed to hold back the insulating material.

5.3.5 Note that more clearance between the recess and the convection box is required at the left side than at the right side (Figure 1c). Bear this in mind when centring the flue box hole.

5.3.6 The rectangular hole through the wall to cater for the flue box should be to the size shown in Figure 8. The bottom of the hole should be at the same level as the top surface of the hearth. In almost every case, it will not be necessary to support this hole with a lintel. If, however the wall is of poor construction seek expert building advice before commencing to

cut the hole.

5.3.7 The wall cavity must not be bridged other than by the flue box. The convection box must not project into the cavity between the inner and outer walls by more than 10mm.

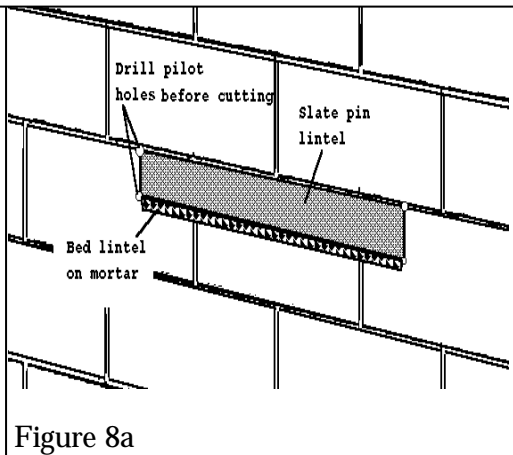

Figure 8a

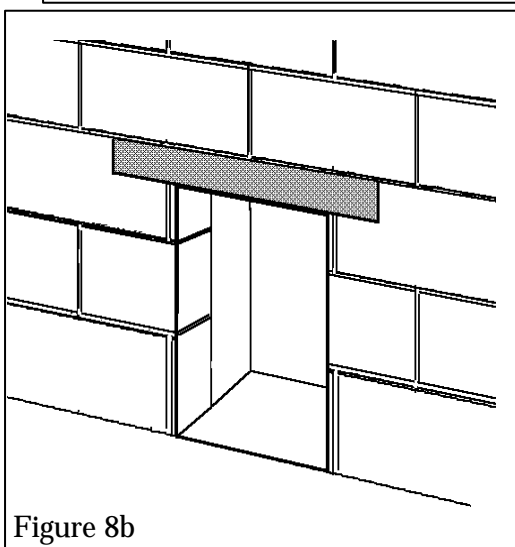

Figure 8b

5.3.8 The cavity should be sealed where the opening has been cut. We recommend filling fully across the cavity with Rockwool or equivalent to at least 100mm above and each side of the recess opening. Fill at the bottom of the opening to the level of the hearth/fireplace floor. It may be simplest to back fill the cavity with the insulation material and then cut through the insulation to the size of the flue box hole.

An alternative to rockwool **above** the opening is to seal across the top of the cavity with superlux board or equivalent. The board should slope downwards to the back so that any moisture will be channelled to the outside.

See figure 8c.

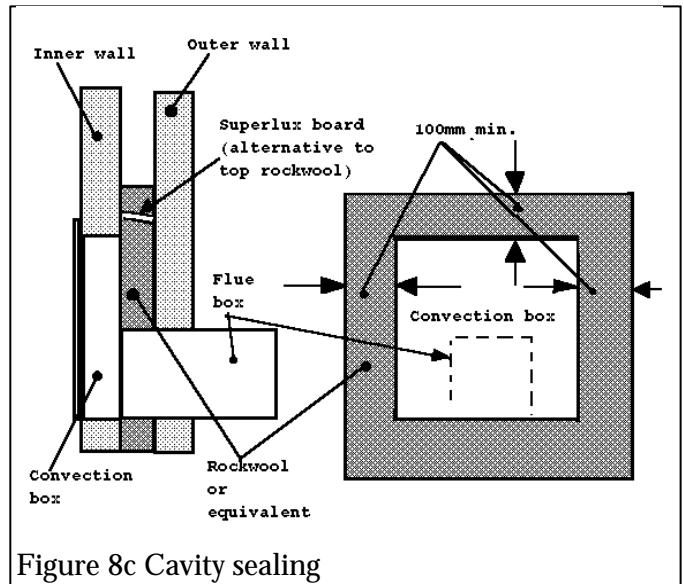

Figure 8c Cavity sealing

5.4 TIMBER FRAME BUILDING. CONVECTION BOX IN FRONT OF WALL (Figures 9 & 9a)

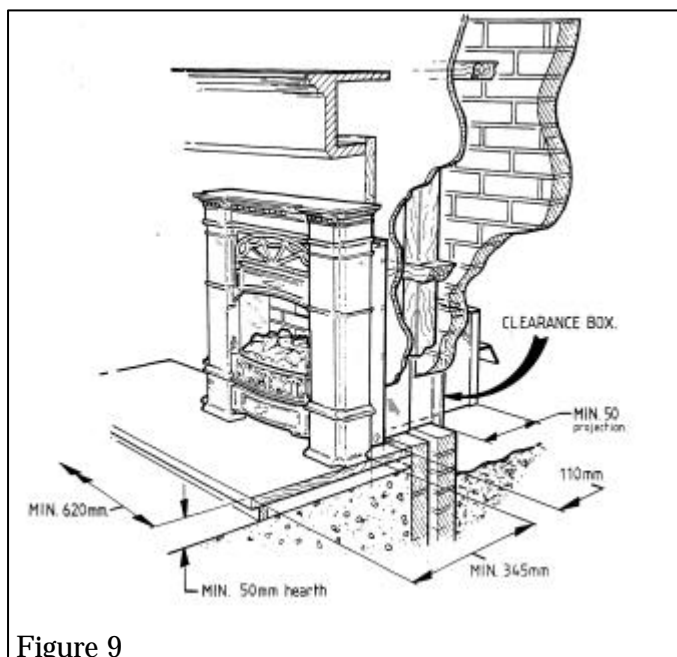

Figure 9

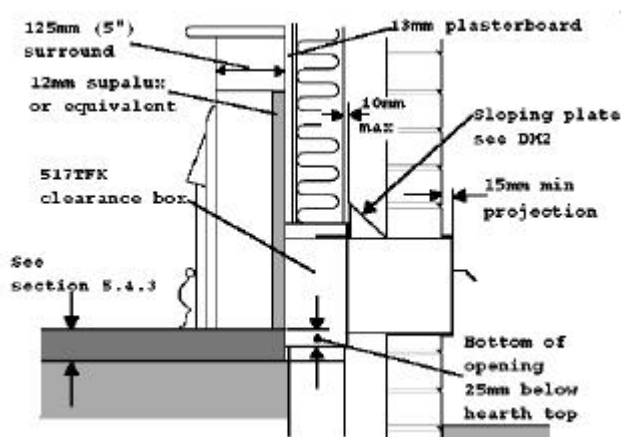

Figure 9a

5.4.1 This installation is for use in timber framed buildings in conjunction with a fire surround having a minimum depth of 127mm (5in.). The maximum possible surround depth will depend on the wall thickness bearing in mind that the terminal must project at least 15mm beyond the external face of the wall to allow the end cover to be removed and refitted during servicing.

5.4.2 This installation requires the optional clearance box part no. 517TFK. The kit is suitable for combustible inner walls up to a maximum total thickness of 180mm.

5.4.3. The non-combustible hearth must project at least 345mm in front of the convection box front flanges and be at least 620mm wide (Figure 9). For this type of installation the hearth must be at least 50mm thick over its total area. Kit 517TFK is

designed for use with a hearth which is at least 50mm thick over its total area. For a hearth less than 50mm thick but at least 25mm thick, the bottom flange of the kit can be cut off. A hearth less than 25mm thick over its total area can not be used.

5.4.4 Installation must be in accordance with the current edition of The Institute of Gas Engineers publication IGE/UP/7 "Gas installations in timber frame buildings".

5.4.5 The back surface of the convection box and front flanges of the clearance kit must be separated from the timber frame by 25mm of non-combustible material. This can consist of the usual 13mm plasterboard wall lining plus 12mm of "Supalux" or similar non-combustible material.

5.4.6 The clearance box requires a rectangular opening 285mm wide x 335mm high through the combustible inner leaf. The bottom of this opening must be 25mm below the top surface of the hearth

5.4.7 The opening should be between studs.

5.4.8 If creating the opening involves cutting through the sole plate and/or bottom plate frame of the building, secure the cut ends to the substrate by pinning or equivalent.

5.4.9 Make sure that the vapour barrier is cut carefully and made good to maintain its integrity .

5.4.10 A sloping plate should be fitted above the clearance kit in accordance with The Institute of Gas Engineers publication IGE/UP/7 "Gas installations in timber frame buildings". Section 8.2.1.7. See figures 9 & 9a.

5.4.11 Installing the clearance kit in the cut opening (See figure 9a).

1) Measure the distance from the face of the inside wall (including any "Supalux" or other insulation mentioned in section 5.4.5) to the cavity in the wall.

- 2) Cut the clearance kit to size so that it will not project into the cavity by more than 10mm.
- 3) Insert the box into the opening
- 4) Mark the securing hole positions on the wall.
- 5) Remove the box. Drill the wall and insert plugs if necessary.
- 6) Refit the box. Secure with the screws provided with the kit.
- 7) Mark the securing hole positions on the wall
- 8) Seal any gaps between the inside wall surface and the box flanges with a bead of a suitable sealant.
- 9) Install the surround.(See Part 9 of this guide)

PART 7: APPLIANCE INSTALLATION

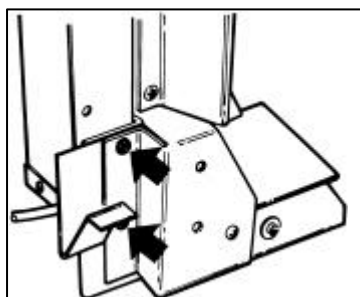

Figure 10 Electrical control unit fixings

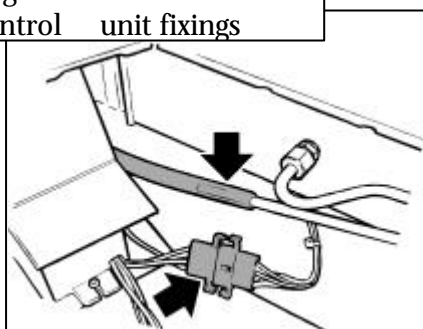

Figure 11 Fan loom & vacuum pipe connections

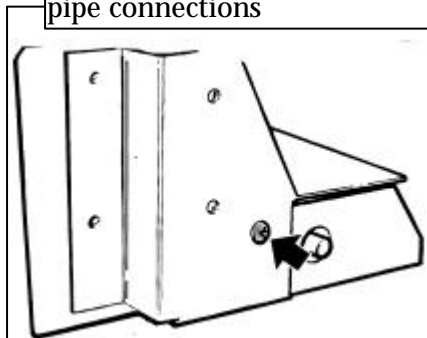

Figure 12 Control cover fixing

6.1 Install a power supply at a switched fuse having a minimum separation of 3mm at all poles. The spur should be readily accessible to the user, easily identifiable and preferably sited adjacent to the appliance. It should only connect this appliance.

6.2 To simplify installation of the cable supplied, it may be most convenient to disconnect it from the appliance as described below, install it to the wall and then reconnect to the appliance:

To disconnect the cable:

- 1) Detach the burner (See section 4.3).
- 2) Detach the control unit from the convection box left side flange by removing two screws (see figure 10). Carefully pull the unit slightly forward.
- 3) Detach the fan wiring loom connection (See figure 11).
- 4) Detach the plastic vacuum tube from the metal vacuum pipe (see figure 11).
- 5) Detach the control unit cover by removing one screw (See figure 12).
- 6) Remove the cable by releasing the cable clamp and detaching the three leads.

6.3 When installing the cable, leave a minimum of 200mm of the cable slack at the cable clamp end to allow installation of the appliance after reconnection to the control box and to allow future removal of the control box for servicing.

6.4 If the spur is at the right side of the appliance, run the cable under the hearth. ***The cable must not run directly under or behind the appliance.***

7.1 If the gas supply pipe is to enter through the concealed rear or side opening, pierce the relevant grommet (See figure 13). If the supply pipe is sleeved, trim the sleeve back where it enters the appliance and seal the sleeve to the pipe. If using the concealed side opening, we suggest that the supply pipe is cut so that it enters the side of the appliance by approximately 25mm and, after fitting the unit to the wall, using a compression elbow, connect to a formed pipe running to the appliance elbow.

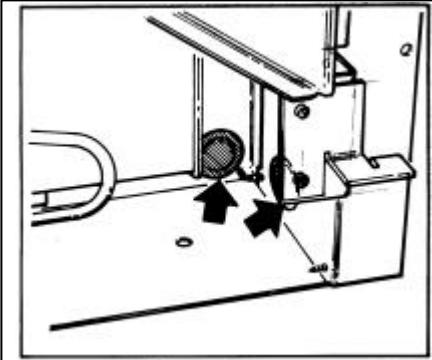

Figure 13 Concealed openings

7.2 An installation template is supplied which includes a diagram for forming the pipe so that it avoids various components below the burner

7.3 If the unit is to be fixed to the floor:

- Place the template in position and mark the floor at the positions of the two fixing holes.
- Drill two holes at the marked positions using a no. 10 drill and plug.

7.4 For fixing the unit to the wall (see figure 14):

- Offer the unit to the prepared hole in the wall. Gently push back until the convection box is squarely against the wall.
- Mark through the four holes in the convection box side flanges.
- Remove the unit.
- Drill four holes at the marked positions using a no. 10 drill and plug.

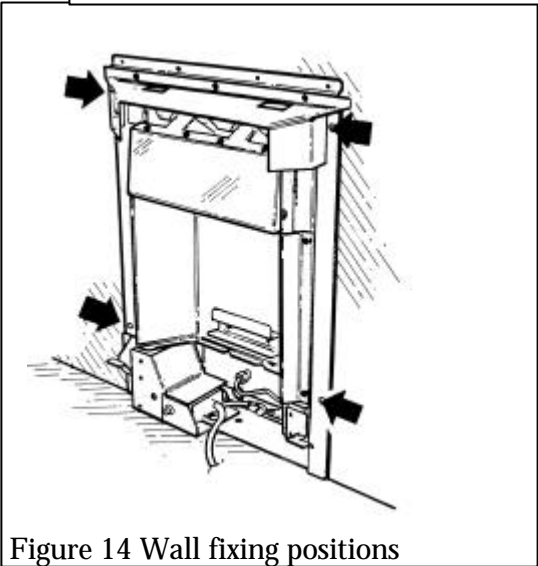

Figure 14 Wall fixing positions

7.5 Place the unit back in position.

- The slack length of cable should be looped in the space at the left side of the convection box .

7.6 If wall fixing , fit woodscrews through the convection box flanges.

7.7 If floor fixing, fit woodscrews through the convection box base. Replace the burner unit.

7.8 If necessary, seal any gaps between the wall and the convection box flanges with a bead of suitable sealant.

7.9 Seal the flue box to the external wall surface.

PART 8 : ELECTRICAL TEST

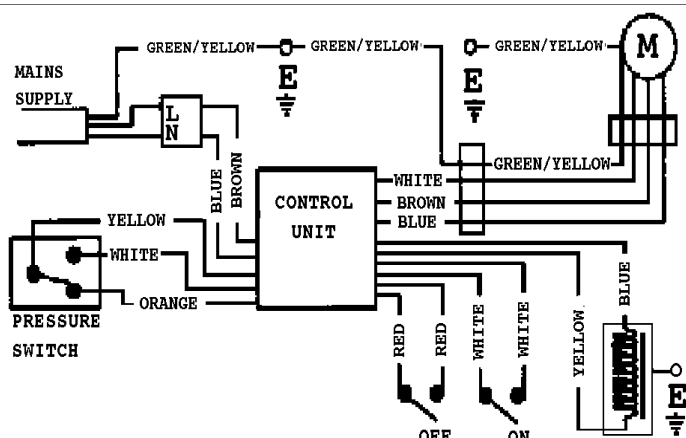

Figure 15 Wiring diagram

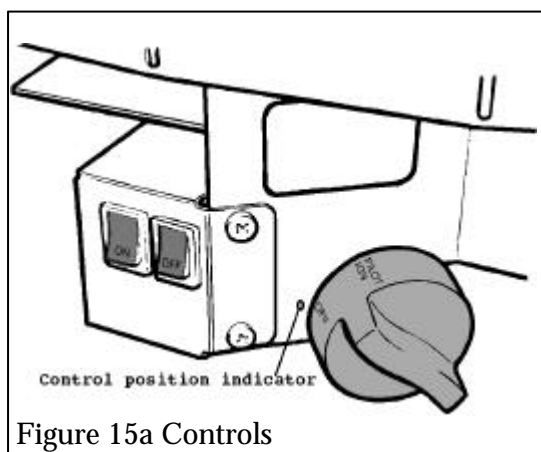

Figure 15a Controls

8.1 Switch on power supply. The red indicator light at the left side of the burner should be on.

8.2 Press and hold in the “on” switch. Within two seconds, the Fan motor should start and the indicator light should go out.

8.3 Release the “on” switch. The fan should continue to run.

8.4 Press the “off” switch. The fan should stop and the indicator light should come on.

- 8.5** The fan has a “boost” speed intended to clear any minor exhaust obstructions. To check its operation:
- i. Switch the fan on (8.1 to 8.3 above).
 - ii. Go outside the building and place a hand over the rectangular exhaust outlet of the terminal. The fan should be heard to increase to “boost” speed within approximately two seconds.
 - iii. Remove the hand. The fan should revert to normal speed after approximately three seconds.

8.6 The unit includes a blocked flue sensor system. To check its operation:

- i. Switch the fan on (8.1 to 8.3 above).
- ii. Block off the rectangular exhaust outlet of the terminal. The system should shut down and the indicator should light within ten seconds.
- iii. After checking remove the flue blockage.

If the above tests are not satisfactory, refer to the servicing section of this manual.

Note: At times of very windy weather or low voltage conditions the fan may switch between boost and normal speeds. A click from the atmospheric pressure sensor may be heard as the fan switches speeds.

PART9:INSTALLING THE CAST IRON FIREFRONT

9.1 Warning! The Lincoln front is cast iron weighing around 20kg (44lbs). To avoid any risk of injury, if you have any doubt of your ability to easily lift this front ask someone to assist you.

Having assistance when installing this front will also reduce the risk of damaging the front or anything nearby. We suggest that parts of the cardboard packaging, or similar, is used to protect the hearth and fireplace surround.

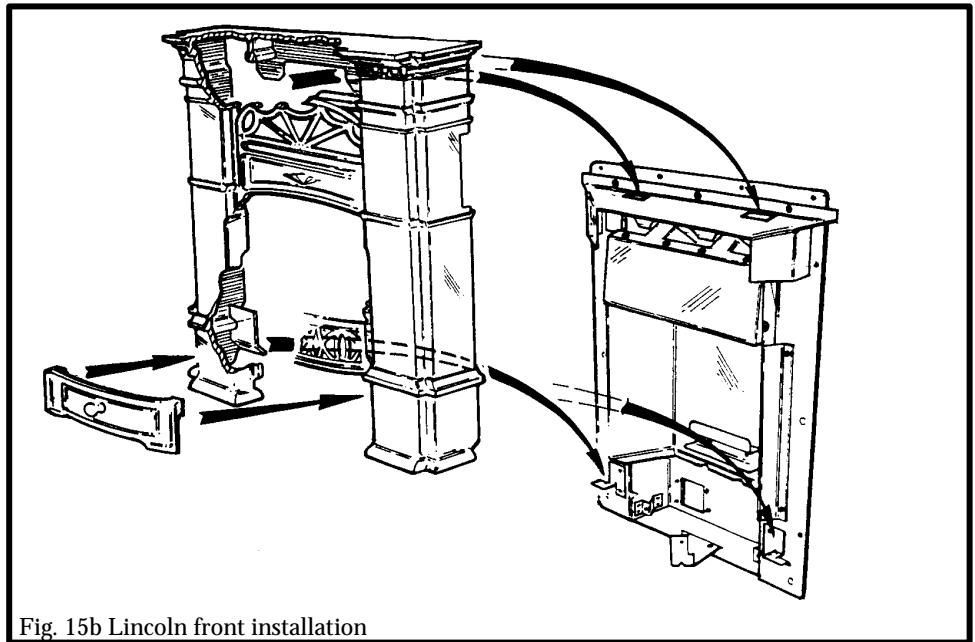

Fig. 15b Lincoln front installation

9.2 The front has a location plate at the rear of the mantle shelf and a lug at the rear of each vertical column. These locate into the convection box. Carefully lift the cast front into position square with the convection box taking care not to damage the slide control mechanism.

Holding the cast front a little above the top surface of the convection box, locate the two lugs into the lower case support brackets and the upper location plate into the two slots in the upper case front support. Gently lower the cast front onto the hearth making sure that it causes no damage to the hearth or fireplace surround. The cast front should sit squarely on the hearth and against the vertical surface of the fireplace. See figure 15b.

Note: If the gas supply is across the hearth, make sure that the supply pipe is located through the purpose provided slot in the front casting – See figure 15c.

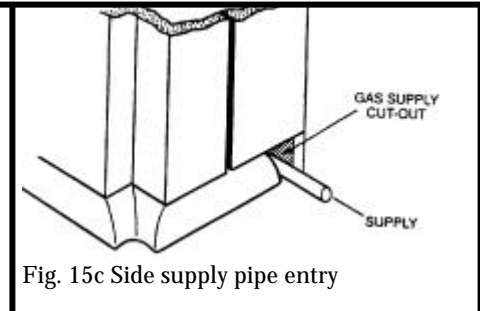

Fig. 15c Side supply pipe entry

PART 10: TERMINAL GUARD & GAS SUPPLY INSTALLATION

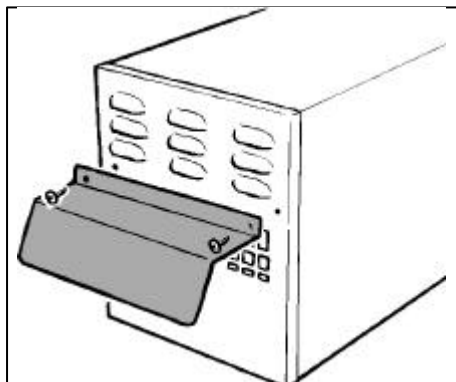

Figure 16 Weather Shield Installation

10.1 Fit the weather shield and guard to the back of the flue unit as detailed below (see figures 16 & 16a).

10.1.1 Remove the two screws near the sides of the terminal end just below the louvres. Remove the screw near the bottom of the terminal end.

10.1.2 Slacken the terminal end plate to remove the lifting strap. Discard the strap. Replace the end plate.

10.1.3 Place the weather shield in position aligning the holes in the shield with those at the sides of the end plate. Secure with the two screws previously removed. see figure 16.

10.1.4 Fit the terminal guard. Secure the guard at the bottom with the screw and washer previously removed. Secure the guard at the top between the two right hand columns of louvres using the screw and washer supplied in the pack. see figure 16a.

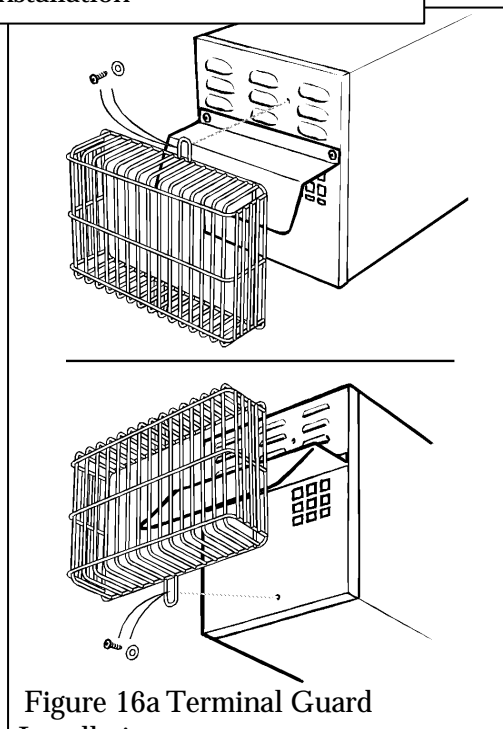

Figure 16a Terminal Guard

10.2 Locate the two lugs at the top of the front surround in the slots in the convection box hood. Swing the bottom of the surround sides back against the convection box and lower the surround so that the lugs are fully seated in the slots in the convection box hood.

10.3 Refit the two screws to secure the surround sides to the convection box brackets.

10.4 Connect the supply line to the appliance. Unless the supply pipe connection is from the left front side, the supply pipe will have to be formed to avoid various components below the burner. An installation template is supplied which contains a diagram for bending this supply pipe.

10.5 Pressure check the installation pipework for gas soundness in accordance with the current edition of BS6891.

Do not use leak detection sprays on this appliance. Sprays may affect the operation of electrical components. Keep all liquid detection fluids clear of electrical components. A long brush may be required to reach some joints.

10.6 Preliminary Burner Checks

Some burner operations can be checked at this stage. Checking now will mean that less disassembly will be required if any problems are found. **A full check should still be made, however, after final installation.**

10.6.1 Switch on electrical power supply. The red indicator light at the left side of the burner should be on.

10.6.2 If closed, open the isolating valve at the inlet elbow.

10.6.3 Press and hold in the “on” switch. Within two seconds, the Fan motor should start and the indicator light should go out.

10.6.4 Release the “on” switch. The fan should continue to run.

10.6.5 Depress the control knob and turn anticlockwise partially towards the “PILOT/IGN” position until some resistance is felt. Keep depressed at

this position to purge air from the system then, while keeping it depressed, turn fully to the “PILOT/IGN” position. A spark should be generated at the pilot while turning. The spark should ignite the pilot.

10.6.6 When pilot ignition has been achieved, keep the control knob depressed for approximately ten seconds to allow the thermocouple probe to warm up and then release it. If the pilot does not remain alight, ensure that the air has been purged, that the pilot orifice is clear and that the thermocouple connections are sound. Replace the pilot unit if necessary (see servicing section of this manual).

10.6.7 When the pilot is alight and stable, partially depress the knob and turn to “LOW”. The pilot should then light the main burner at its low setting. There may be a delay of up to four seconds between the pilot lighting and ignition of the gas at the main burner. This is normal and is due to the time required to fill the main burner compartment with sufficient gas for ignition.

10.6.8 With the burner at “LOW”, partially depress the control knob and gradually turn it anti-clockwise. The burner flames should gradually increase until the knob reaches the “HIGH” position. ***When the above checks have been completed partially depress the control knob and turn to “OFF”.***

10.6.9 Press the “off” switch. The fan should stop and the indicator light should come on.

10.6.10 If the above checks are satisfactory, continue with the installation. If not, check the control and ignition circuitry and components as described in the servicing section of this manual.

10.7 Check Reference Pressure

The appliance is pre-set to give the correct heat input at the inlet pressure shown in part 1 of this manual. No adjustment is necessary. Check the burner pressure by fitting a pressure gauge at the test point. The test point is on the pipe situated below the bottom right corner of the burner unit (See figure 17). Check the pressure with the fan on, the appliance alight and set at maximum output.

After checking, turn off the appliance. Remove the pressure gauge and replace the test point sealing screw. Relight the appliance. Turn to the maximum output position and test around the sealing screw for gas soundness with a suitable leak detection fluid (***Do not use a liquid detection spray See section 10.5***).

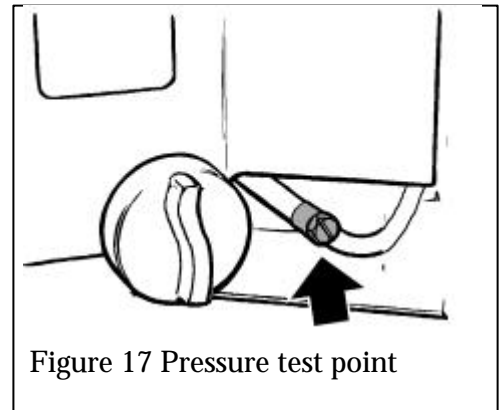

Figure 17 Pressure test point

PART 11: CERAMIC COALS & WALL INSTALLATION

11.1 With its feather edge at the top, place the ceramic rear wall into the channel at the back of the firebox. Push the wall flat against the rear of the fire box. (See figure 18).

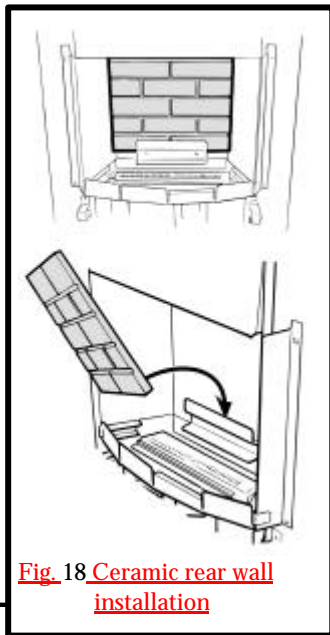

Fig. 18 Ceramic rear wall installation

11.2 Fit the tray trim over the front edge of the burner tray. Make sure that it is pushed down fully. Place the front base coal in the burner compartment so that it rests on the ledges at the sides and front. Pull the coal forward so that it is immediately behind the front rim of the burner compartment. (See figure 19).

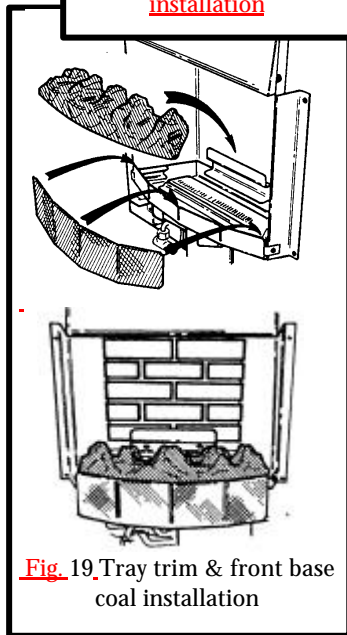

Fig. 19 Tray trim & front base coal installation

11.3 Place the rear base coal in the burner compartment behind the front coal. It should rest on the ledge at the back of the burner compartment and its rear face should touch the rear ceramic wall (See figure 20)

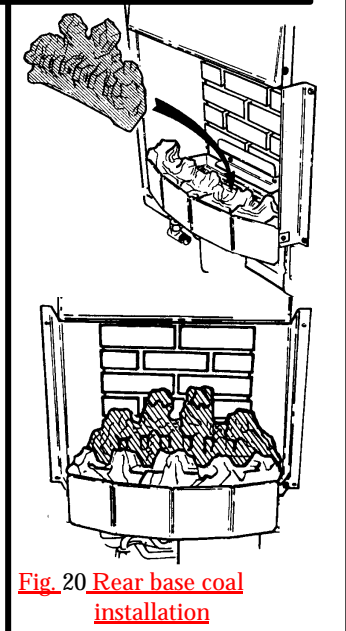

Fig. 20 Rear base coal installation

11.4 Install the 9 loose coals as follows. The smooth surfaces of the coals should be at the bottom and back.

11.4.1 Select the two smallest coals and put them aside until all the other coals are installed.

Place four of the medium size coals in the four valleys of the front coal. Place the left side coal so that the pilot flame will be visible. (See figure 21).

11.4.2 Place the three remaining medium size coals behind and approximately midway between each of the coals in the front row (See figure 22).

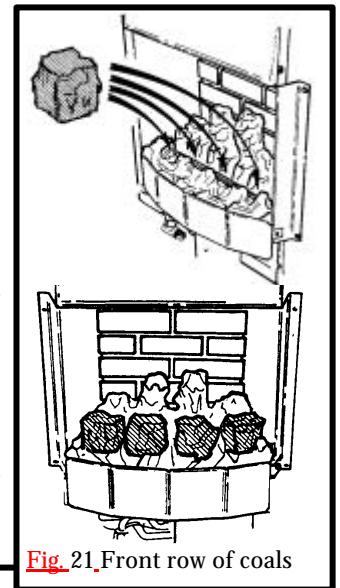

Fig. 21 Front row of coals

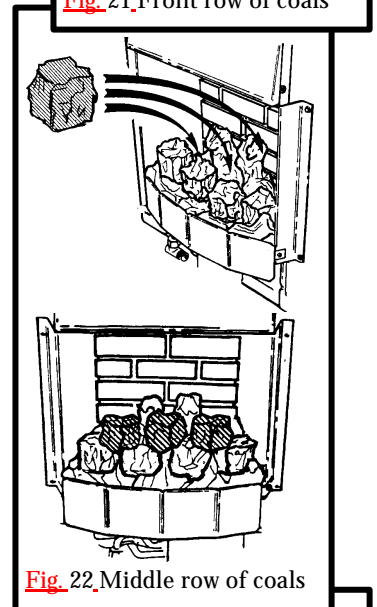

Fig. 22 Middle row of coals

11.4.3 Place the two remaining small coals alongside the main coals (See figure 23)

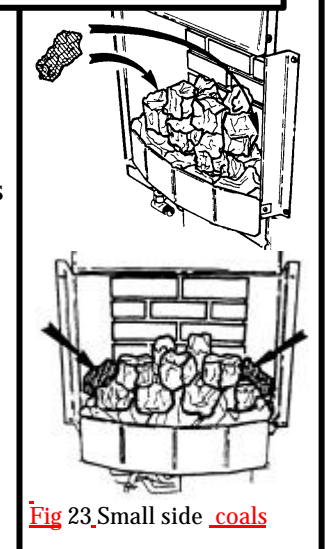

Fig. 23 Small side coals

PART 12 : FULL OPERATING CHECKS

12.1 Recheck Control Settings

Now that all the ceramic fuel effects are in position, the control operation must be fully rechecked.

12.1.1 Make sure that the isolating valve at the inlet elbow is open and that the electrical power supply is on (the indicator light should glow).

12.1.2 Press and hold in the “on” switch. Within two seconds, the Fan motor should start and the indicator light should go out.

12.1.3 Release the “on” switch. The fan should continue to run.

12.1.4 Depress the control knob and turn anticlockwise partially towards the “PILOT/IGN” position until some resistance is felt. Keep depressed at this position to purge air from the system then, while keeping it depressed, turn fully to the “PILOT/IGN” position. A spark should be generated at the pilot while turning. The spark should ignite the pilot. Check that the pilot flame is visible – see section 10.4.1

12.1.5 When pilot ignition has been achieved, keep the control knob depressed for approximately ten seconds to allow the thermocouple probe to warm up and then release it. If the pilot does not remain alight, ensure that the pilot orifice is clear.

12.1.6 When the pilot is alight and stable, partially depress the knob and turn to “LOW”. The pilot should then light the main burner at its low setting. There may be a delay of up to four seconds between the pilot lighting and ignition of the gas at the main burner. This is normal and is due to the time required to fill the main burner compartment with sufficient gas for ignition.

12.1.7 When the burner is operating properly, partially depress the knob and gradually turn it anti-clockwise. The burner flames should gradually increase until the knob reaches the “HIGH” position.

12.1.8 Partially depress the control knob and turn back to “PILOT/IGN”. The main burner flames should be extinguished but the pilot should remain alight.

12.1.9 Partially depress the control knob and turn to “OFF”. The pilot should be extinguished.

12.1.10 Press the “off” switch to turn off the fan (the indicator light should glow).

12.2 Check For Spillage

A spillage check must be made before leaving the installed appliance with the customer. Make this check with the appliance fully installed with the ceramic fuel effects and front surround in position.

12.2.1 Close all doors and windows in the room containing the appliance.

12.2.2 Turn on the fan. Light the appliance. Turn the control to "HIGH".

12.2.3 Leave the appliance on for five minutes.

12.2.4 Place the smoke match tube into the convection box at the right hand side and immediately below the black top cross member. Angle it at approximately 45° to the horizontal (fig. 24).

Insert the tube so that the neck of its flared end touches the inside surface of the edge of the cross member (figure 24).

Keeping the neck of flared end in contact with the edge of the cross member, slide the tube to the left until you feel it enter the notch in the edge of the cross member. Make sure that the tube is pointed upwards at 45° to the horizontal.

The installation is satisfactory if the smoke is drawn into the appliance. If the smoke is not drawn into the appliance the powered fan is not operating correctly. **Do not allow the appliance to be used until the fault is corrected.**

12.2.5 If the above test is satisfactory, open all internal connecting doors, hatches, etc. in the room. Switch on any extractor fan or other air circulating system installed in the same room as the appliance or in a connecting room. Keep all doors and windows that open to the outside of the building closed. Recheck for spillage as above.

If the smoke is drawn into the appliance, continue with the installation. If the test is not satisfactory, **Disconnect the appliance and advise the customer of the cause of failure.**

12.2.6 If any other non-sealed gas appliances are installed in the room or connecting rooms, check that to ensure that there is no spillage from these appliances when Model BR517 is operating with its fan on. Check these other appliances by the procedure supplied by the manufacturer.

12.3 Flame Supervision & Spillage Monitoring System

This pilot unit incorporates a system which will automatically shut off the gas supply if the pilot flame goes out or if there is insufficient oxygen due to spillage or lack of ventilation.

Check that the system operates properly as follows;

12.3.1 Turn on the fan. Light the appliance and turn the control knob to "HIGH". Leave for one minute.

12.3.2 Turn back to "OFF" to extinguish the pilot. **Note the time when the pilot goes out.** Listen for a snap sound at the gas tap. **Note the time when the sound is heard.** This sound is caused by an electromagnetic valve shutting off the gas supply through the tap. The valve is located in the body of the tap. The valve should operate **within 60 seconds of the pilot going out.** If the valve does not operate within this time limit do not allow the appliance to be used until the fault has been corrected.

This monitoring system must not be adjusted, bypassed or put out of operation.

This monitoring system, or any of its parts, must only be exchanged using Wonderfire authorised parts.

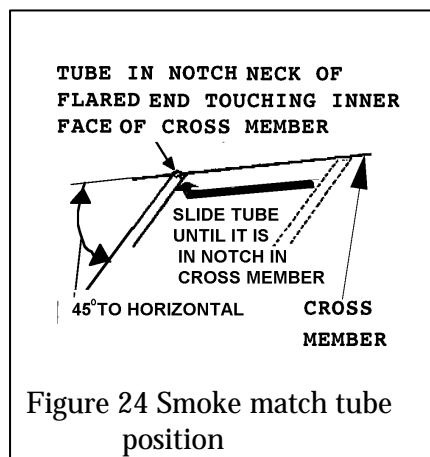

PART 13 : FINAL REVIEW

13.1 Install the cast iron firefront – (See part 9 of this installer guide).

13.2 Visually inspect the appliance. Clean off any marks incurred during installation.

13.3 Hand this guide ,the owner’s guide and the smoke match tube to the customer.

13.4 Advise the customer how to operate the appliance. Point out that lighting instruction details are on a tie at the bottom of the appliance.

13.5 Explain to the customer that the appliance has a flame failure & spillage monitoring system and that the gas supply to the fire will be shut off unless the fan is in operation. Point out the explanation of this system shown in the users guide. Mention that in windy weather or when the mains voltage is low, a slight click may be heard due to the fan control system switching between its normal and boost speeds.

Advise that if the fire goes out for any reason, wait at least three minutes before relighting.

Stress that if the monitoring system repeatedly shuts off the fire, the appliance should be switched off and a specialist should be consulted.

13.6 Advise the customer that they should read their Owner’s guide before operating the fire and always follow the advice in the section headed “Cleaning your fire”.

13.7 *Stress that no extra coals must be added over and above those supplied with the appliance and that any replacements must only be the authorised spares. Warn that ignoring this advice could cause incomplete clearance of the products of combustion with consequent health hazards.*

13.8 Recommend that the appliance should be serviced and the flue unit inspected by a competent person at least annually.

PART14 :SERVICING & PARTS REPLACEMENT

- **Always turn off the gas and isolate the electric supply before commencing any servicing and make sure that the appliance is cold. (The inlet elbow for this appliance incorporates an isolating valve).**
- **This product uses fuel effect pieces, burner compartment walls and gaskets containing Refractory Ceramic Fibres (RCF), which are man-made vitreous silicate fibres. Excessive exposure to these materials may cause temporary irritation to eyes, skin and respiratory tract. Consequently, it makes sense to take care when handling these articles to ensure that the release of dust is kept to a minimum. To ensure that the release of fibres from these RCF articles is kept to a minimum, during installation and servicing we recommend that you use a HEPA filtered vacuum to remove any dust and soot accumulated in and around the fire before and after working on the fire. When replacing these articles we recommend that the replaced items are not broken up, but are sealed within a heavy duty polythene bag, clearly labelled as RCF waste. This is not classified as “hazardous waste” and may be disposed of at a tipping site licensed for the disposal of industrial waste. Protective clothing is not required when handling these articles, but we recommend you follow the normal hygiene rules of not smoking, eating or drinking in the work area and always wash your hands before eating or drinking.**
- Check that the appliance is clean and that soot or debris is not blocking the gaps between the coals causing an imperfect flame.
- Check that soot or debris is not impairing the electrode spark or pilot burner.
- Check that soot or debris is not blocking any of the slots in the main burner.
- Remove any lint from the components
- After servicing, make sure that the ceramic walls and coals are replaced correctly as described in the installation instructions.
- **Always test for gas soundness and spillage after servicing the appliance and check operation of all controls. (Do not use leak detection sprays on this appliance. Sprays may affect the operation of electrical components. Keep all liquid detection fluids clear of electrical components.)**

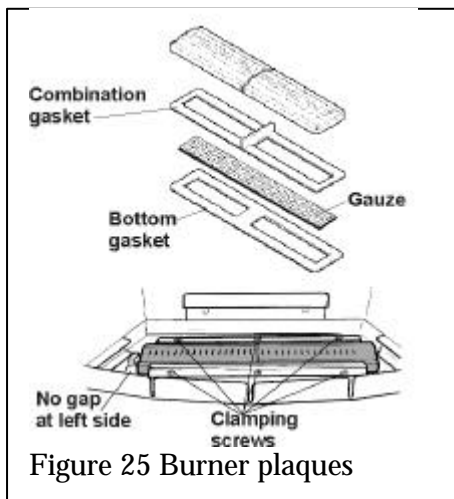

14.1 To Replace Burner Plaques (See Figure 25)

14.1.1 Remove the 9 loose coals, front base coal, rear base coal and ceramic back wall.

The plaques can then be removed as follows without detaching the front surround or front casting.

14.1.2 Remove the plaque clamping strips by detaching 6 screws.

14.1.3 Remove the plaques and the combination gasket between and under the plaques. If necessary remove the gauze and the gasket beneath it.

14.1.4 If necessary fit a new gasket below the gauze. Clean and replace the gauze. Fit a new combination gasket below the plaques. Push the gasket ends inwards to form a dividing gasket between the plaques.

14.1.5 Place the new left hand plaque in position. The left side of the plaque must touch the inside edge of the retaining flange at the left side of the burner well.

14.1.6 Place the new right hand plaque in position. Make sure that the centre section of the combination plaque is between the two plaques. If there is any play between the plaques and the end retaining flanges, push the plaques firmly to the left squeezing the centre section of the combination gasket between the two

plaques. Any gap should be between the right side of the plaque and the right side retaining flange.

14.1.7 Fit the front and rear plaque clamping strips. Make sure that the plaques are as far to the left as possible. ***It is important that the left side plaque is accurately positioned so that it has the correct relationship to the pilot.*** Fully tighten the clamping strips.

14.1.8 Refit the ceramic fuel effects and wall as described in part 11 of this manual.

14.2 To Remove The Front Surround

Warning! The Lincoln front is cast iron weighing around 20kg (44lbs). To avoid any risk of injury, if you have any doubt of your ability to easily lift this front ask someone to assist you.

14.2.1 Remove the bottom front cover.

14.2.2 Raise the Cast front surround so that the lugs in the lower case support brackets and upper location plate are released from their locations in the fire unit – See figure 26. Lift the cast front clear and place safely.

14.2.3 Refit as follows:-

14.2.4 Holding the cast front a little above the top surface of the convection box, locate the two lugs into the lower case support brackets and the upper location plate into the two slots in the upper case front support. Gently lower the cast front onto the hearth making sure that it causes no damage to the hearth or fireplace surround. The cast front should sit squarely on the hearth and against the vertical surface of the fireplace. See figure 26.

14.2.5 If the gas supply is across the hearth, make sure that the supply pipe is located through the purpose provided slot in the front casting.

14.2.6 Replace the bottom front cover.

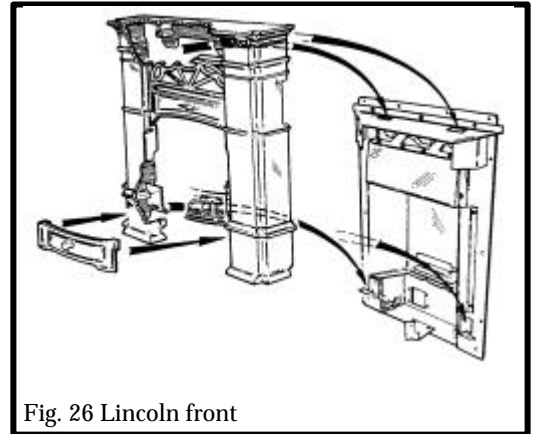

Fig. 26 Lincoln front

14.3 To Remove The Pilot Unit

14.3.1 Remove the 9 loose coals, front base coal, rear base coal and ceramic back wall.

14.3.2 Remove the front surround unit - See section 14.2.

14.3.3 Support the inlet isolating elbow to avoid straining the pipework and disconnect the appliance from the elbow.

14.3.4 Detach the burner unit from the convection box by removing 2 screws (see figure 27). Carefully lift the burner unit forward making sure that the unit does not snag on any leads. Rest the burner on its front face to allow access to the pilot and gas tap.

14.3.5 Disconnect the electrode lead from tab underneath the electrode.

14.3.6 Undo the thermocouple nut at the gas tap.

14.3.7 Disconnect the pilot pipe from the pilot unit elbow.

14.3.8 Remove the first screw securing the dust cage to the pilot unit & burner (see figure. 28). Carefully remove the dust cage and place aside.

14.3.9 Remove the second screw securing the pilot unit to the burner. Remove the pilot unit and place it aside.

14.3.10 Refit in the reverse order. Make sure that no leads are trapped.

Note 1 The pilot unit must be replaced as a whole assembly. Its individual components are not separately replaceable.

2. Once removed, ensure that the dust cage is cleaned before refitting. Make sure that it locates squarely onto the pilot unit without any gaps between the cage edges and the pilot unit.

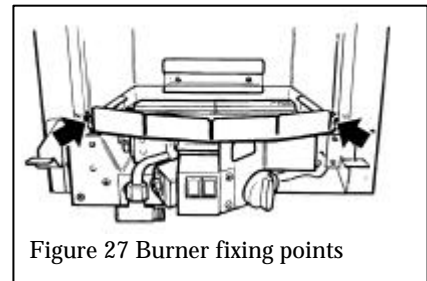

Figure 27 Burner fixing points

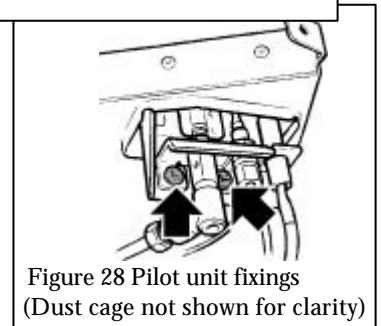

Figure 28 Pilot unit fixings
(Dust cage not shown for clarity)

14.4 To Completely Remove The Burner Unit

14.4.1 Remove the ceramics and front surround, disconnect the appliance and detach the burner unit from the convection box as sections 14.3.1 to 14.3.4

14.4.2 Detach the burner wiring loom connection at the right side of the burner (see figure 29).

14.4.3 Refit in the reverse order. Make sure no leads are trapped.

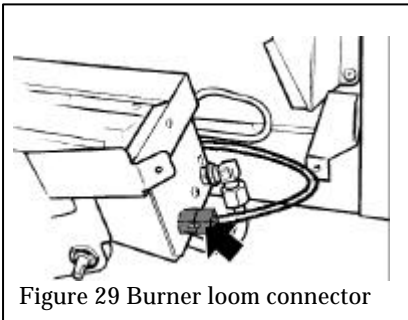

Figure 29 Burner loom connector

14.5 To Remove The Gas Tap/F.S.D & Solenoid Assembly.

14.5.1 Remove the burner unit - See section 14.4.

14.5.2 Disconnect the electrode lead from tab underneath the electrode.

14.5.3 Undo the thermocouple nut at the gas tap.

14.5.4 Disconnect the inlet pipe at the solenoid junction.

14.5.5 Disconnect the main burner pipe at the tap end.

14.5.6 To gain access to the pilot pipe connection, detach the fan switch bracket from the burner control bracket by removing two screws (see figure 30).

14.5.7 Disconnect the pilot pipe at the tap end.

14.5.8 Pull off the control knob.

14.5.9 Remove the gas tap fixing nut.

14.5.10 Disconnect the two burner wiring loom leads from the solenoid unit.

14.5.11 Disconnect the earth lead from the solenoid unit.

14.5.12 Pull the tap & solenoid unit clear.

14.5.13 To separate the tap from the solenoid, detach the solenoid unit at the gas tap end

14.5.14 Replace in the reverse order.

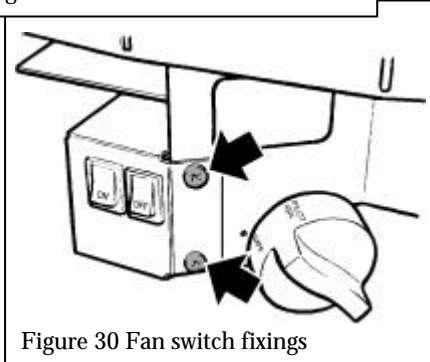

Figure 30 Fan switch fixings

14.6 To Remove The Piezo Generator

14.6.1 Remove the gas tap & solenoid unit as sections 14.5.1 to 14.5.12.

14.6.2 Make sure that the tap is in the off position.

14.6.3 Remove the circlip holding the piezo unit to the tap. Remove the piezo unit.

14.6.4 Replace in the reverse order.

14.7 To Remove The Main Burner Injector

14.7.1 Detach the burner unit from the convection box as section 14.4.

14.7.2 Disconnect the main burner pipe from the injector. If necessary, loosen the pipe at the gas tap end to swing the pipe clear of the injector.

14.7.3 Unscrew the injector from the support bracket.

14.7.4 Refit in the reverse order. Make sure that no leads are trapped.

14.8 To Remove an “On” or “Off” Fan Switch

14.8.1 Detach the fan switch bracket from the burner control bracket by removing two screws (see figure 30). Carefully pull clear of the burner unit.

14.8.2 Detach the two leads from the switch which is to be removed.

14.8.3 Press in the plastic spring grips at the ends of the switch and pull the switch clear of the bracket.

14.8.4 Replace in the reverse order. Make sure the correct leads go to each switch (see wiring diagram figure 15). Make sure that no leads are trapped.

14.9 To Gain Access to the Electrical Control Components

14.9.1 Remove the burner unit - See section 14.4.

14.9.2 Detach the control unit from the convection box left side flange by removing two screws (see figure 31). Carefully pull the unit slightly forward.

14.9.3 Detach the fan wiring loom connection. (see figure 32).

14.9.4 Detach the plastic vacuum tube from the metal vacuum pipe (see figure 32).

14.9.5 Detach the control unit cover by removing one screw (see figure 33).

14.9.6 The control unit can be pulled forward as far as the slack in the mains lead will allow. **Do not stress the mains lead.**

14.9.7 When replacing the unit make sure that all the leads are correctly and firmly connected (see wiring diagram figure 15), that no leads are trapped and that the vacuum tube is firmly connected.

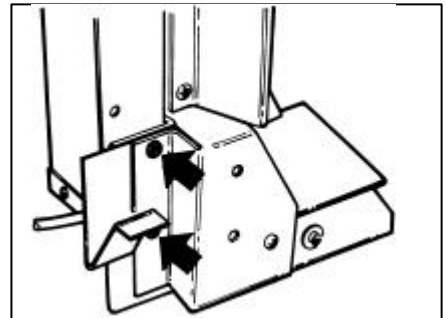

Figure 31 Electrical control unit fixings

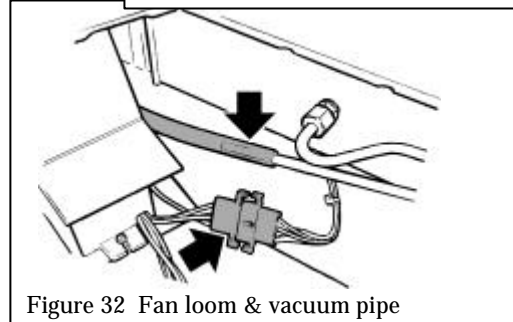

Figure 32 Fan loom & vacuum pipe

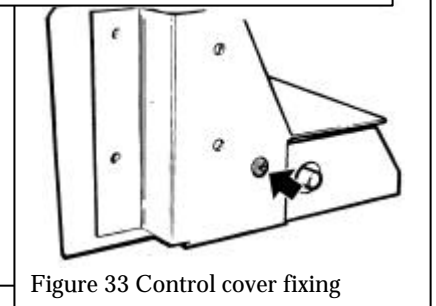

Figure 33 Control cover fixing

14.10 To Remove the Distribution block

14.10.1 To gain access see section 13.9.

14.10.2 Remove the two screws fixing the block to the control bracket.

14.10.3 Disconnect the earth lead from the control bracket.

14.10.4 Remove the pressure switch cover (figure 34). Disconnect the three leads (Yellow, orange & white) from the air pressure switch.

14.10.5 Disconnect the two leads (Brown & blue) from the mains cable connection block.

14.10.6 Replace in the reverse order. Make sure that all the leads are correctly and firmly connected (see wiring diagram figure 15), that no leads are trapped and that the vacuum tube is firmly connected.

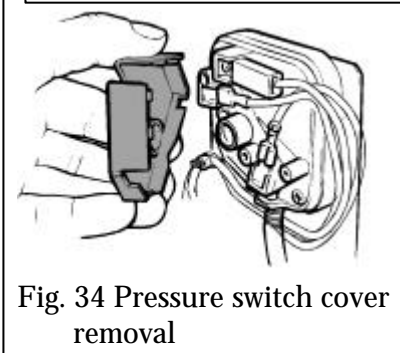

Fig. 34 Pressure switch cover removal

14.11 To Remove the Air Pressure Switch

14.11.1 To gain access see section 13.9.

14.11.2 Detach the pressure switch from the control bracket by removing two screws, nuts and shakeproof washers (see figure 35).

14.11.3 Remove the pressure switch cover (figure 34). Disconnect the three leads (Yellow, orange & white) from the air pressure switch.

14.11.4 Detach the plastic vacuum tube from the pressure switch.

14.11.5 Replace in the reverse order. When replacing make sure that the vacuum tube is connected to the shank on the pressure switch closest to the centre of the appliance (marked ) - not the shank closest to the control bracket. Firmly attach the tube at both ends.

Make sure that all the leads are correctly and firmly connected (see wiring diagram figure 15) and that no leads are trapped.

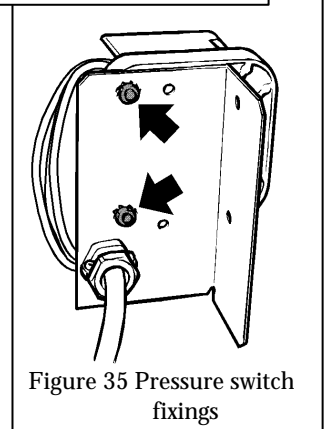

Figure 35 Pressure switch fixings

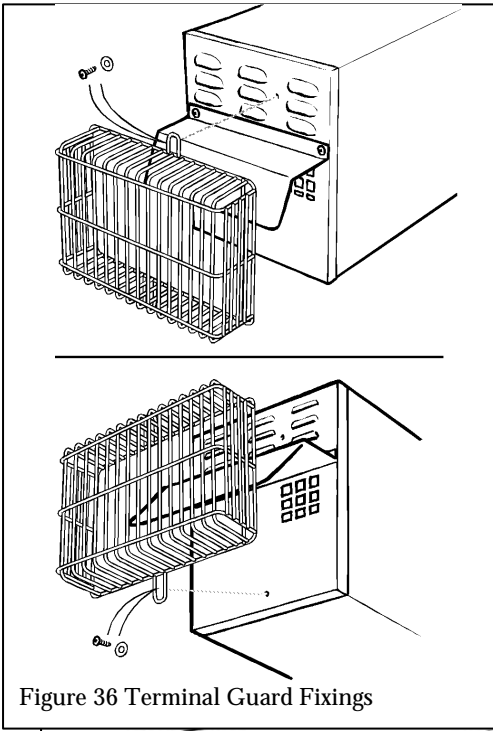

Figure 36 Terminal Guard Fixings

14.12 To Remove the Fan

14.12.1 Remove the terminal guard by detaching two screws and washers (figure 36).

14.12.2 Detach the weather shield and flue box end plate by removing two screws (figure 37).

14.12.3 Disconnect the wiring loom connector inside the top right of the flue box (figure 38).

14.12.4 Slide the fan out of the flue box (figure 38).

14.12.5 Replace in the reverse order.

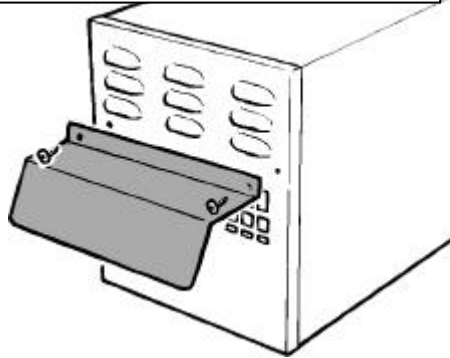

Figure 37 Weather Shield Fixings

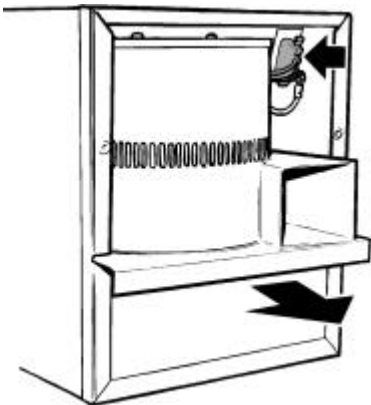
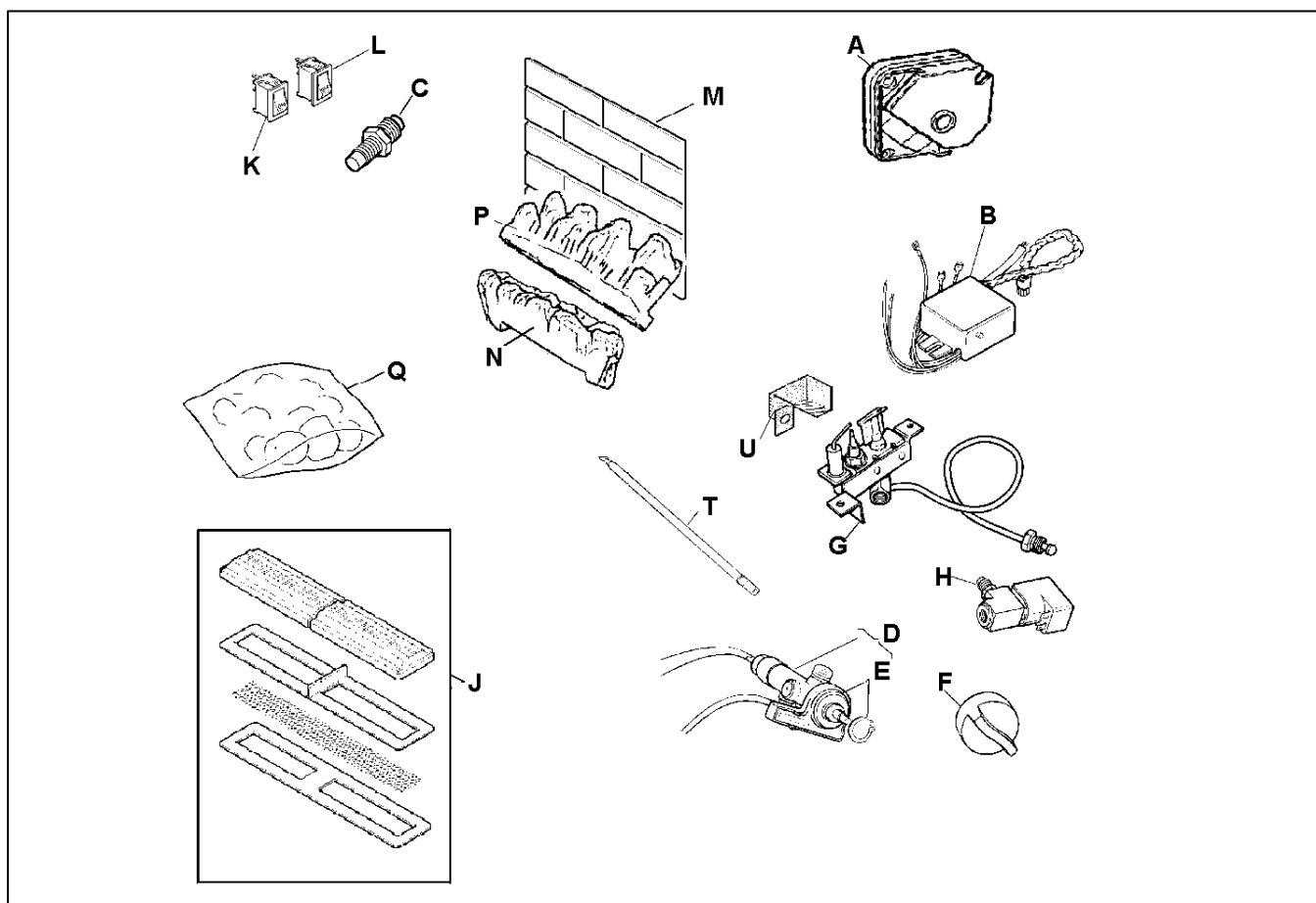

Figure 38 Fan removal

SHORT LIST OF SPARES



Key No.	Description	No. off	Part No.
A	Air pressure switch	1	560969
B	Electrics control unit	1	559709
C	Injector Bray cat 18 size 360 - <i>For Natural Gas Appliances</i>	1	541609
	Injector Bray cat 18 size 170 - <i>For Propane Appliances</i>		571709
D	Gas tap & spark generator	1	545969
E	Spark generator	1	521069
F	Control knob	1	545979
G	Pilot unit - <i>For Natural Gas Appliances</i>	1	540979
	Pilot unit - <i>For Propane Appliances</i>		544929
H	Solenoid valve	1	559719
J	Burner plaque & gasket set	1	569439
K	"On" switch	1	559729
L	"Off" switch	1	559739
M	Ceramic rear wall	1	545999
N	Front coal	1	9770074
P	Rear base coal	1	9770075
Q	Pack of loose coals	1	9780033
T	Smoke match tube	1	541169
U	Dust Cage	1	567619

All Wonderfire appliances are CE Approved and designed to meet the appropriate British Standards.



All Wonderfire appliances are manufactured to the highest standards of quality and excellence under the BS EN ISO 9001 quality system accepted by the British Standards Institute.

All Wonderfire gas appliances must be installed by a competent person in accordance with the Installer Guide. If in doubt always use the services of a CORGI Registered Installer

Please fill in the following information for your own future reference. The information should always be quoted in any correspondence with your original supplier or Wonderfire service department.

In the United Kingdom please telephone **0121 386 6203**.

In the Republic of Ireland please telephone **353 183 75114**

Model	BR517R
Front	Lincoln
Supplier's Name	
Supplier's Address	
Telephone No.	
Date of Purchase	
Guarantee Card No.	



MANUFACTURED BY WONDERFIRE
Wood Lane, Erdington, Birmingham B24 9QP

Because our policy is one of constant development and improvement, details may vary slightly from those given in this publication