

Baxi Barcelona

Wall Mounted Powered Flue Condensing Boiler
Gas Fired Central Heating Unit

Installation and Servicing Instructions

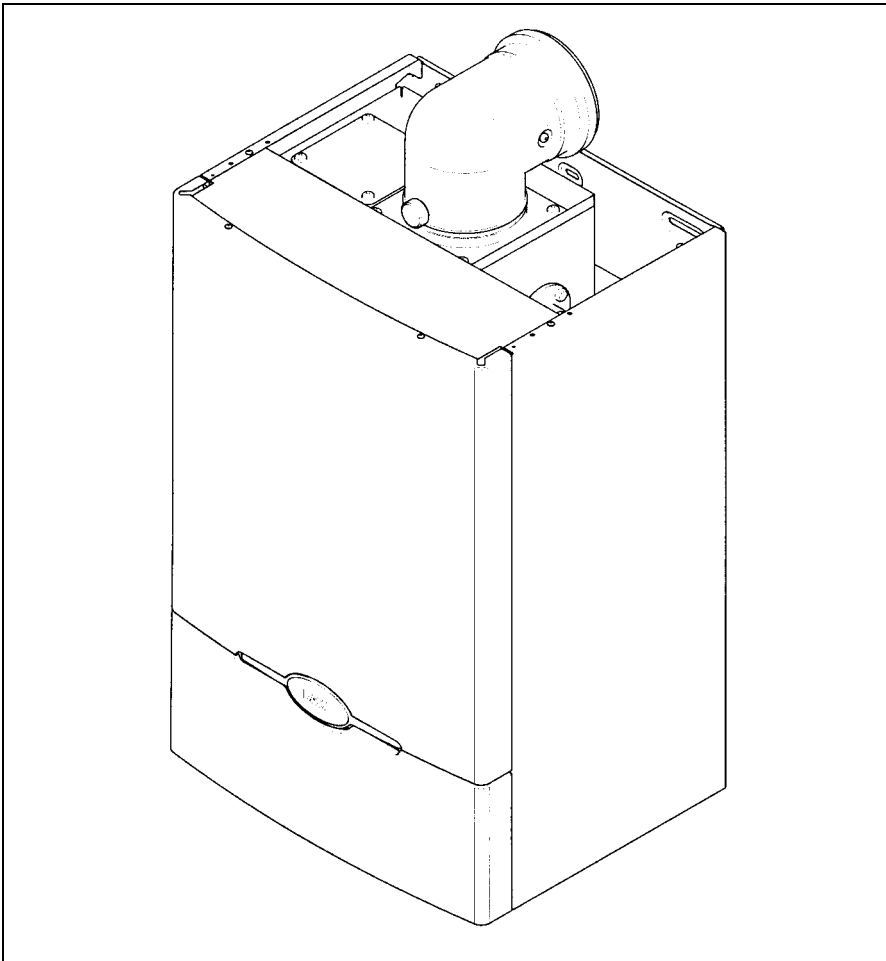

BAXI

Natural Gas

Baxi Barcelona
G.C.Nº 41 075 02

Baxi Limited is one of the leading manufacturers of domestic heating products in the UK.

Our first priority is to give a high quality service to our customers. Quality is designed into every Baxi product - products which fulfil the demands and needs of customers, offering choice, efficiency and reliability.

To keep ahead of changing trends, we have made a commitment to develop new ideas using the latest technology - with the aim of continuing to make the products that customers want to buy.

Baxi is also the largest manufacturing partnership in the country. Everyone who works at the company has a commitment to quality because, as shareholders, we know that satisfied customers mean continued success.

We hope you get a satisfactory service from Baxi. If not, please let us know.

The boiler meets the requirements of Statutory Instrument "The Boiler (Efficiency) Regulations 1993 Nº 3083" and is deemed to meet the requirements of Directive 92/42/EEC on the energy efficiency requirements for new hot water boilers fired with liquid or gaseous fuels:-

Type test for purpose of Regulation 5 certified by:
Notified Body 0086.

Product/Production certified by:
Notified Body 0086.

For GB/IE only.



Baxi is a BS-EN ISO 9001
Accredited Company

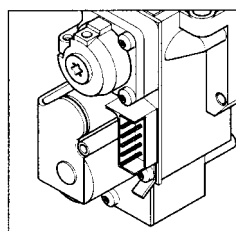
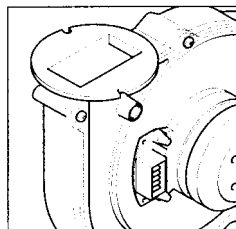
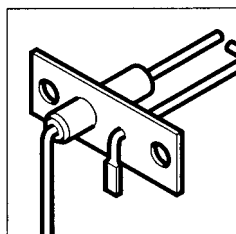

| Section | | Page |
|---------|--------------------------|------|
| 1.0 | Introduction | 4 |
| 2.0 | General Layout | 5 |
| 3.0 | Appliance Operation | 6 |
| 4.0 | Technical Data | 7 |
| 5.0 | Dimensions and Fixings | 8 |
| 6.0 | System Details | 9 |
| 7.0 | Site Requirements | 12 |
| 8.0 | Installation | 16 |
| 9.0 | Electrical | 22 |
| 10.0 | Commissioning the Boiler | 24 |
| 11.0 | Fitting the Outer Case | 25 |
| 12.0 | Servicing the Boiler | 26 |
| 13.0 | Changing Components | 28 |
| 14.0 | Short Parts List | 35 |
| 15.0 | Fault Finding | 36 |

Fig.1

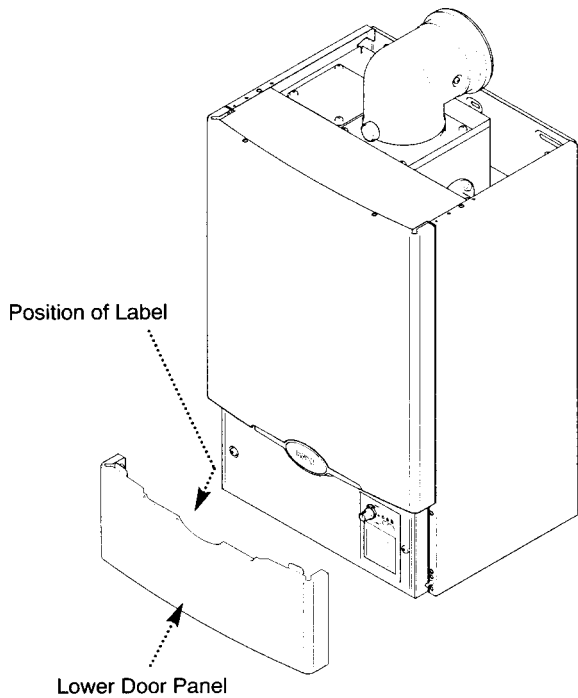
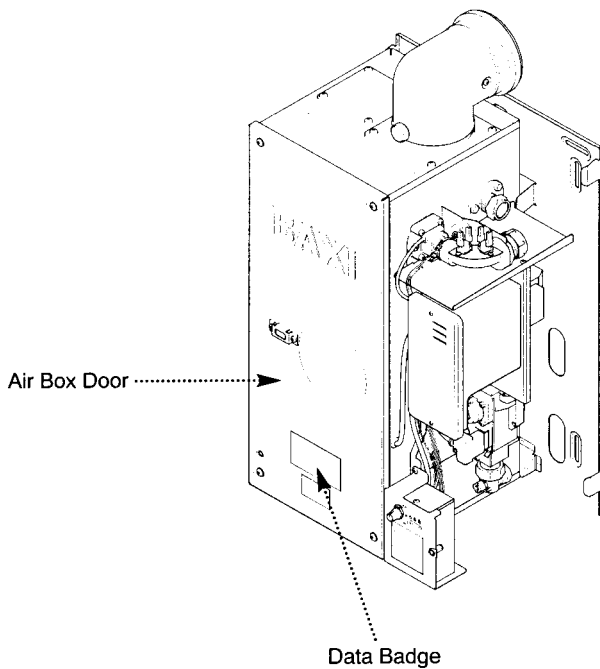

Fig. 2



Baxi Limited declare that no substances harmful to health are contained in the appliance or used during appliance manufacture.

NOTE: This appliance must be installed in accordance with the manufacturer’s instructions and the regulations in force, and only used in a suitably ventilated location.

All systems must be thoroughly flushed and treated with inhibitor (see Section 6.2).

Read the instructions fully before installing or using the appliance

1.1 Description

1. The Baxi Barcelona is a gas fired room sealed fan assisted condensing central heating boiler.
2. The maximum output of the boiler is preset at 80,000 Btu/hr. The boiler will automatically adjust down to 30,000 Btu/hr according to the system load. If required, the output can be set to 100,000 Btu/hr. Please refer to section 8.8.
3. It is designed for use on Natural Gas (G20).
4. The boiler is suitable for fully pumped open vented central heating and domestic hot water systems and sealed systems.
5. A label giving details of the model, serial number and Gas Council number is situated on the rear of the lower door panel (Fig. 1).
6. The boiler data badge is positioned on the air box door (Fig. 2).
7. The boiler is intended to be installed in residential / commercial / light industrial E.M.C. environments on a governed meter supply only.
8. The boiler must be installed with one of the purpose designed flues such as the standard horizontal flue kit, part n° 236921.

1.2 Important Information

This product contains Refractory Ceramic Fibres (R.C.F.) which are man-made vitreous silicate fibres. Excessive exposure to these materials may cause temporary irritation to eyes, skin and respiratory tract. Care must be taken when handling these articles to ensure the release of dust or fibres is kept to a minimum.

To ensure that the release of fibres from these articles is kept to a minimum, during installation and servicing it is recommended that a HEPA. filtered vacuum is used to remove any dust, soot or other debris accumulated in and around the appliance. This should be performed before and after working on the installation.

It is recommended that any replaced item(s) are not broken up but sealed within heavy duty polythene bags and clearly labelled “R.C.F. waste”. This is not classified as “hazardous waste” and may be disposed of at a tipping site licensed for the disposal of industrial waste.

Protective clothing is not required when handling these articles but it is recommended that gloves are worn and the normal hygiene rules of not smoking, eating or drinking in the work area are followed and always wash hands before eating or drinking.

“Benchmark” Log Book

As part of the industry-wide “Benchmark” initiative all Baxi boilers now include an Installation, Commissioning and Service Record Log Book. Please read the Log Book carefully and complete all sections relevant to the appliance and installation. These include sections on the type of controls employed, flushing the system, burner operating pressure etc. The details of the Log Book will be required in the event of any warranty work. Also, there is a section to be completed at each subsequent regular service visit.

2.0 General Layout – page 5

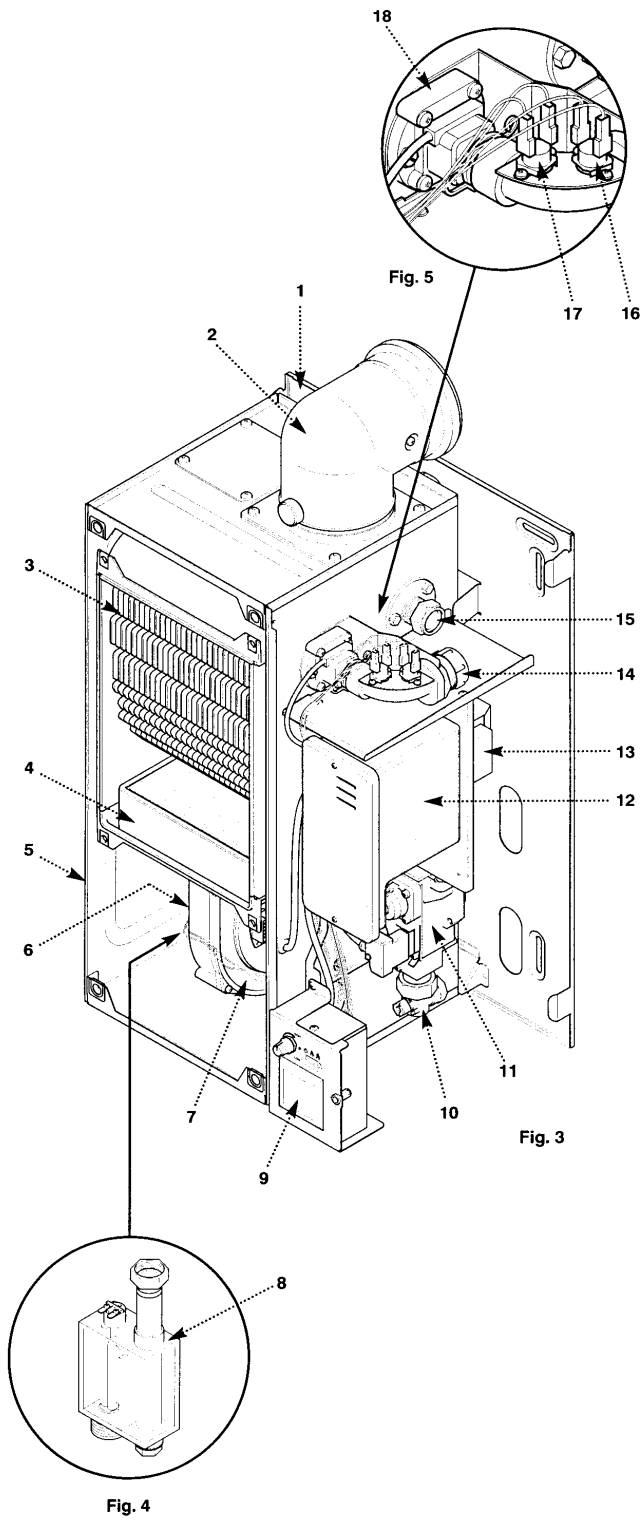

2.1 Layout (Figs. 3,4 & 5)

1. Wall Plate
2. Flue Elbow
3. Heat Exchanger
4. Burner
5. Air Box
6. Fan Protection Thermostat
7. Fan Assembly
8. Condensate Trap
9. User Interface (optional timer available)
10. Gas Tap
11. Gas / Air Ratio Valve
12. Electronics Housing
13. Transformer
14. Flow Pipe Connection
15. Return Pipe Connection
16. Flow Temperature Safety Thermostat - Black
17. Flow Temperature Thermistor - Red
18. Flow Switch (dry fire protection)

2.2 Optional Extras

| KIT | PART N° |
|--|---------|
| FLUE EXTENSION KITS (110/70) | |
| Flue Extension 0.25M | 241692 |
| Flue Extension 0.5M | 241694 |
| Flue Extension 1 M (Use two kits for 2M etc.) | 241695 |
| Flue Bend x 2 – 45° (Reduce overall length of flue by 0.5m when fitting this bend) | 241689 |
| Flue Bend – 90° (Reduce Overall length of flue by 1m when fitting each bend) | 241687 |
| VERTICAL FLUE (110/70) | |
| Vertical Flue Terminal | 242802 |
| Vertical Boiler Connection | 242886 |
| CONTROL ACCESSORIES | |
| Integral Electronic Twin Channel Timer Kit | 242834 |

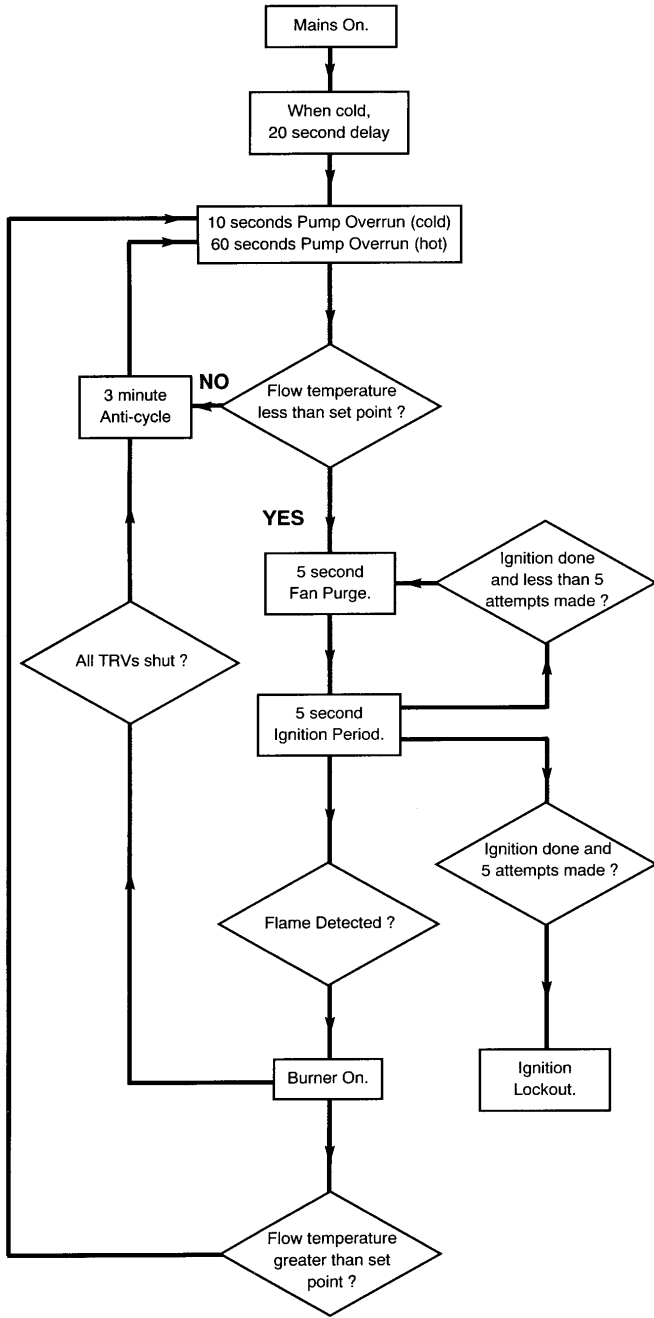

3.1

1. **Pump Overrun:** When the switched live to the boiler switches on or the flow temperature is greater than the set point or anti-cycle finishes then Pump Overrun occurs for 10 seconds (cold) or 60 seconds (hot). The pump is on while the fan, spark generator and gas valve are off.
2. **Fan Purge:** When pump overrun has finished if the flow temperature is less than that set on the thermostat knob then Fan Purge occurs. The pump and fan are on while the spark generator and gas valve are off.
3. **Ignition:** When fan purge has finished Ignition occurs. The pump, fan, spark generator and gas valve are on. The burner ignites at mid rate.
4. **Burner On:** When a flame is detected during the ignition period then Burner On occurs. The pump, fan and gas valve are on while the spark generator is off. Flow temperature is controlled by varying the fan speed (and thereby the gas rate) to achieve optimum operation.
5. **Anti-cycle:** When all the TRVs shut down during Burner On or Pump Overrun finishes and flow temperature is greater than set point then Anti-cycle occurs. The pump, fan, spark generator and gas valve are switched off.
6. **Ignition Lockout:** When 5 ignition attempts have been made without a flame being detected then Ignition Lockout occurs. The pump, fan, spark generator and gas valve are switched off. The lockout light flashes once a second. The boiler can only be reset manually using the thermostat knob.
7. **No Water Flow:** When there is No Water Flow through the boiler (indicated by the flow switch) then a continuous cycle of Pump Overrun and Anti-cycle occurs.

4.0 Technical Data – page 7

| | | |
|--|---------------------|-----------------|
| Appliance Type | C ₁₃ | C ₃₃ |
| Appliance Category | CAT I _{2H} | |
| Heat Input | Max | Min |
| (see note) kW | 33.76 | 10.2 |
| Btu/h | 115,200 | 34,840 |
| Heat Output (Non Condensing 70° C Mean Water Temp) | Max | Min |
| kW | 29.30 | 8.79 |
| Btu/h | 100,000 | 30,000 |
| Heat Output (Condensing 40° C Mean Water Temp) | Max | Min |
| kW | 31.05 | 9.6 |
| Btu/h | 105,980 | 32,880 |
| Max Gas Rate (Natural Gas) (After 10 Mins) | | |
| Btu/hr | 100,000 | 80,000 |
| m ³ /h | 2.95 | 2.36 |
| ft ³ /h | 104.2 | 83.3 |
| Inlet Pressure at Gas Valve (Natural Gas) | | |
| Min | 18.1 mbar | |
| Max | 22.5 mbar | |
| | (see Section 10.1) | |
| Injector (Natural Gas) | | |
| | 6.3mm Diameter | |

| | | |
|--|------------|-------------|
| Nox Class | 5 | |
| Horizontal Flue Terminal Dimensions | Diameter | 110mm |
| | Projection | 150mm |
| Connections | | |
| Gas Supply | - | 1/2 in BSPT |
| Central Heating Flow | - | 28mm |
| Central Heating Return | - | 28mm |
| Condensate Drain | - | 1 in BSP |
| Outercase Dimensions | | |
| Overall Height Inc Flue Elbow | - | 750mm |
| Casing Height | - | 600mm |
| Casing Width | - | 390mm |
| Casing Depth | - | 320mm |
| Clearances | | |
| Both Sides | | 5mm Min |
| Above Casing | | 200mm Min |
| Below Casing | | 130mm Min |
| Front (For Servicing) | | 500mm Min |
| Front (In Operation) | | 5mm Min |
| Weights | kg | lb |
| Packaged Boiler Carton | 40.7 | 89.6 |
| Packaged Flue Kit | 3.6 | 8.0 |
| Weight Empty | 38.2 | 84.1 |
| Installation Lift Weight | 31.5 | 69.3 |
| Recommended System Temperature Drop | | |
| Normal | 11°C | 20°F |
| Condensing | 20°C | 36°F |

| | |
|---------------------------------------|---|
| Electrical Supply | 230V~ 50Hz |
| | (Appliance must be connected to an earthed supply) |
| Power Consumption | 80W |
| External Fuse Rating | 3A |
| Internal Fuse Rating (BS 4265) | |
| Fuse (2) | 4 AT (Control Board) |
| Fuse (3) | 2 AT (Ignition Board) |
| Water Content | |
| litres | 2.6 |
| pints | 4.6 |
| Static Head | |
| max | 30 metres (100 ft) |
| min | 1 metre (3.25 ft) |
| Low Head | 0.2m (8 in) min |
| System Detail | fully pumped open vented & sealed systems |
| Gas Connection | RC1/2 (1/2 in BSPT) |
| Controls | boiler thermostat, safety thermostat, flow switch, electronic flame sensing, temperature protection thermostat & condensate blockage sensor |

NOTE: The maximum output of the boiler is factory set at 23.45kW (80,000 Btu/hr). This can be altered to 29.30kW (100,000 Btu/hr) - see section 8.8.

SEDBUK Declaration For Barcelona

The efficiency is 90.7%

This value is used in the UK Government's Standard Assessment Procedure (SAP) for energy rating of dwellings. The test data from which it has been calculated has been certified by 0086.

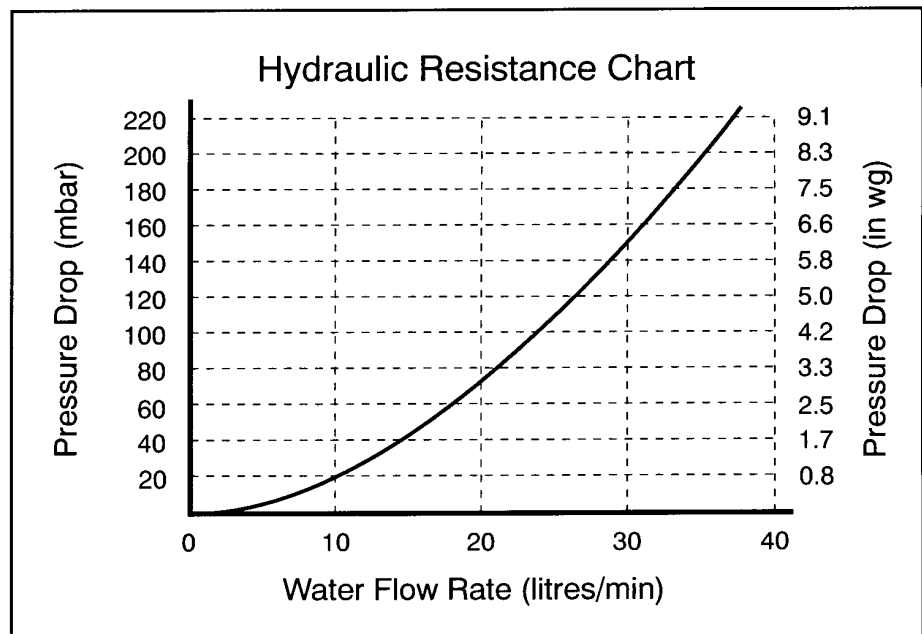
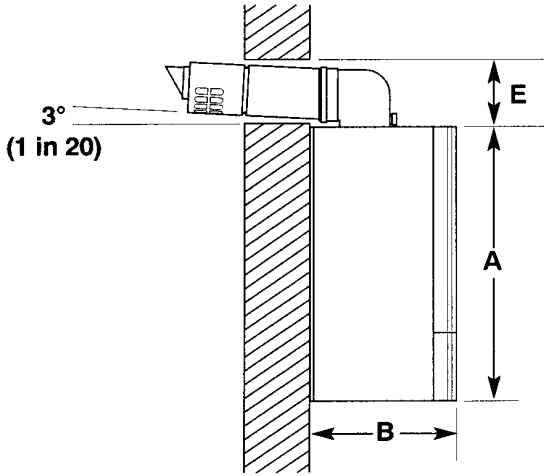
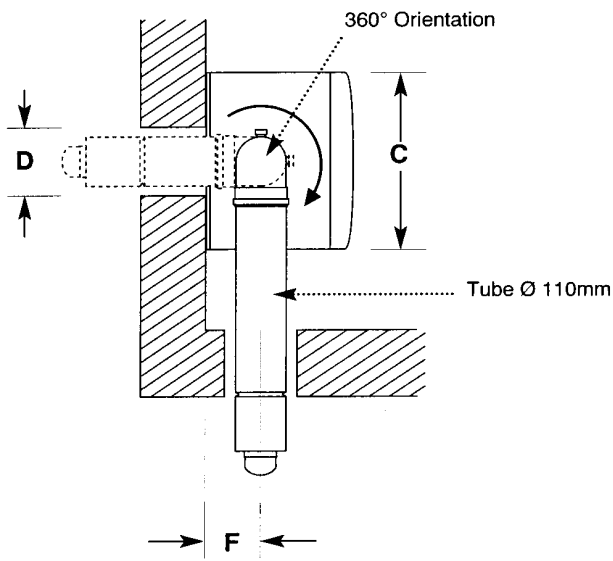

Fig. 6



| DIMENSIONS | |
|------------|--------------|
| A | 600mm |
| B | 320mm |
| C | 390mm |
| D | 125mm Ø Min. |
| E | 150mm |
| F | 125mm |



The 3° (1 in 20) fall provided by the elbow is to allow condensate to run back to the boiler, for disposal through the condensate discharge pipe.

Fig 7

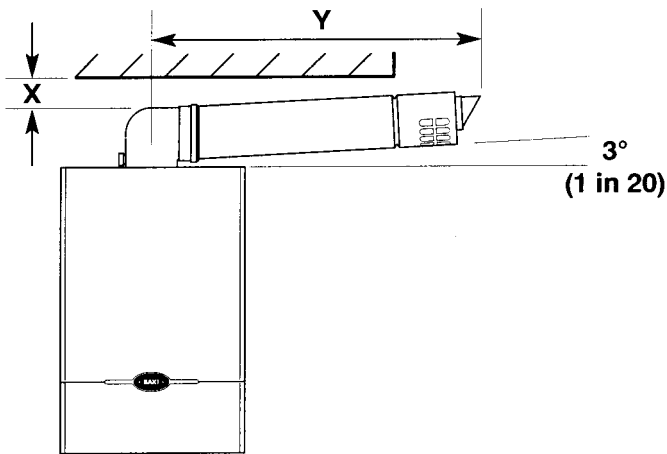

SIDE FLUE (left and right)
 For every 1 m of horizontal flue length, the clearance above the top of the flue elbow should be 55mm to incorporate the 3° (1 in 20) fall in the flue from the terminal to the elbow.

| Flue length (Y) | Clearance (X) |
|-----------------|---------------|
| Up to 1m | 55mm |
| 1m-2m | 110mm |
| 2m-3m | 165mm |

Fig. A Wiring to the pump feed connection of boiler

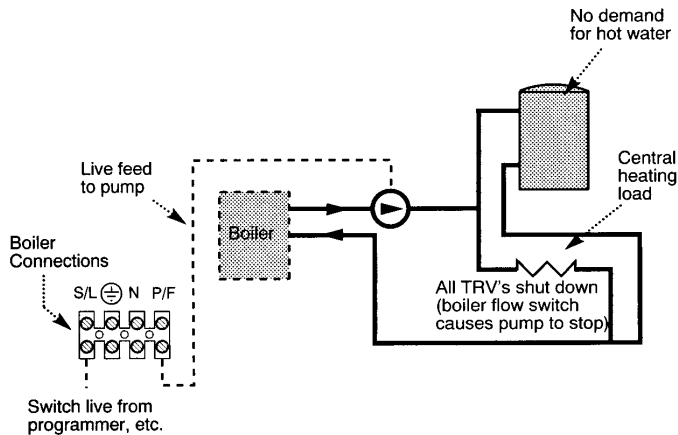

6.1 Water Circulating Systems

1. The appliance is suitable for use with open vent fully pumped systems and sealed systems.

The following conditions should be observed on all systems:

- The static head must not exceed 30m (100ft) of water.
- The boiler must not be used with a direct cylinder.
- Drain cocks should be fitted to all system low points.
- All gas and water pipes and electrical wiring must be installed in a way which would not restrict the servicing of the boiler.
- Position isolating valves as close to circulating pump as possible.
- It is recommended that the return pipe is fitted with an automatic air vent as close to the boiler as is practical.

NOTE: Full TRV Systems (refer to section 6.4) Where all the radiators are controlled by TRV's then pump protection will be required. This can be done by either of the options opposite (see Fig A & B). **The option shown in Fig. A should only be used on a full TRV system without a bypass. Fig. B shows a system with a bypass that must be capable of allowing a flow of at least 3 l/mm.**

6.2 Treatment of Water Circulating Systems

- All recirculatory water systems will be subject to corrosion unless an appropriate water treatment is applied. This means that the efficiency of the system will deteriorate as corrosion sludge accumulates within the system, risking damage to pump and valves, boiler noise and circulation problems.
- When upgrading existing systems that exhibit evidence of sludging, it is advisable to clean the system prior to treatment in order to remove any sludge and reduce the likelihood of these deposits damaging new components.
- When fitting new systems flux will be evident within the system, which can lead to damage of system components.
- All systems must be thoroughly drained and flushed out. The recommended flushing and cleansing agents are Betz-Dearborn Sentinel X300 or X400 and Fernox Superfloc Universal Cleanser which should be used following the flushing agent manufacturer's instructions.
- System additives - corrosion inhibitors and flushing agents/descalers should be suitable for aluminium and comply to BS7593 requirements. The only system additives recommended are Betz-Dearborn Sentinel X100 and Fernox-Copal which should be used following the inhibitor manufacturer's instructions.

Failure to flush and add inhibitor to the system will invalidate the appliance warranty.

- It is important to check the inhibitor concentration after installation, system modification and at every service in accordance with the manufacturer's instructions. (Test kits are available from inhibitor stockists.)
- For information or advice regarding any of the above contact the Baxi Helpline.

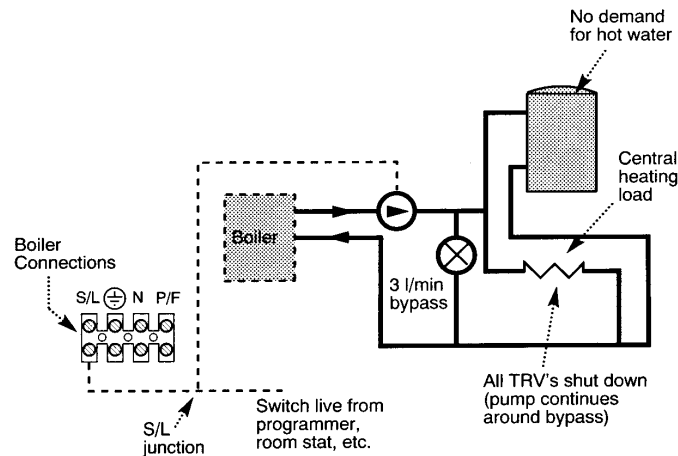

Fig. B Providing a 3 l/mm bypass

Fig. 7a

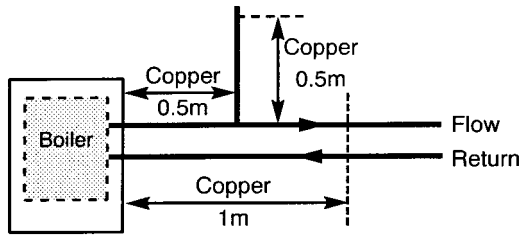

Fig. 8 Typical Low Head Installation

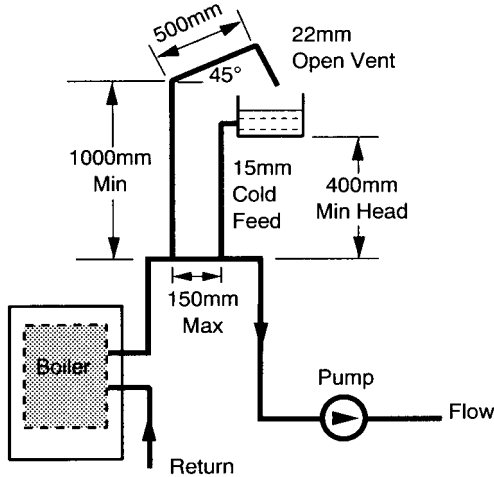

Fig. 9 If Conditions Require, This System Possible

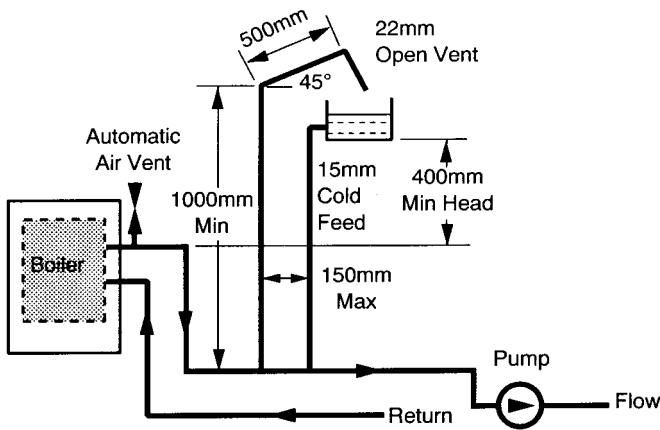
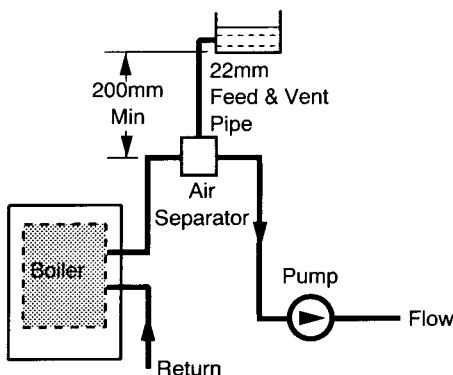

Fig. 10 Alternative Low Head Installation



6.3 Pipework

1. The sizes of flow and return pipes from the boiler should be determined by normal methods, according to the requirements of the system. The connection to the boiler is 28mm (compression).
2. Due to space requirements within the boiler outer case, pipework should comprise of solder fittings.
3. A 20°C (36°F) drop in temperature across the system is recommended for condensing boilers. Existing radiators may be oversized and so allow this, but where radiator sizing is marginal it may be advisable to retain a system temperature drop of 11°C (20°F).
4. In systems using non-metallic pipework it is necessary to use copper pipe for the boiler Flow and Return. The copper must extend at least 1 metre from the boiler and include any branches (Fig. 7a).

6.4 System Controls

1. For optimum operating conditions, the heating system into which the boiler is installed should include a control system.
2. Such a system will comprise of a timer control and separate room or cylinder thermostats as appropriate. (An integral twin channel programmer is available as an optional extra).
3. The boiler should be controlled so that it operates on demand only.
4. Operation of the system under control of the boiler thermostat & TRV's only does not produce the best results.

6.5 Low Head Installation

1. Using a close couple arrangement the minimum head is as shown in the diagrams (Figs. 8 & 9) subject to the following conditions:
 - a) The pump being adjusted to give an 20°C drop across the boiler.
 - b) The pump must be fitted on the flow.
 - c) The pump must be fitted in accordance with the pump manufacturers instructions.
 - d) The open vent pipe must be taken up from a tee in a horizontal section of the flow pipe.

An alternative Low Head Installation (Fig. 10)

2. For heads below 400mm then a combined vent and feed pipe may be connected. This must be a minimum of 22mm diameter. It is recommended that an air separator is fitted when using a combined feed and vent pipe.

6.6 Thermal Stores

1. The Barcelona must not be fitted to thermal stores which override the boiler control system.

Fig 11

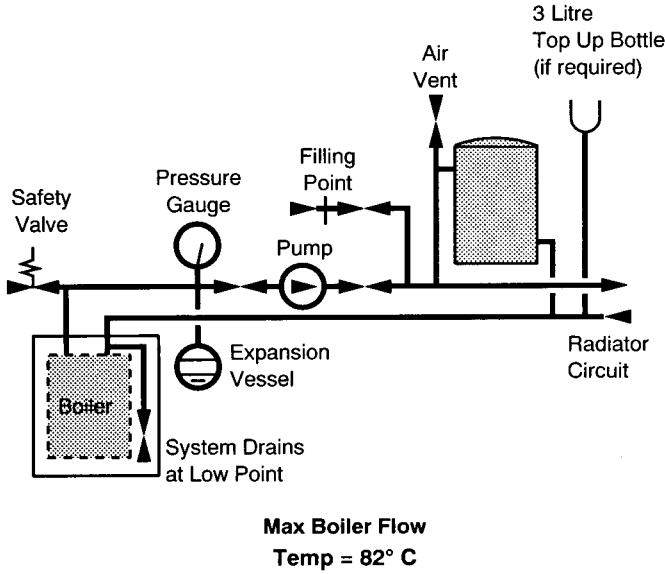

Table 1

Method of determining minimum value of expansion vessel volume for sealed systems using Baxi Boilers

| Vessel Charge Pressure (Bar) | Initial System Pressure (Bar) | Multiply Total Water Content Of System By (Litres) |
|------------------------------|-------------------------------|--|
| 0.5 | 0.5 | 0.067 |
| | 1.0 | 0.112 |
| | 1.5 | 0.207 |
| | 2.0 | 0.441 |
| 1.0 | 1.0 | 0.087 |
| | 1.5 | 0.152 |
| | 2.0 | 0.330 |
| 1.5 | 1.5 | 0.125 |
| | 2.0 | 0.265 |

Example :- System Volume = 75 litres
 Vessel Charge Pressure = 1.0 bar
 Initial System Pressure = 1.5 bar
 Then :- 75 x 0.152 = 11.4 litres
 Expansion Vessel Volume

NOTE

Where a vessel of the calculated size is not obtainable then the next available larger size should be used.

6.7 Sealed Systems (Fig. 11)

- SAFETY VALVE** - A safety valve complying with the requirements of BS 6750 Part 1 must be fitted close to the boiler on the flow pipe by means of a horizontal or vertically upward connection with no intervening valve or restrictions and should be positioned to facilitate testing. The valve should be pre-set and non-adjustable to operate at a pressure of 3 bar (45 lbf/in²). It must be arranged to discharge any water or steam through a pipe to a safe outlet position.
- PRESSURE GAUGE** - A pressure gauge of minimum range 0-4 bar (0-60 lbf/in²) with a fill pressure indicator must be fitted to the system, preferably at the same point as the expansion vessel in an easily visible position.
- EXPANSION VESSEL** - An expansion vessel complying with the requirements of BS 4814 must be fitted to the system by means of a connection close to the inlet side of the circulating pump in accordance with the manufacturers instructions, the connecting pipe being unrestricted and not less than 15mm (½ in) nominal size. The volume of the vessel should be suitable for the system water content and the nitrogen or air charge pressure should not be less than the system static head (See Table. 1).

Further details of sealed system design can be obtained from BS 5449 and the British Gas publication entitled 'Specifications for Domestic Wet Central Heating Systems'.
- FILLING POINT** - A filling point and an approved stop valve to BS 1010 must be fitted at low level and the method used for filling the system should be approved by the local water undertaking. For further details see BS 6798.
- MAKE UP SYSTEM** - A method of replacing water lost from the system should be provided either by means of a make up vessel of not more than 3 litres (5 pints) capacity, mounted above the highest point of the system, or by re-pressurisation of the system.
- VENTING** - A method of venting the system during filling and commissioning must be provided by fitting automatic air vents or by venting manually.
- HOT WATER STORAGE** - The hot water storage vessel must be of the indirect coil type. All components used in the system must be suitable for operation at 110°C (230°F) and at the pressure allowed by the safety valve.

7.0 Site Requirements – page 12

Fig. 12

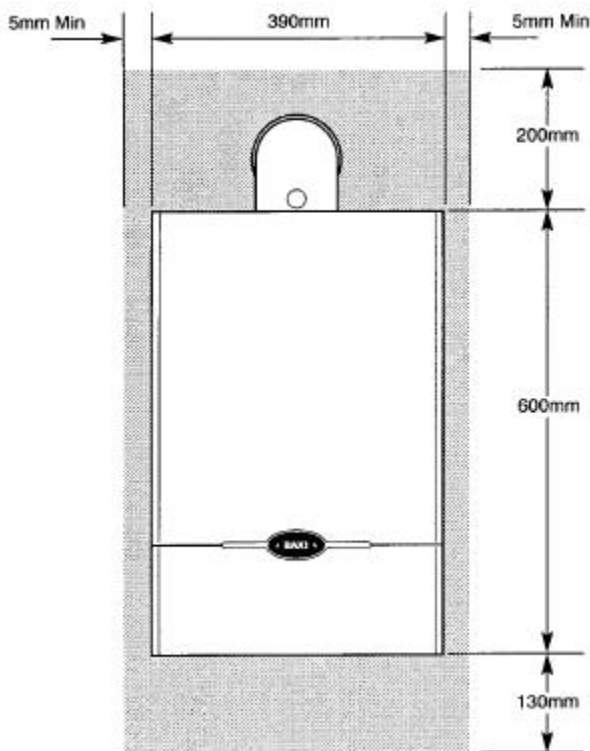

7.1 Information

WARNING - Check the information on the data plate is compatible with local supply conditions

1. The installation must be carried out by a CORGI Registered Installer or other registered competent person and be in accordance with the relevant requirements of the current **GAS SAFETY** (Installation and Use) **REGULATIONS**, the **BUILDING REGULATIONS** (Scotland)(Consolidation), the **LOCAL BUILDING REGULATIONS**, the **current I.E.E. WIRING REGULATIONS** and the bye laws of the **LOCAL WATER UNDERTAKING**. Where no specific instruction is given reference should be made to the relevant **BRITISH STANDARD CODES OF PRACTICE**. For Ireland install in accordance with IS 813 “**INSTALLATION OF GAS APPLIANCES**”. Reference should also be made to **BRITISH GAS GUIDANCE NOTES FOR THE INSTALLATION OF DOMESTIC GAS CONDENSING BOILERS**.

7.2 B.S. Codes of Practice

| Standard | Scope |
|----------------|---|
| BS 6891 | Gas Installation |
| BS 5546 | Installation of hot water supplies for domestic purposes. |
| BS 5449 Part 1 | Forced circulation hot water systems |
| BS 6798 | Installation of gas fired hot water boilers. |
| BS 5440 Part 1 | Flues |
| BS 5440 Part 2 | Ventilation |
| BS 7074 | Expansion vessels and ancillary equipment for sealed water systems. |
| BS 7593 | Treatment of water in domestic hot water central heating systems |

WARNING - The addition of anything that may interfere with the normal operation of the appliance without the express written permission of Baxi Limited could invalidate the appliance warranty and infringe the **GAS SAFETY** (Installation and Use) **REGULATIONS**.

Fig. 13

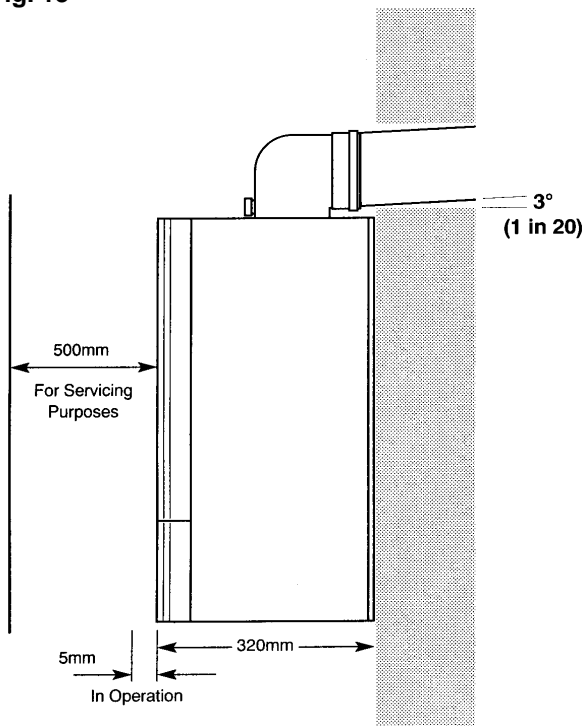

7.3 Clearances (Figs. 12 & 13)

1. A flat vertical area is required for the installation of the boiler.
2. These dimensions include the necessary clearances around the boiler for case removal, spanner access and air movement. Additional clearances may be required for the passage of pipes around local obstructions such as joists running parallel to the front face of the boiler.

7.4 Location

1. The boiler may be fitted to any suitable wall with the flue passing through an outside wall or roof and discharging to atmosphere in a position permitting satisfactory removal of combustion products and providing an adequate air supply. The boiler should be fitted within the building unless otherwise protected by a suitable enclosure i.e. garage or outhouse. (The boiler may be fitted inside a cupboard - see Section 7.5).
2. If the boiler is sited in an unheated enclosure then it is recommended to incorporate an appropriate device for frost protection in the system controls.
3. If the boiler is fitted in a room containing a bath or shower reference must be made to the current **I.E.E. WIRING REGULATIONS** and **BUILDING REGULATIONS**. If the boiler is to be fitted into a building of timber frame construction then reference must be made to the Institute of Gas Engineers document UP 7.

Fig14

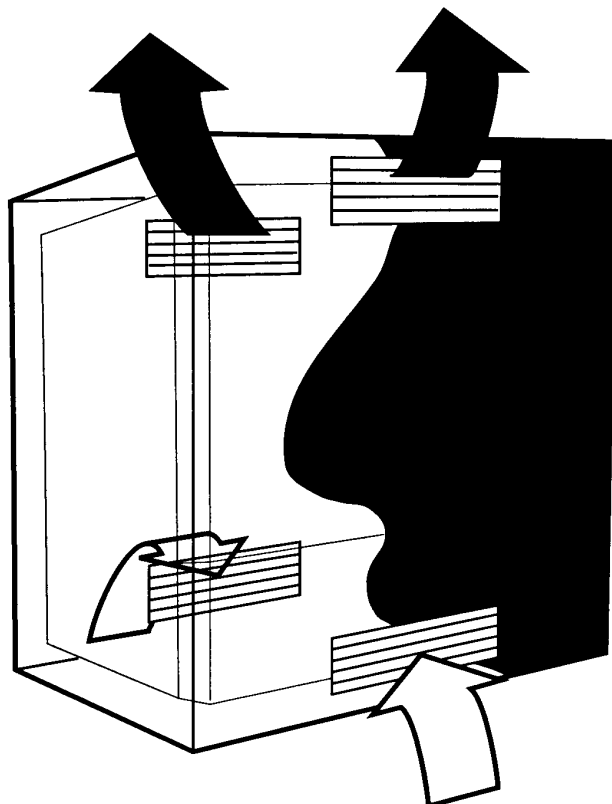

| Position of Air Vent | Air from Room | Air direct from Outside |
|----------------------|--|---|
| High | 306cm ² (49 in ²) | 153cm ² (24.5in ²) |
| Low | 306cm ² (49 in ²) | 153cm ² (24.5in ²) |

Fig. 15

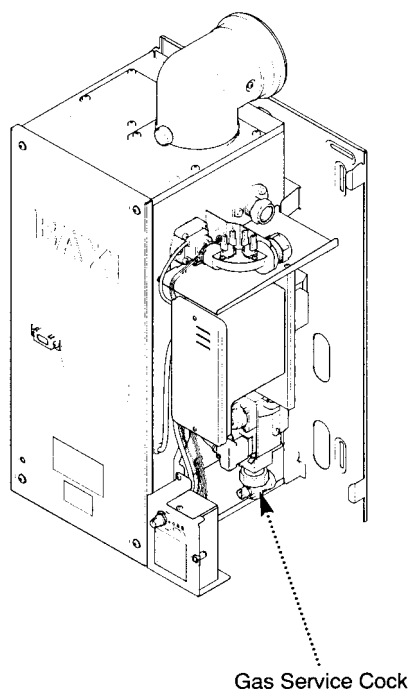

7.5 Ventilation of Compartments (Fig. 14)

1. Where the boiler is installed in a cupboard or compartment, air vents are required (for cooling purposes) in the cupboard or compartment at high and low level which may communicate with a room or direct to outside air.

NOTE: Both air vents must communicate with the same room or both be on the same wall to outside air

2. Detailed recommendations for air supply are given in BS 5440: Part 2.
3. An existing cupboard or compartment may be used, provided that it is modified for the purpose. Recommendations for air supplies and details of essential cupboard compartment design are given in BS 5440: Part 2.

7.6 Gas Supply

1. The gas installation should be in accordance with BS6891.
2. The connection to the appliance is a 1/2in BSPT internal threaded connection located at the rear of the gas service cock (Fig. 15).
3. Ensure that the pipework from the meter to the appliance is of adequate size. (22mm pipework must be connected to the appliance gas service cock. This should extend for at least 3 meters back towards the gas meter).

Do not use pipes of a smaller diameter than the boiler gas connection.

7.7 Electrical Supply

1. External wiring must be correctly earthed, polarised and in accordance with **current I.E.E. WIRING REGULATIONS**.
2. The mains supply is 230V ~ 50Hz fused at 3A.

NOTE: The method of connection to the electricity supply must facilitate complete electrical isolation of the appliance. Connection may be via a fused double-pole isolator with a contact separation of at least 3mm in all poles and servicing the boiler and system controls only.

7.8 Condensate Drain

NOTE: Ensure the discharge of condensate complies with any national or local regulations in force.

1. The condensate outlet terminates in a 1" BSP nut and seal for the connection of 21.5mm (3/4in) plastic overflow pipe which should generally discharge internally into the household drainage system. If this is not possible, discharge into an outside drain is acceptable.
2. The pipe should run internally as much as possible and with a 10° (1 in 6) fall to dispose of condensate quickly to avoid freezing.

Fig. 16

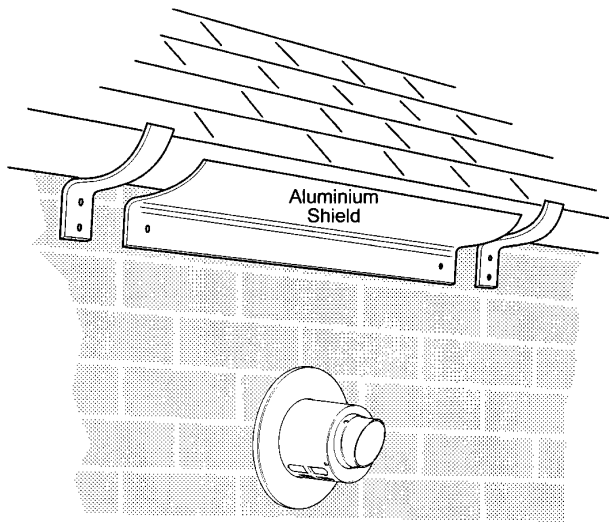

7.9 Flue

NOTE: Due to the nature of the boiler a plume of water vapour will be discharged from the flue. This should be taken into account when siting the flue terminal.

1. The following guidelines indicate the general requirements for siting balanced flue terminals. Recommendations for flues are given in BS 5440 Pt.1.
2. If the terminal is fitted within 1 metre (39 in) of a plastic gutter, within 500mm (19½ in) of a painted eave or a painted gutter, an aluminium shield of at least 1 metre (39 in) long should be fitted to the underside of the gutter or painted surface. An air space of 5mm (3/16 in) should be left between shield and gutter (Fig. 16).
3. If the terminal discharges onto a pathway or passageway, check that combustion products will not cause a nuisance and that the terminal will not obstruct the passageway.
4. Take into consideration the effect the plume of vapour may have on neighbours when siting the flue.
5. If a terminal is less than 2 metres (78¾ in) above a balcony, above ground or above a flat roof to which people have access, then a suitable terminal guard must be provided.

Fig. 17

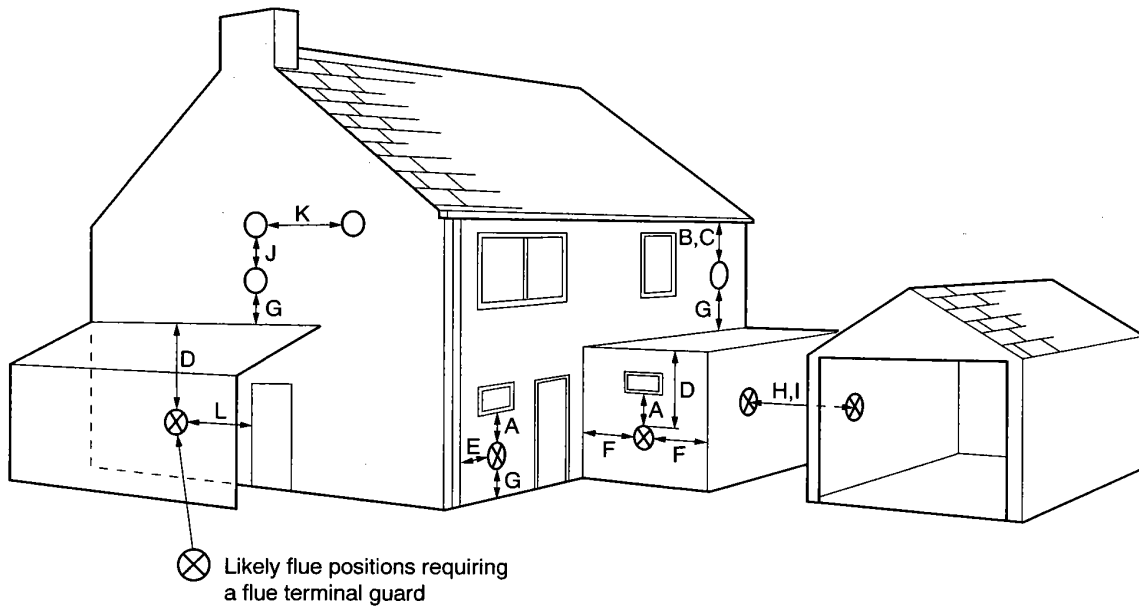

Terminal Position with Minimum Distance Fig 17

| | mm |
|--|-----------|
| A Directly below an openable window or other opening, e.g. an air brick. | 300 |
| B Below gutters, soil pipes or drain pipes. | 75 |
| C Below eaves. | 200 |
| D Below balconies or car port roof. | 200 |
| E From vertical drain pipes and soil pipes. | 75 |
| F From internal or external corners. | 300 |
| G Above ground, roof or balcony level. | 300 |
| H From a surface facing a terminal. | 600 |
| I From a terminal facing a terminal. | 1200 |
| J Vertically from a terminal on the same wall. | 1500 |
| K Horizontally from a terminal on the same wall. | 300 |
| L For an opening in a car port (e.g. door, window) into a dwelling. | 1200 |

Fig. 18

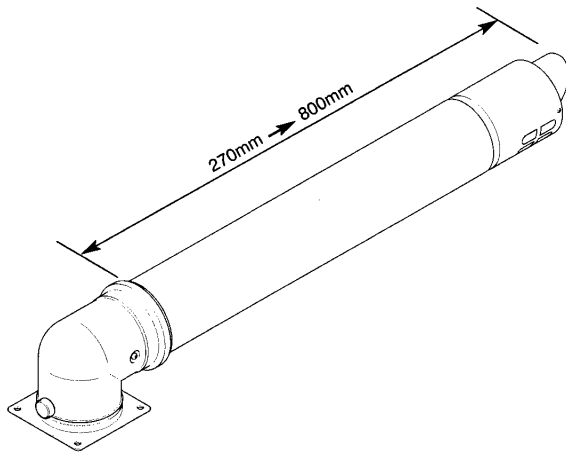

Fig 18a

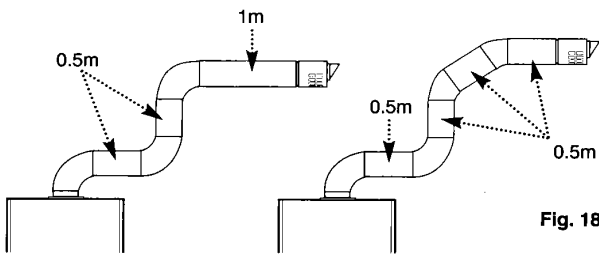
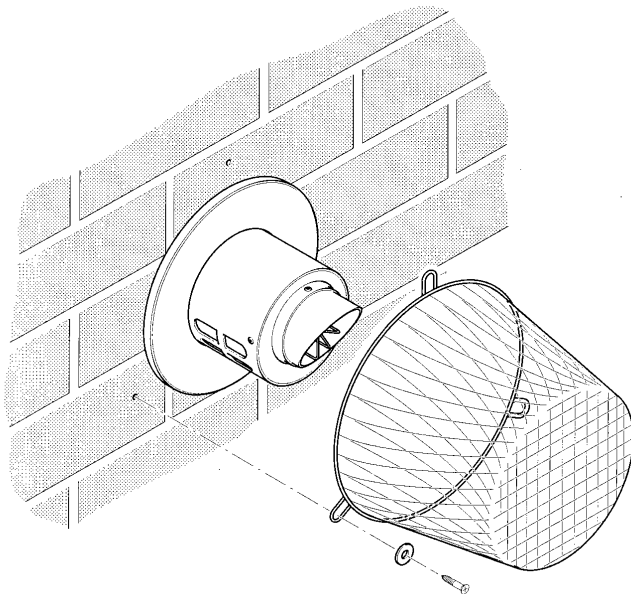

Fig. 18a

Pictorial examples of flue runs where EQUIVALENT flue length equals 4m

Fig. 19



7.10 Flue Dimensions

See Section 1.2. The standard horizontal flue kit allows for flue lengths between 270mm (10 5/8”) and 800mm (32”) from elbow to terminal (Fig. 18).

The maximum permissible equivalent flue length is: 4 metres (Fig. 18a).

NOTE: Each additional 45° of flue bend will account for an equivalent flue length of 0.5m
 eg. 45° = m, 90° = 2 x 45° = 1m etc.

7.11 Terminal Guard (Fig. 19)

1. When codes of practice dictate the use of terminal guards, they can be obtained from most Plumbers’ and Builders’ Merchants.
2. When ordering a terminal guard, quote the appliance model number.
3. The guard manufacturers listed below can be contacted for terminal sizes and guard model numbers.

Tower Flue Components Ltd.,
 Tower House,
 Vale Rise,
 Tonbridge,
 Kent.
 Tel: 01732 351555.

Quinnell, Barrett & Quinnell,
 884 Old Kent Road,
 London,
 SE15 1NL.
 Tel: 0171 639 1357.

4. The flue terminal guard should be positioned centrally over the terminal and fixed as illustrated

7.12 Vertical Flue

1. Only a flue approved with the Baxi Barcelona can be used.
2. For information on vertical flues consult the Baxi Barcelona Installer Guide or Notes for Guidance supplied with the vertical flue pack.

Fig. 20

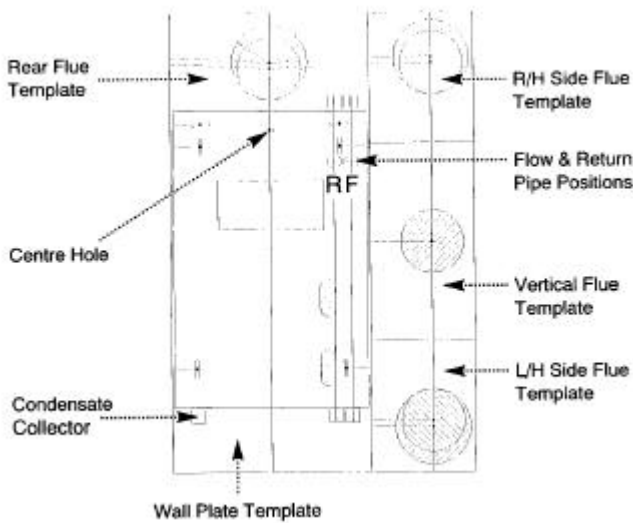

Check Site Requirements (section 7) before commencing.

8.1 Initial Preparation

The gas supply, gas type and pressure must be checked for suitability before connection (see Section 7.6).

NOTE: If the boiler wall plate is to be pre-hung, follow both these instructions and those on the boiler pack.

1. Remove the fixing template (Fig. 20) from the carton.
2. After considering the site requirements (see Section 7.0) position the template on the wall ensuring it is level both horizontally and vertically.
3. Mark the position of the centre hole for the wall plate (Fig. 20).
4. Mark the centre of the flue hole (rear exit). For side exit, mark as shown (Fig. 21). If required, mark the position of the gas and water pipes. Remove the template.
5. Cut the hole for the flue (minimum diameter 125mm, see table for wall thicknesses and flue diameters).
6. Drill and plug the wall as previously marked. Secure the wall plate using the centre hole.
7. Ensuring the wall plate is level both horizontally and vertically, drill and plug at least 4 securing positions at the top and bottom through the wall plate. Utilising the slots available ensure the wall plate is square and secure to the wall (Fig. 22).
8. Loosely route the condensate discharge pipe to the lower left hand side of the wall plate.

Fig. 21

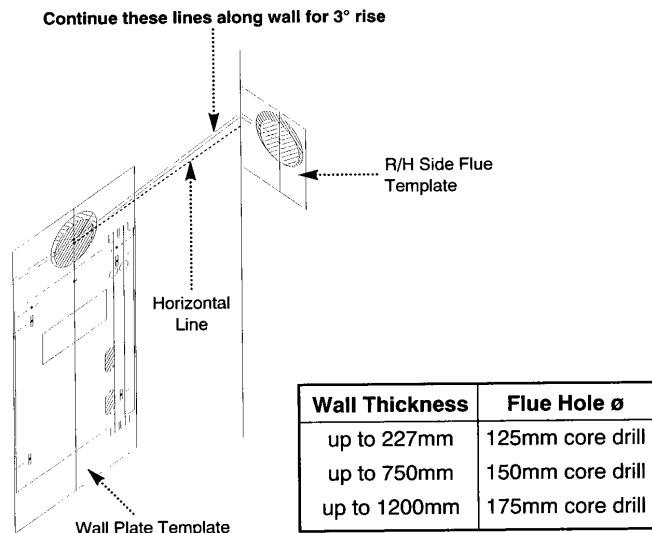

Fig. 22

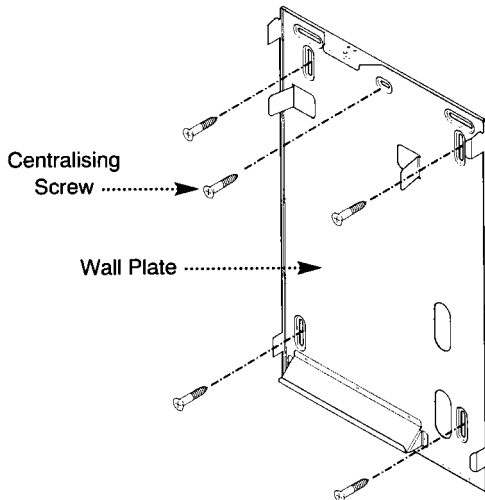
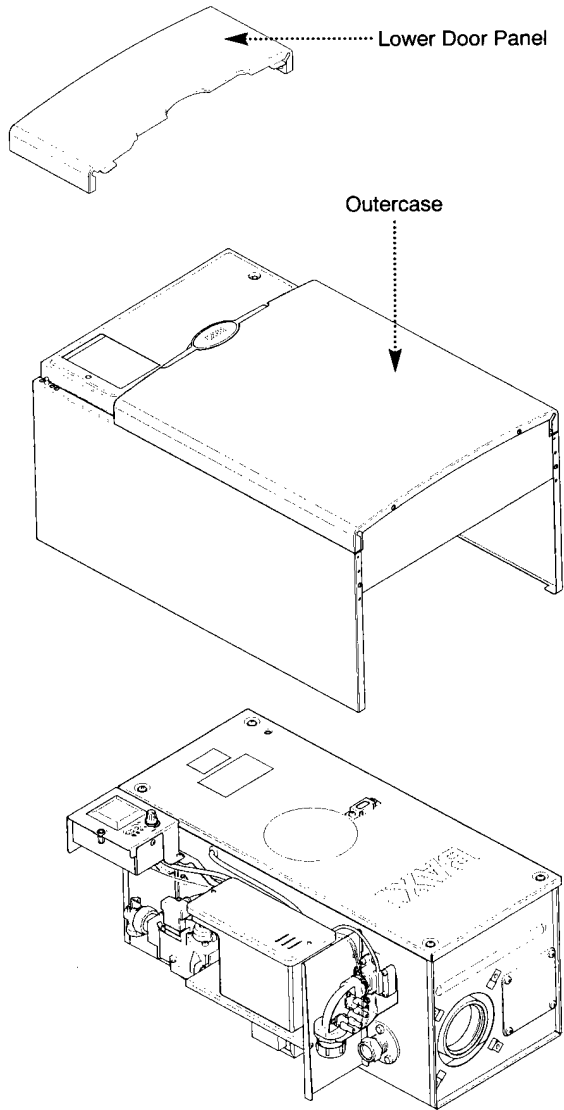

Fig. 23



8.2 Preparing The Boiler

1. Remove the outer carton.
2. Remove the internal packaging.
3. Lift the outercase upwards and remove (Fig. 23).

Baxi Limited declare that no substances harmful to health are contained in the appliance or used during appliance manufacture.

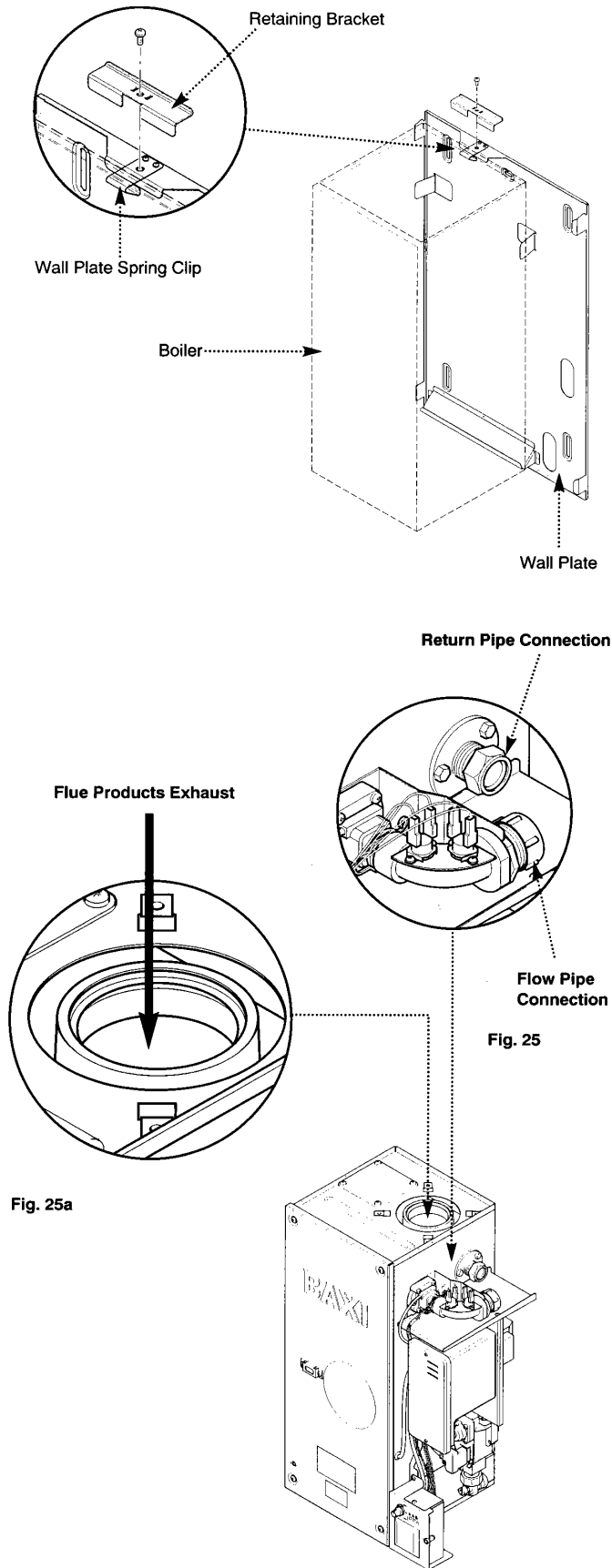

8.3 Fitting The Boiler (Fig. 24)

1. Remove the screw and retaining bracket from the wall plate spring clip.
2. Offer up the boiler to the wall plate and locate the rear bottom edge onto the self locating support at the base of the wall plate.
3. Rotate the boiler and engage into temporary spring retaining latch.
4. **Ensure the boiler is secured with the retaining bracket and screw previously removed, immediately.**
5. Remove thread protection caps from the FLOW and RETURN connections.

8.4 Making the Water Connections (Fig. 25)

1. The boiler has two side water connections, the front connection being FLOW and the rear connection being RETURN.
2. It is essential that Flow and Return pipes are connected to the correct fittings. The flow connection incorporates the boiler thermostats and a flow switch. To avoid damage to the flow switch when tightening the flow connection the use of two spanners is recommended.
3. A copper elbow, compression nut and olive are provided in the kit for the return connection.

NOTE: Drain cocks should be fitted to all system's low points and vents to all high points.

4. Ensure that any pipework is routed so as to leave the boiler via the spaces at the rear of the outer case, either at the top or at the bottom.

Pipework within the confines of the outercase should consist of solder fittings.

NOTE: It is important that the pipework does not interfere with the correct fitting of the outer case and a space of 14 mm clearance must be left between any vertical pipes and the outer edge of the wall plate.

8.5 Making the Condensate Drain Connection

1. Connect the condensate drain using the 1 "BSP nut and seal supplied. (see section 7.8.).

NOTE: To ensure the correct operation and integrity of the condensate drainage system

- Carefully pour approximately 1 cupful (250ml) of water into the flue products exhaust, at the top of the heat exchanger (Fig. 25a) to ensure a seal is made in the trap.

Fig. 26

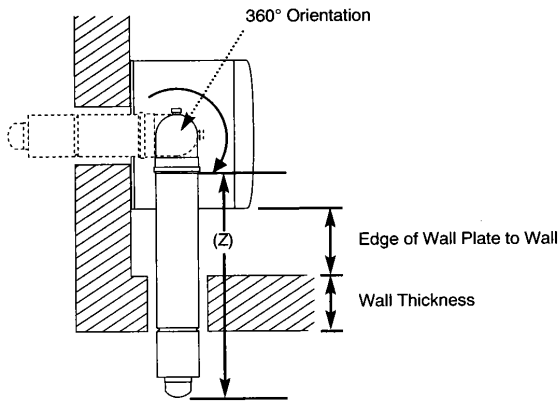
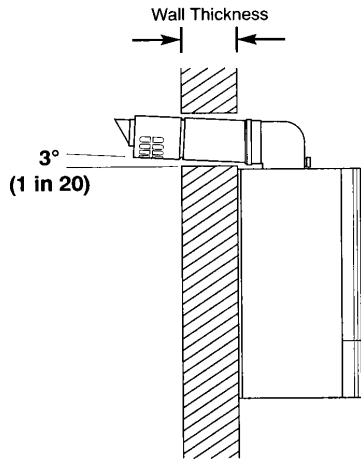

Fig. 27

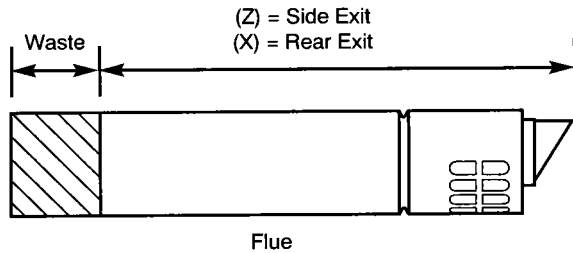
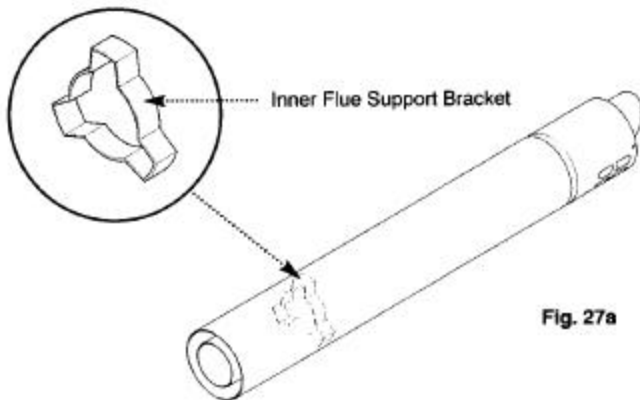

Fig. 27a



8.6 Making the Gas Connection

1. Connect the gas supply to the RC½ (½in BSPT internal) gas tap located on the lower right side of the boiler.

8.7 Fitting The Flue

Before fitting the flue, check the condensate drain integrity (see section 8.5).

IMPORTANT: The flue should always be installed with a 3° (1 in 20) fall from terminal to elbow, to allow condensate to run back to the boiler.

HORIZONTAL FLUE

1. The standard flue is suitable for lengths 270mm minimum to 800mm maximum (measured from the edge of the flue elbow outlet).

Rear Flue: maximum wall thickness - 630mm
Side Flue: maximum wall thickness - 565mm (left or right)

2. **For rear exit** - measure the wall thickness (Fig. 26) and to this dimension add 235mm. This dimension to be known as (X).
i.e. (X) = wall thickness + 235
3. Take the flue and mark off (X) from the terminal end as indicated in the diagram (Fig. 27).

Check your dimensions.

The flue tubes are fixed together. Cut through both tubes whilst resting the flue on the semicircular packing pieces. Deburr both tube ends.

4. **For side exit** - measure the distance from the edge of the wall plate to the inner face of the wall (Fig. 26) and to this dimension add the wall thickness + 275mm. This dimension to be known as (Z).
i.e. (Z) = wall plate to wall + wall thickness + 275
5. Take the flue and mark off (Z) from the terminal end as indicated (Fig. 27).

Check your dimensions.

The flue tubes are fixed together. Cut through both tubes whilst resting the flue on the semicircular packing pieces. Deburr both tube ends.

IMPORTANT: Check all measurements before cutting

NOTE: When cutting ensure the cut does not interfere with the inner flue support bracket (Fig. 27a).

Fig 28

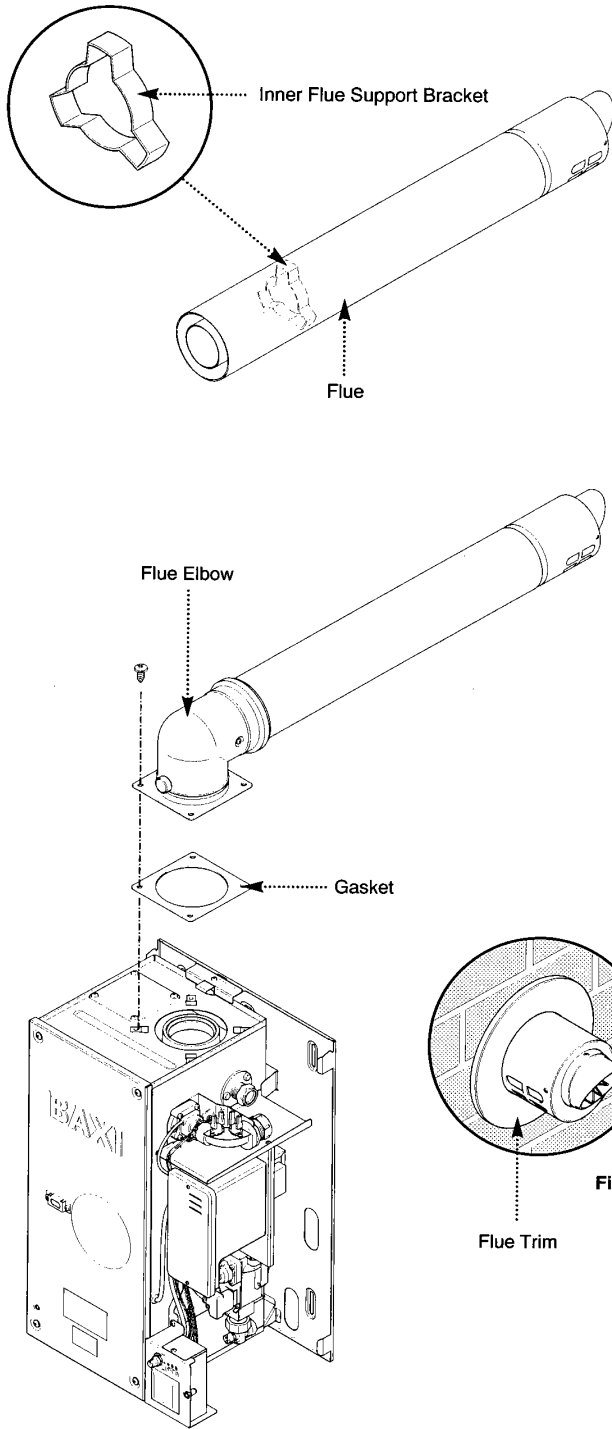

Fig. 29

8.7 Fitting the Flue (Cont)

6. Ensure the inner flue support bracket is positioned in the flue (Fig. 28).
7. Engage the flue into the flue elbow using soap solution to ease the engagement ensuring the flue is assembled as shown (Fig. 29).
8. Place the gasket over the flue exit on the boiler.
9. Slide the flue assembly through the hole in the wall.
10. Engage the elbow on to the flue connection on top of the boiler. Secure with the four screws supplied in the kit.
11. Make good between the wall and air duct outside the building ensuring the 3° drop between the terminal and elbow.
12. The flue trim should be fitted once the installation is complete and the flue secure (Fig. 30). Apply a suitable mastic to the inside of the trim and press against the wall finish, making sure the brickwork is dust free and dry.
13. If necessary fit a terminal guard (see Section 7.11).

VERTICAL FLUEING

1. Only a flue approved with the Baxi Barcelona can be used.
2. For information on vertical flues consult the Baxi Gas Central Heating Boilers Installer Guide or Notes for Guidance supplied with the vertical flue pack.

8.8 Making The Electrical Connections

WARNING: This appliance must be earthed

1. The electrical connections are on the right hand side of the unit inside the electrical box.
2. Undo the two screws securing the electrical box cover and remove the cover (Fig. 31).
3. Undo the two screws securing the SL, ⊕, N, PF cable clamp and place to one side (Fig. 32).
4. If fitting an integral programmer kit please refer to kit instructions at this stage.
5. If necessary the output of the boiler can be increased to 100,000 Btu/h.
 - a) Draw the control PCB forwards out of the electrical box (the control PCB is the right hand board).
 - b) Pull off the two jumper connections at the top rear corner of the PCB (Fig. 32a).
 - c) Replace the PCB and continue with the installation.
6. Route the incoming electrical cable/s through the grommet in the support bracket. This will prevent damage to the cable (Fig. 31a).
7. Lay the cable through the cable clamp to gauge the length of cable required when it is connected to the 4-way terminal block (Fig. 32).
8. Connect the (S/L), (N) and (⊕) wires to the 4-way terminal block and refit the cable clamp (Fig. 33).
9. The pump can be wired directly to the system controls or to the P/F connector on the boiler. For full TRV installation refer to section 6.1.
10. The P/F connection should only be used on a full TRV system without a bypass.
11. Check the electrical installation for; earth continuity, short circuits, resistance to earth, correct polarity and fuse failure.
12. Replace the electrical box cover and secure.

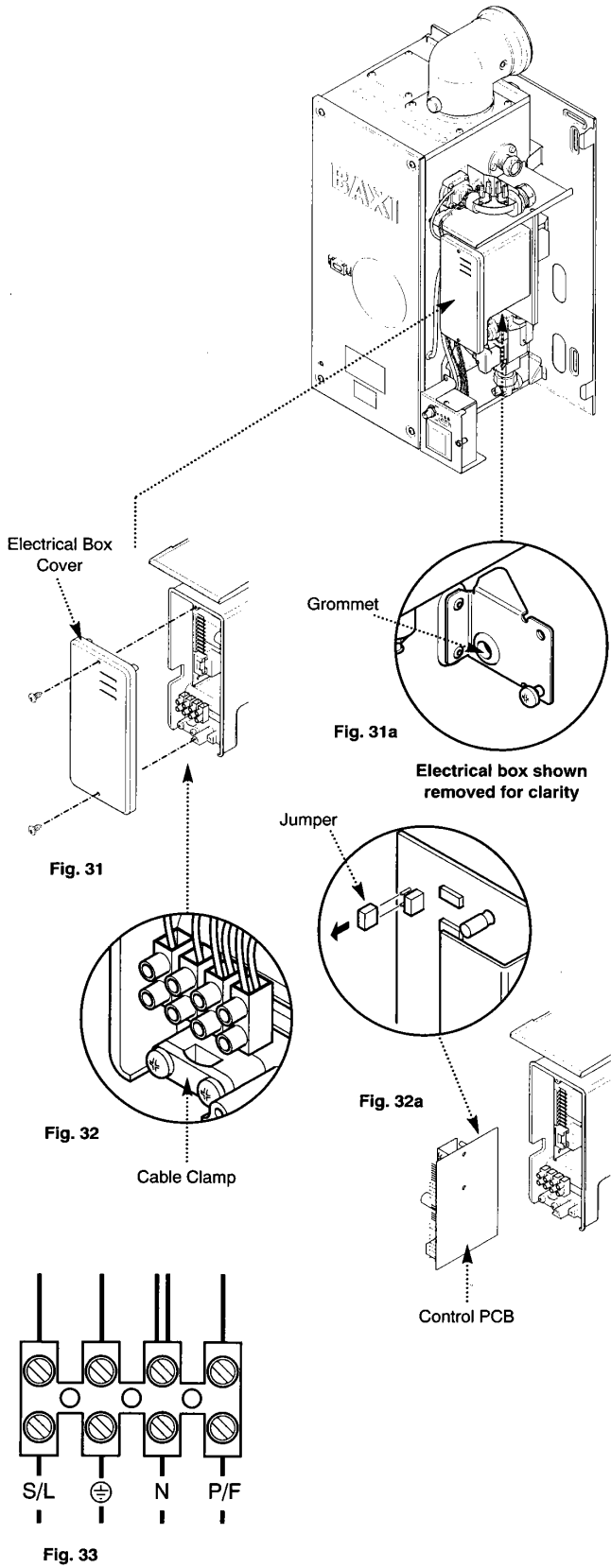

9.0 Electrical – page 22

9.1 Schematic Wiring Diagram

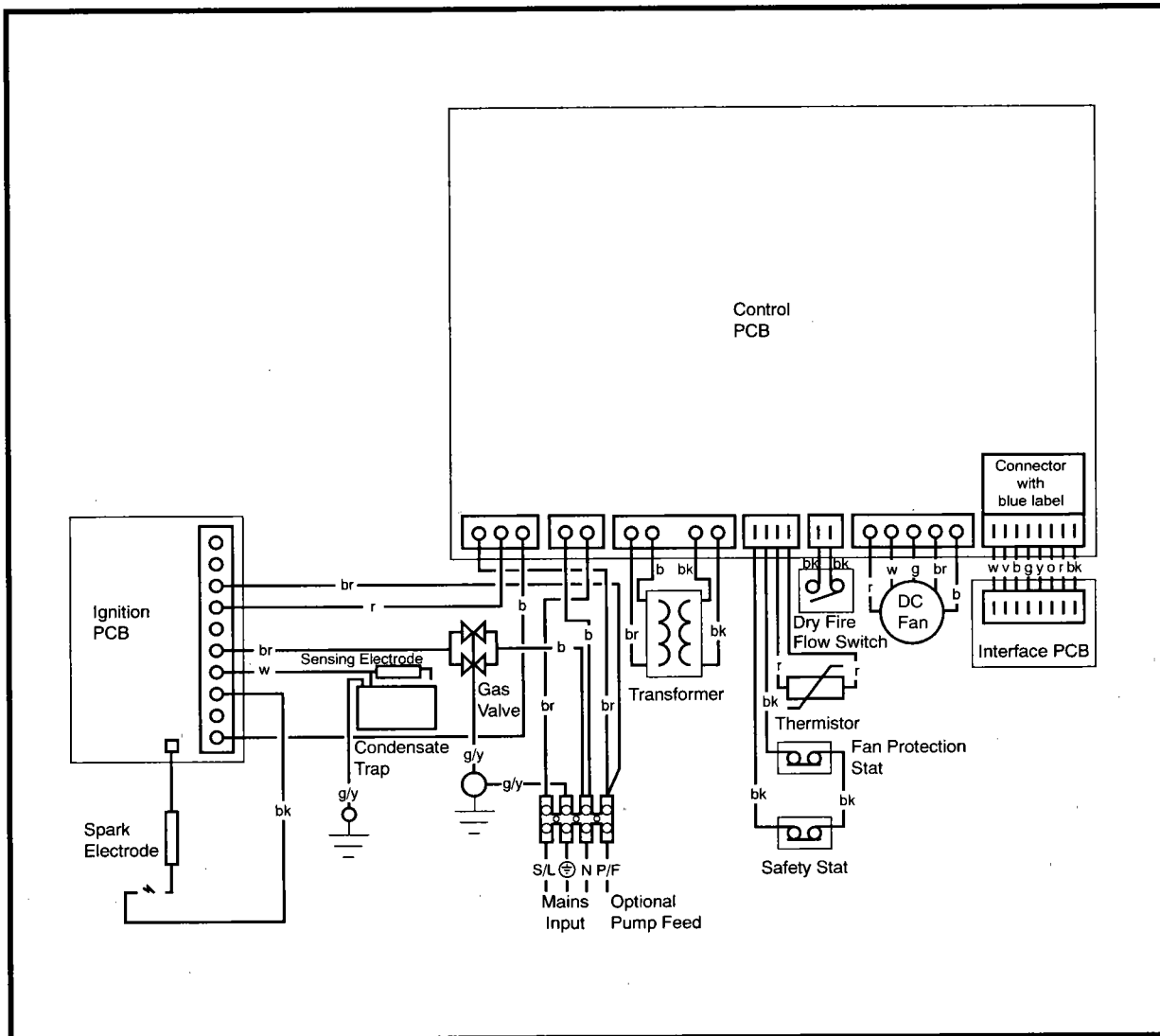

Key To Wiring Colours

| | |
|------------|--------------------|
| b - Blue | r - Red |
| bk - Black | g - Green |
| w - White | g/y - Green/Yellow |
| br - Brown | y - Yellow |
| v - Violet | o - Orange |

9.2 Illustrated Wiring Diagram

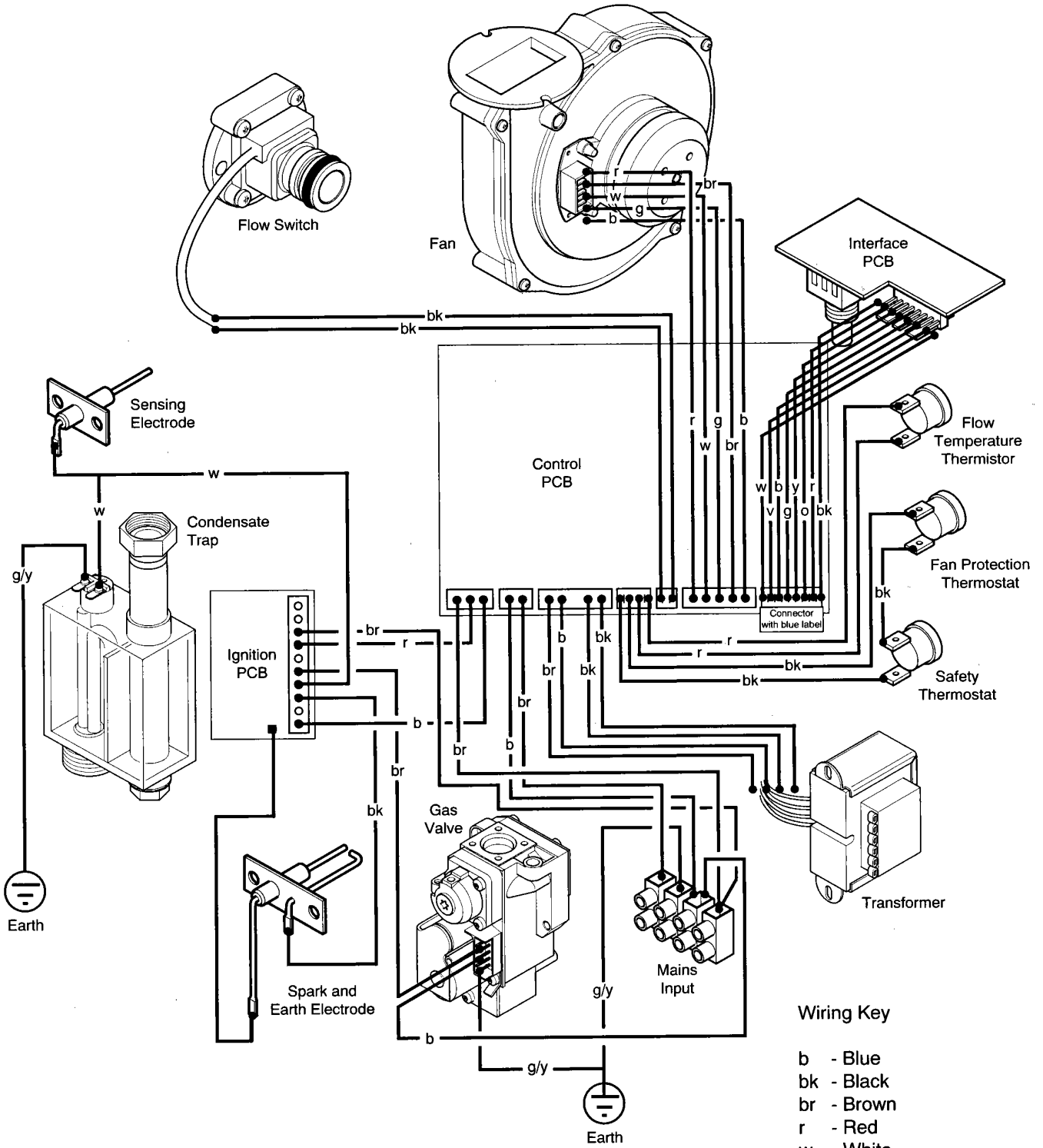

10.1 Commissioning the Boiler

1. Reference should be made to BS 5449 Section 5 when commissioning the boiler.
2. Flush the whole system using a suitable flushing agent (see Section 6.2) and vent the radiators. Check for water leaks.
3. Refill the system with inhibitor following the inhibitor manufacturer's instructions and BS 7593 Code of Practice for Treatment of Water in Domestic Hot Water Central Heating Systems (see Section 6.2).
4. Turn the gas supply on and purge the system according to BS 6891.
5. Turn the gas service cock anticlockwise to the ON position and check for gas soundness up to the gas valve (Fig. 34).
6. Turn the boiler control knob fully clockwise to 'HIGH' (Fig. 35) and run the system and check the boiler for correct operation.

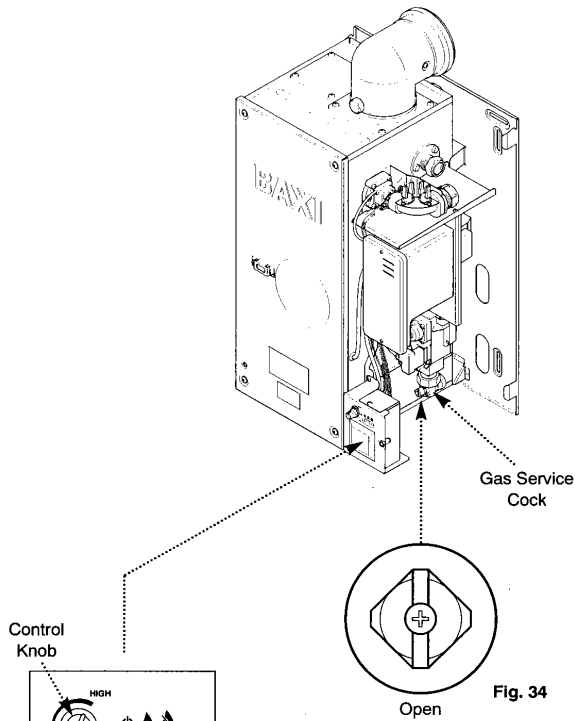

Fig. 35

Fig. 34

NOTE: The boiler is self-regulating and the gas rate will modulate between inputs of 33.76kW and 10.2kW dependent upon the system load. The input is factory set at 23.45kW and can be altered to 33.76kW - see section 8.8.
No adjustment of the gas valve is permissible.

7. With the system cold and all controls calling for heat check the gas pressure at the inlet tapping of the gas valve (Fig. 36). The pressure must be a minimum of 18.1 mbar.

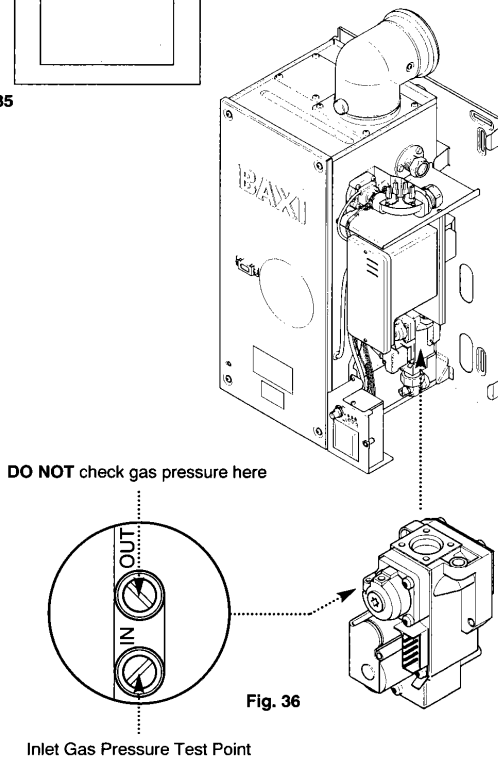
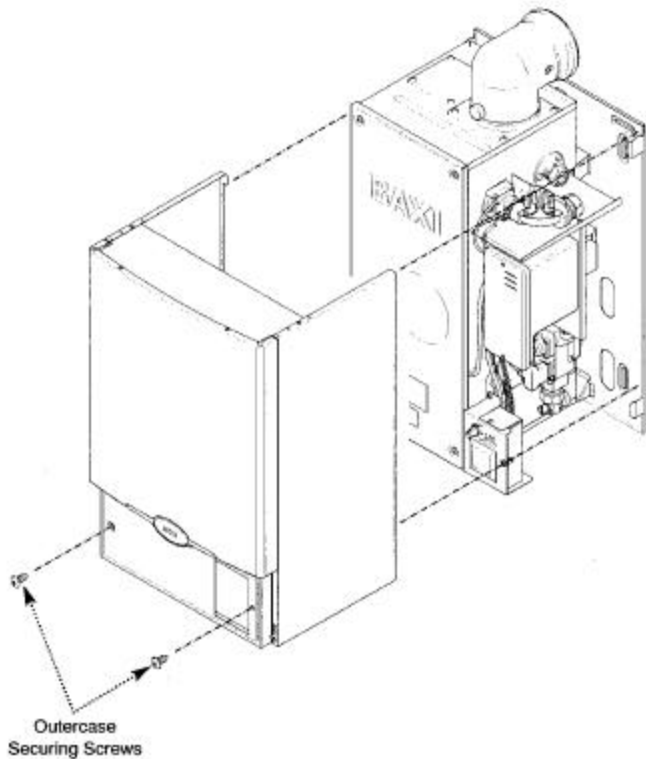

Fig. 36

Inlet Gas Pressure Test Point

11.0 Fitting the Outer Case – page 25

Fig. 37



11.1 Fitting The Outer Case

1. Position the outercase over the boiler engaging the lugs in the side flanges over the hooks on the wall plate (Fig. 37).
2. Using the two screws supplied in the kit, secure the outercase to the combustion box (Fig. 37).
3. Replace the lower front door panel (Fig. 38).
4. Carefully read and complete all sections of the “Benchmark” Installation, Commissioning and Service Record Log Book that are relevant to the appliance and installation. The details of the Log Book will be required in the event of any warranty work. The Log Book must be handed to the user for safe keeping and each subsequent regular service visit recorded.
5. Instruct the user in the operation of the boiler controls. Hand over the User’s Operating, Installation and Servicing Instructions and the Log Book, giving advice on the necessity of regular servicing.
6. Advise the user that a plume of vapour from the flue terminal is normal, and that there is no need for concern.

Fig. 38

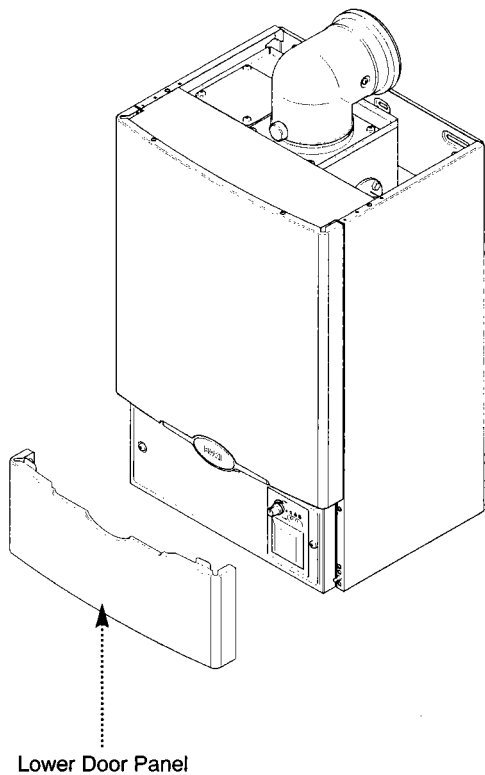

IMPORTANT: This boiler is fitted with an aluminium alloy heat exchanger. It is important that the system is thoroughly flushed in accordance with BS 7593 and that one of the following inhibitors is used:

BETZ DEARBORN SENTINEL X100

FERNOX COPAL

Refer to inhibitor manufacturer’s instructions for correct use. Failure to comply with this requirement will invalidate the appliance warranty.

It is also important to check the inhibitor concentration after installation, system modification and at every service.

Date Boiler Installed/...../.....

Inhibitor Used

7. This label is located on the electrical box front cover on the boiler. Detail of system treatment should be added for future reference.

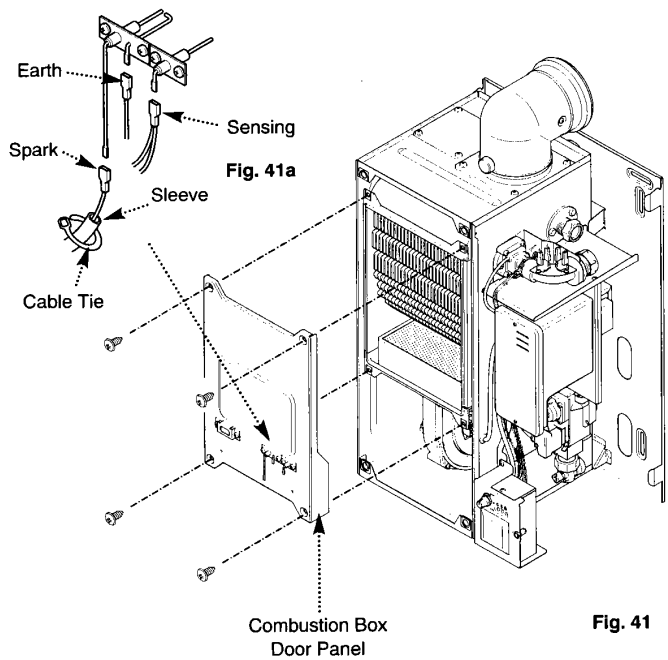
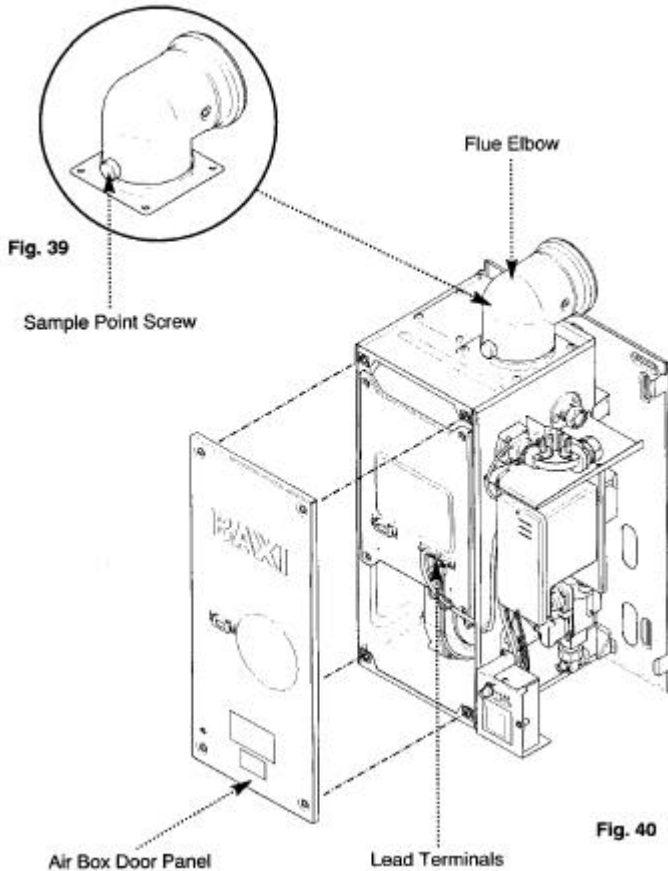

12.1 Annual Servicing

IMPORTANT: When servicing ensure that both the gas and electrical supplies to the boiler are isolated before any work is started.
 When the boiler control knob is switched off the control PCB remains live. Therefore it is important to isolate the electrical supply.
 Hazardous materials are not used in the construction of Baxi products, however reasonable care during service is recommended.
 When replacing the combustion box door after servicing it is essential that the retaining screws are tightened fully.

1. For reasons of safety and economy, it is recommended that the boiler is serviced annually. Before servicing please read Section 1.2 Important Information.
2. After servicing, complete the relevant section of the “Benchmark” Installation, Commissioning and Service Record Log Book. This should be in the possession of the user.
3. If it is intended to undertake a flue gas analysis as part of the service, then whilst the boiler is running measure the CO and CO₂ content of the flue products, by removing the sample point screw on the flue elbow (Fig. 39) and inserting a suitable sampling probe. If the CO/CO₂ ratio is greater than 0.02 then a more extensive service and investigation will be required. If the CO/CO₂ ratio is less than 0.02 proceed as follows:
4. Ensure that the boiler is cool.
5. **Ensure that both the gas and electrical supplies to the boiler are isolated.**
6. Remove the outercase and lower door panel (see Fitting the Outercase, Section 11.0).
7. Release the four ¼ turn screws securing the air box door panel and remove the door (Fig. 40).
8. Disconnect the leads from the centre and right hand terminals (earth and flame sensing probe). The spark electrode lead is permanently fixed to the electrode. Undo the re-usable cable tie and pull down the sleeving to expose the joint in the electrode lead. Disconnect the lead (Fig. 41a).
9. Undo the four screws securing the combustion box door and remove the door (Fig. 41).
10. Visually check for debris/damage and clean or replace if necessary the following:
 - a) Burner (**Fragile - handle with care**).
 - b) Heat exchanger fins.
 - c) Fan compartment (check also for condensate leaks)
 - d) Insulation
 - e) Door seals-**Important:** Pay particular attention to the condition of the combustion box door seals.
 - f) Electrodes
 - g) Check condensate trap for debris. **NOTE:** If necessary remove the trap drain plug and place a vessel underneath to catch the condensate (care should be taken as this could be hot). Clean the trap and refit the drain plug.
 - h) Top of heat exchanger

12.1 Annual Servicing (Cont)

NOTE: General cleaning can be undertaken using a vacuum. However debris should only be gently blown off the burner skin due to its fragile nature.

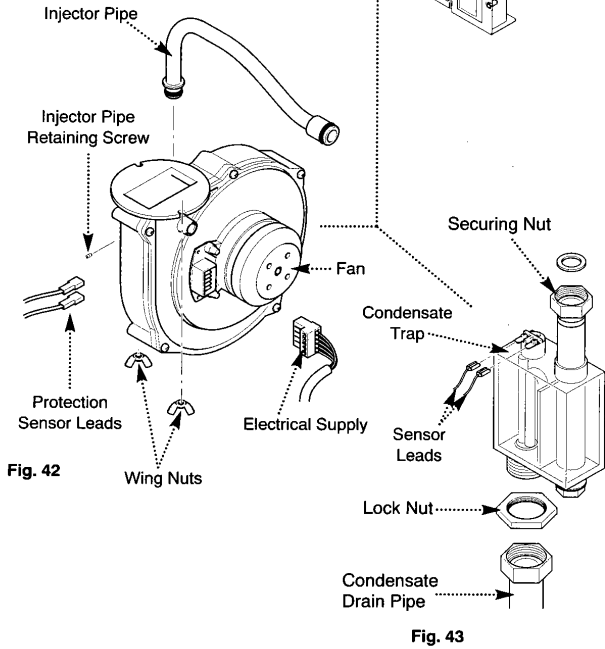
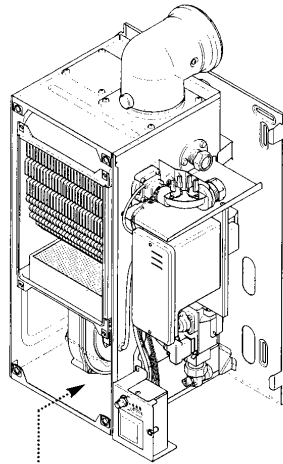
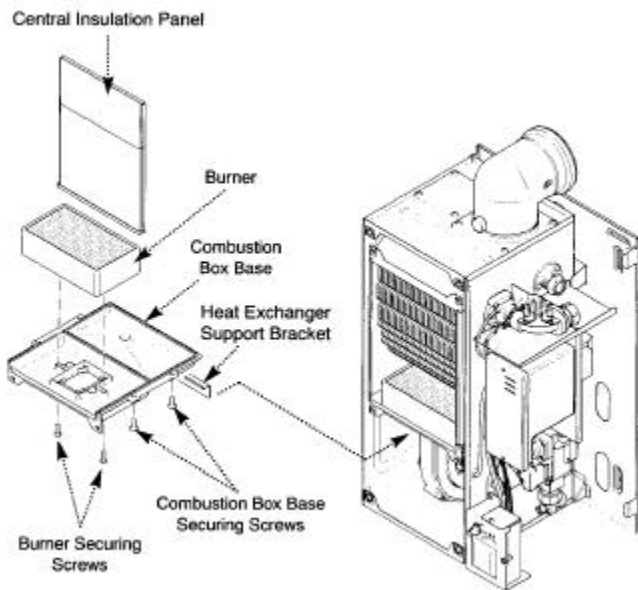

Fig. 42

Fig. 43

Fig 44



11. If CO/CO₂ ratio is greater than 0.02 then proceed as follows to allow removal and cleaning of inner and rear heat exchanger flueways:
 - a) Disconnect the electrical leads to the fan component protection sensor (Fig. 42).
 - b) Loosen the screw retaining the gas injector pipe at the venturi (Fig. 42).
 - c) Undo the two wing nuts to disconnect the fan (Fig. 42).
 - d) Remove the fan and disconnect the electrical supply to it (Fig. 42).
 - e) Remove the gas injector pipe from the gas valve (push-fit) (Fig. 42).
 - f) Undo the condensate trap securing nut, lock nut and the condensate drain pipe. Remove the condensate trap and disconnect the sensor leads (Fig. 43).
 - g) Remove the two screws securing the burner and remove the burner. Visually inspect the internal burner baffle for obstruction.

NOTE: The burner skin is fragile - handle with care. Clean and if necessary replace the burner (Fig. 44) (see note above).

- h) Loosen the two screws retaining the heat exchanger support bracket and slide to the left to remove (Fig. 44).
 - i) Remove the four screws securing the heat exchanger/combustion box base and withdraw the base.
 - j) Lower the central insulation panel and check condition (Fig. 44). Replace the lower insulation pad if necessary.
 - k) Ensure the heat exchanger fins are clear of any obstruction.
 - l) Check condition of all seals. **Important:** Pay particular attention to the condition of the combustion box door seals.
 - m) Reassemble in reverse order.
12. Complete the relevant section of the "Benchmark" Installation, Commissioning and Service Record Log Book and hand it back to the user.

Fig. 45

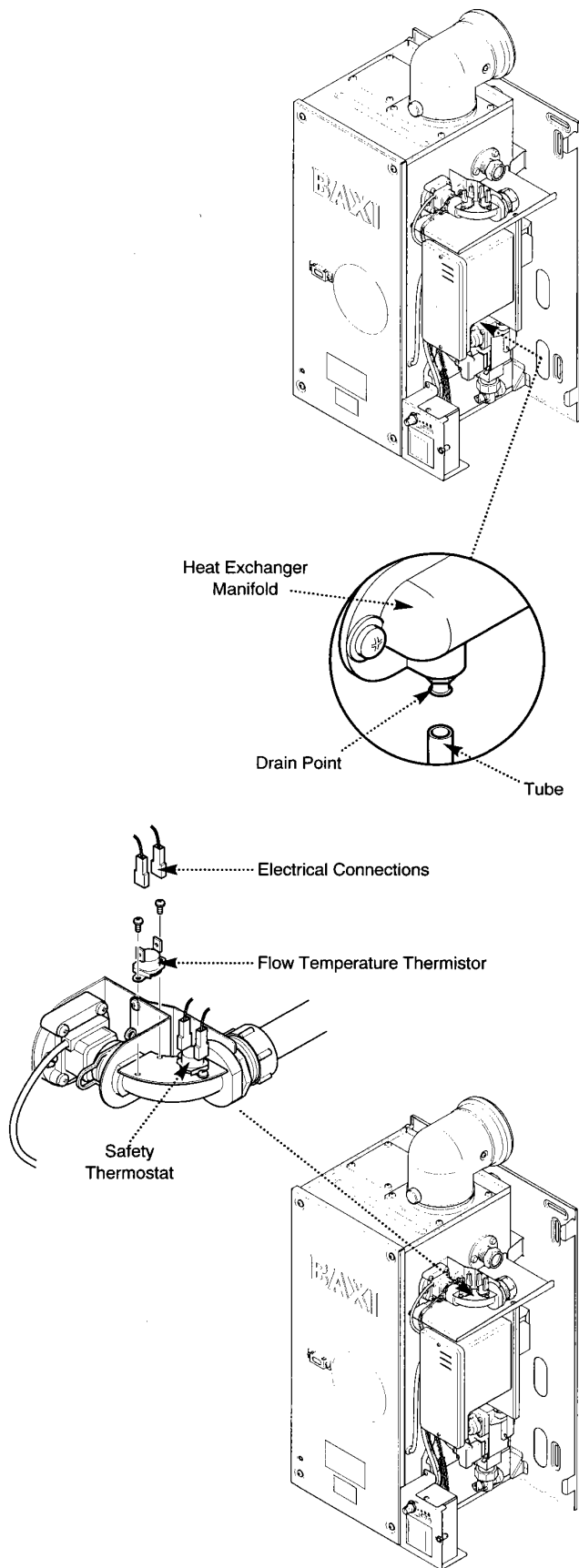

Fig 46

13.1 Changing Components

IMPORTANT: When changing components ensure that both the gas and electrical supplies to the boiler are isolated before any work is started. When the boiler control knob is switched off the control PCB remains live. Therefore it is important to isolate the electrical supply. Hazardous materials are not used in the construction of Baxi products, however reasonable care during service is recommended. When replacing the combustion box door after changing components, it is essential that the retaining screws are tightened fully.

1. Before changing any components please read Section 1.2 Important Information.
2. Remove the outer case and lower door panel (see "Fitting the Outercase" Section 11.0).
3. Isolate the water circuit and drain the system as necessary. A drain point is located on the heat exchanger manifold at the right hand side of the boiler (Fig. 45) to enable the heat exchanger to be drained.
4. Place a tube on the drain point to drain water away from electrics. Turn anticlockwise to open (Fig. 45).

NOTE: When reassembling always fit new 'O' rings, ensuring their correct location on the spigot. Green "O" rings are used for gas joints and Black "O" rings for water joints. Use Greasil 4000 (Approved Silicone Grease).

5. After changing a component re-commission the boiler where appropriate and check the inhibitor concentration (see Section 6.2 and 10.1).

The thermistor, safety thermostat, interface PCB and the flow switch can be accessed after removal of the outer case.

13.2 Flow Temperature Thermistor and Safety Thermostat (Fig. 46).

1. The procedure is the same for both the thermistor and the safety thermostat.
2. Remove the electrical connections from the sensor.
3. Unscrew the sensor from the pipe.
4. Fit the new thermistor or safety thermostat and reassemble in reverse order.

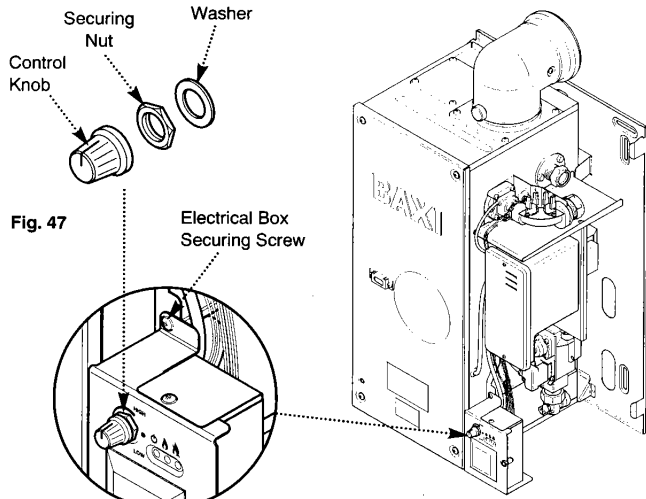

Fig. 47

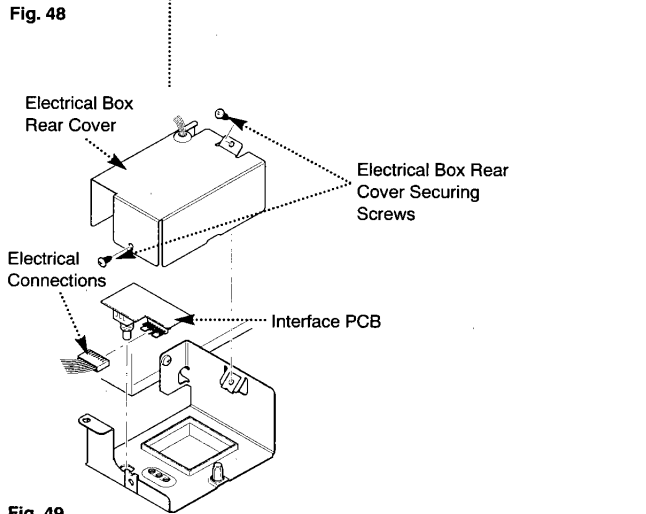
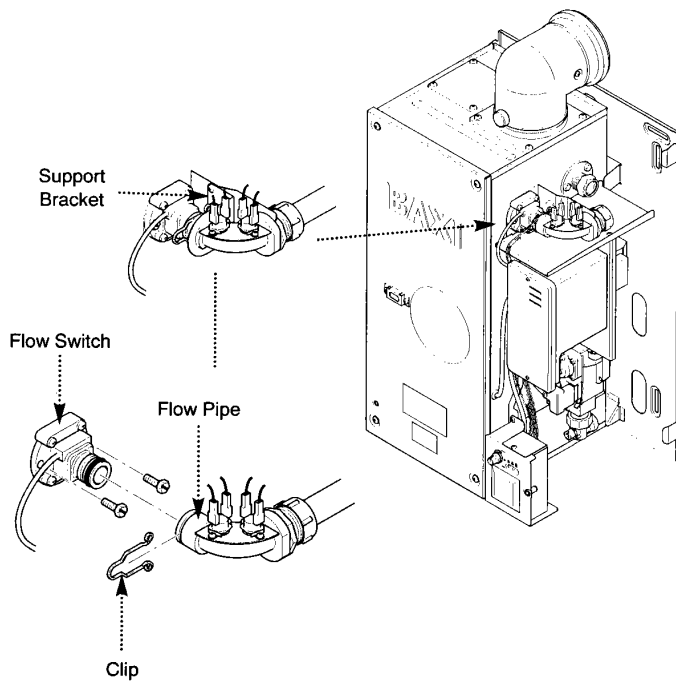

Fig. 48

Fig. 49

Fig. 50



13.3 Interface PCB

1. Pull the control knob off the spindle and remove the securing nut and washer (Fig. 47).
2. Release the electrical box securing screw and hinge the electrical box down (Fig. 48).
3. Remove the two rear cover securing screws and remove the rear cover (Fig. 49).
4. Lift the PCB from the electrical box and remove the electrical connections (Fig. 49).
5. Fit the new PCB and reassemble in reverse order.

13.4 Flowswitch (Fig. 50)

1. Drain the boiler (see Section 13.1 paragraph 2 & 3).
2. Disconnect pipework, loosen elbow locking nut and undo screws on support bracket.
3. Remove the clip securing the flow pipe to the flowswitch.
4. Remove the two screws securing the flow switch to the boiler.
5. Disconnect the inline electrical connection.
6. Remove the flowswitch.
7. Fit the new flowswitch and reassemble in reverse order.
8. Recommission the boiler and check the inhibitor concentration (see Section 6.2 and 10.1).

The control and ignition boards can be accessed on the removal of the main electrical box cover.

1. Remove the two screws securing the main electrical box cover (Fig. 51).

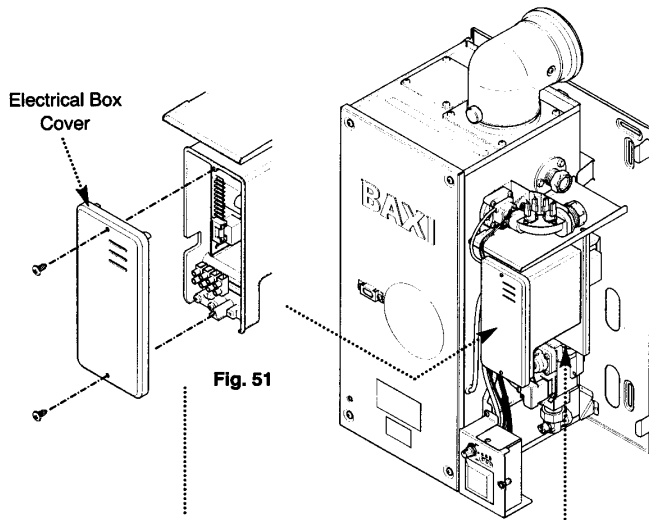

13.5 Control Board (Fig. 52)

1. Slide out the control board (right hand side) and disconnect the electrical connections noting their positions.
2. Check if the two jumper connections have been removed from the board (see section 8.8), if so remove the jumpers from the new control board.
2. Fit the new control board and reassemble in reverse order.

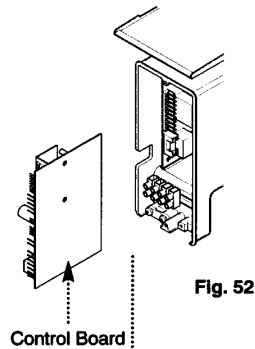

13.6 Ignition Board (Fig. 53)

1. Remove the control board, (13.5) and slide out the ignition board (left hand side) and disconnect the electrical connections noting their positions.
2. Fit the new ignition board and reassemble in reverse order.

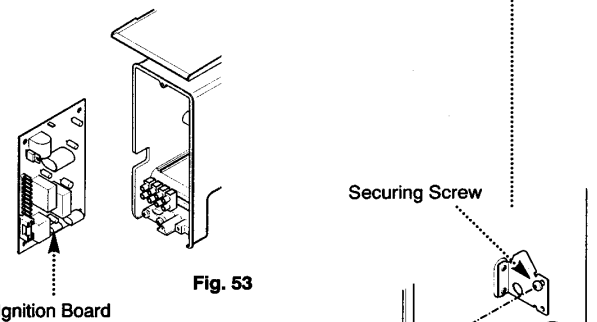

13.7 Transformer (Fig. 54)

1. After the removal of the control and ignition boards the transformer can be accessed. Loosen the two electrical box mounting plate securing screws, remove the front drip tray securing screw and lift the assembly to clear the keyhole slots.
2. The transformer is mounted on the rear of the electrical box mounting plate.
3. Remove the two transformer mounting screws and remove the transformer.
4. Fit the new transformer and reassemble in reverse order.

NOTE: Check the original board for the presence of input jumpers - see section 8.8. Set the new board as the original.

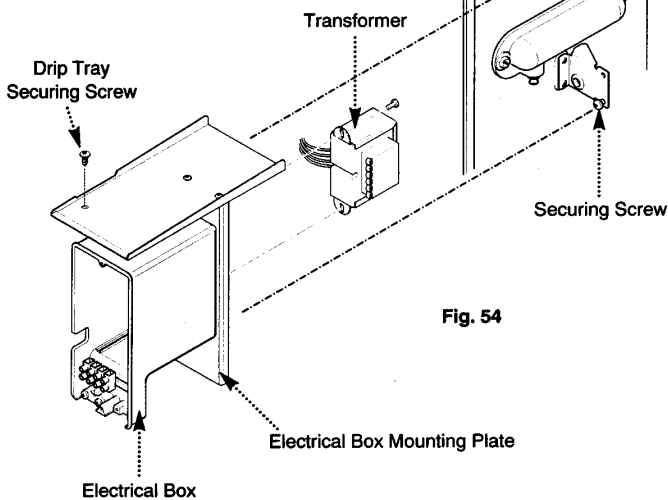

The fan and venturi, gas valve, injector pipe, condensate trap, fan protection sensor, spark and sensing electrodes can be accessed and changed on the removal of the airbox door panel.

1. Remove the airbox door panel by loosening the four ¼. turn screws (Fig. 55).

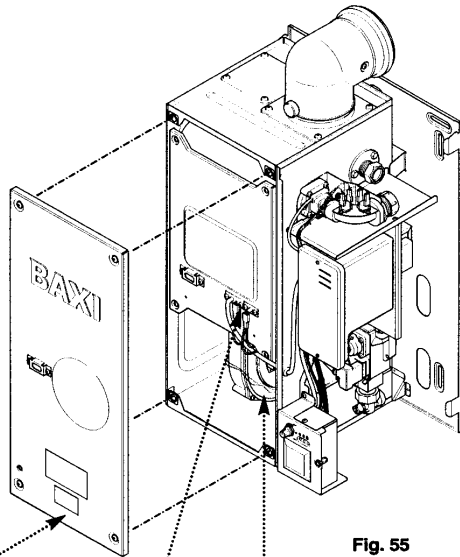

Fig. 55

Air Box Door Panel

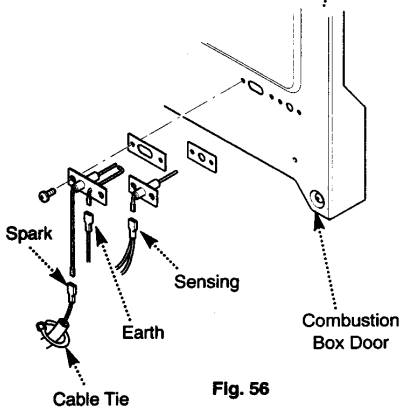

Fig. 56

Cable Tie

Injector Pipe

Screw

Injector Opening

Protection Sensor

Venturi

Fan

Electrical Connections

Fig. 57

Wing Nuts

Electrical Connection

13.8 Spark and Sensing Electrodes (Fig. 56)

1. Disconnect the leads from the centre and right hand terminals (earth and flame sensing probe). The spark electrode lead is permanently fixed to the electrode. Undo the re-usable cable tie and pull down the sleeving to expose the joint in the electrode lead. Disconnect the lead.

| | | |
|---------|---|--------------|
| Spark | - | Opaque cable |
| Earth | - | Black cable |
| Sensing | - | White cable |

2. Remove the two screws securing each of the electrodes to the combustion box door and remove the electrodes.
3. Fit the new electrodes and reassemble in reverse order.

NOTE: The spark electrode sleeve should always cover the joint in the electrode lead to prevent tracking.

13.9 Fan (Fig. 57)

1. Loosen the screw holding the injector pipe into the venturi.
2. Remove the electrical connections to the fan protection sensor on the fan.
3. Remove the wing nuts securing the fan to the base of the combustion box.
4. Lower the fan and remove.
5. Disconnect the electrical supply from the right hand rear of the fan.
6. If changing the fan remove the screws securing the venturi and fan protection sensor bracket, noting the positions of the injector opening and sensor bracket, fix them to the new fan.
7. Fit the new fan and reassemble in reverse order.

The injector pipe, condensate trap and gas valve can be changed after the removal of the fan.

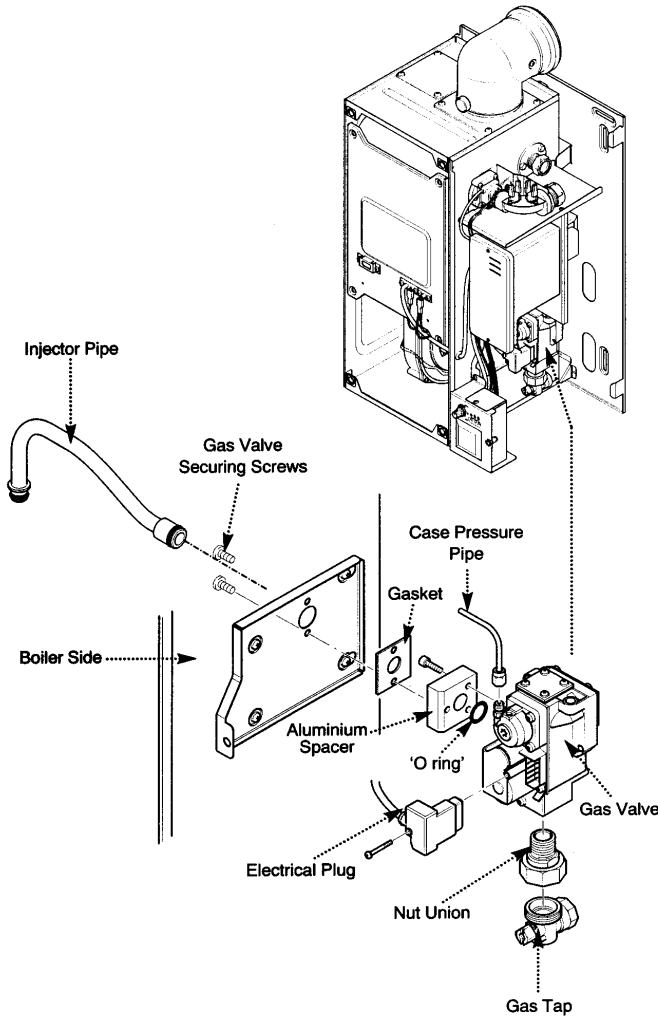
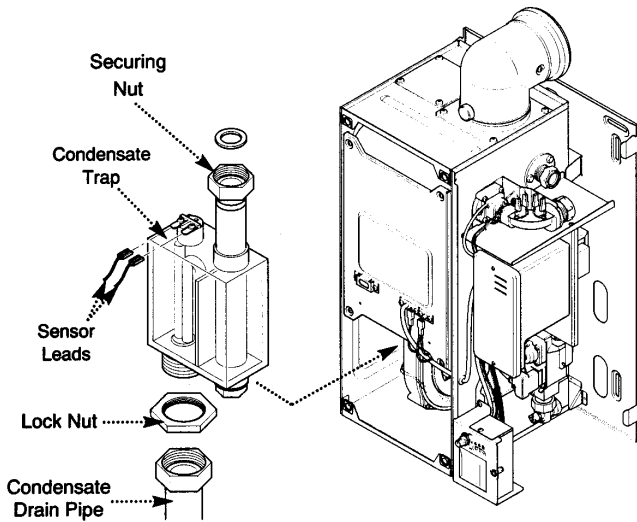

Fig. 59



The removal of the fan is necessary to enable the changing of the injector pipe, condensate trap and gas valve (see section 13.9).

13.10 Injector Pipe (Fig. 58)

1. Remove the injector pipe by pulling out from the 'O' ring joint in the gas valve.
2. Fit the new injector pipe and reassemble in reverse order.

13.11 Gas Valve (Fig. 58)

1. Release user interface and pivot downward for better access.
2. Disconnect the gas inlet union at the gas tap.
3. Undo the case pressure pipe from the gas valve.
4. Undo the screw and disconnect the electrical plug from the gas valve.
5. Remove the two gas valve securing screws from inside the air box holding the gas valve.
6. Remove the gas valve from the airbox side.
7. Remove the nut union, aluminium spacer and its gasket from the gas valve.
8. Fit the nut union, aluminium spacer and its gasket to the new valve.
9. Fit the new gas valve and reassemble in reverse order.

13.12 Condensate Trap (Fig. 59)

1. Disconnect the condensate trap from the base of the heat exchanger.
2. Disconnect the condensate drain (outside the boiler) from the condensate trap.
3. Undo the condensate trap lock nut.
4. Remove the condensate trap from the boiler.
5. Disconnect the sensor leads.

Fit the new condensate trap and reassemble in reverse order.

The burner and heat exchanger can be changed after removal of the combustion box door. To change the heat exchanger, the fan and burner must be removed first (see section 13.9).

1. Remove the combustion box door by removing the four securing screws (Fig. 60).

IMPORTANT: On refitting the combustion box door check the condition of the combustion box door seals.

13.13 Burner (Fig 61)

WARNING: The burner skin is fragile: Handle with care

1. Remove the two screws securing the burner to the base of the combustion box.
2. Remove the burner carefully from the combustion box base.
3. Fit the new burner and reassemble in reverse order.

13.14 Heat Exchanger

1. Drain the boiler (see section 13.1 paragraph 2 & 3).
2. Remove all components in the base of the airbox.
3. Undo the screws on the support bracket. Remove the screws securing the flow switch and return connections and remove the connections (Fig. 64).
4. Remove the electrical connections from the P.C.B.s (see section 13.5 & 13.6).
5. Loosen the two screws securing the electrical box mounting plate and remove the assembly (Fig. 62).
6. Remove the screws securing the heat exchanger manifold and remove the manifold (Fig. 63).
7. Lift the heat exchanger assembly and rotate the bottom upwards whilst pulling it forwards out of the airbox.
8. Fit the new heat exchanger and reassemble in reverse order.
9. Recommission the boiler and check the inhibitor concentration (see Section 6.2 and 10.1).

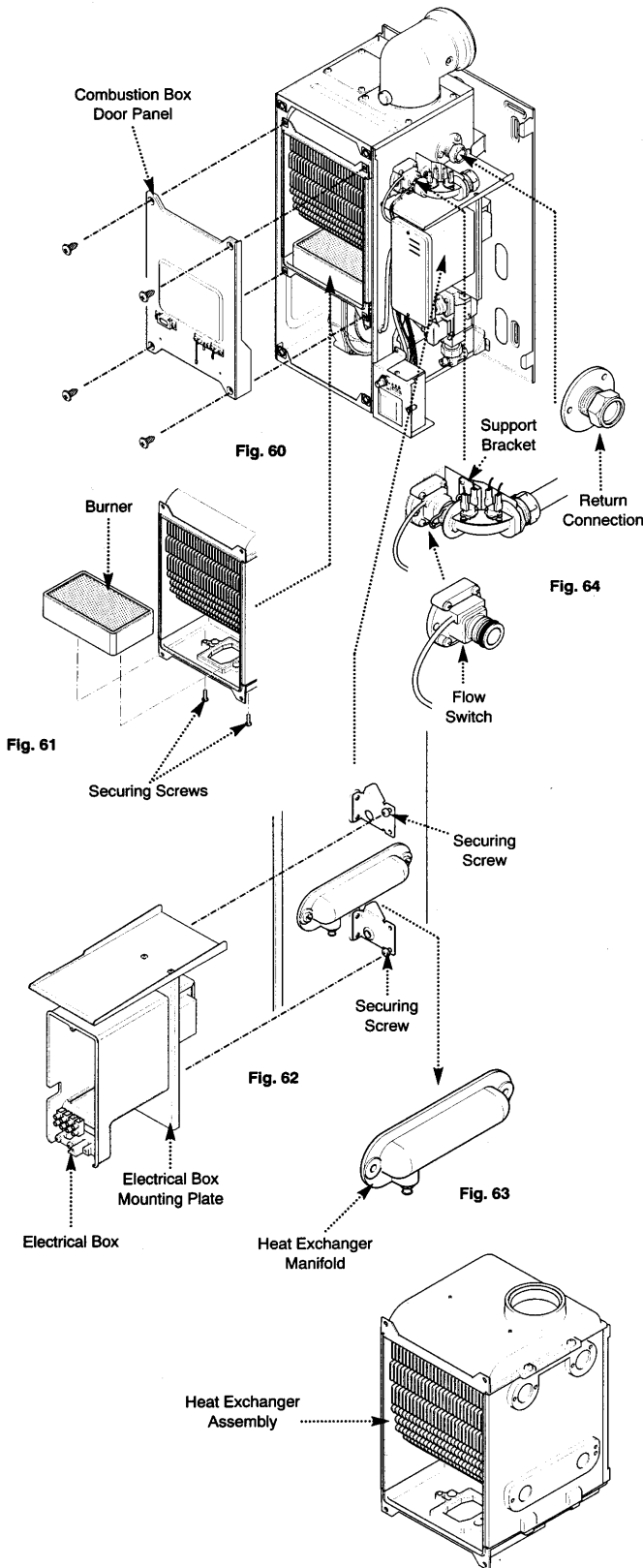
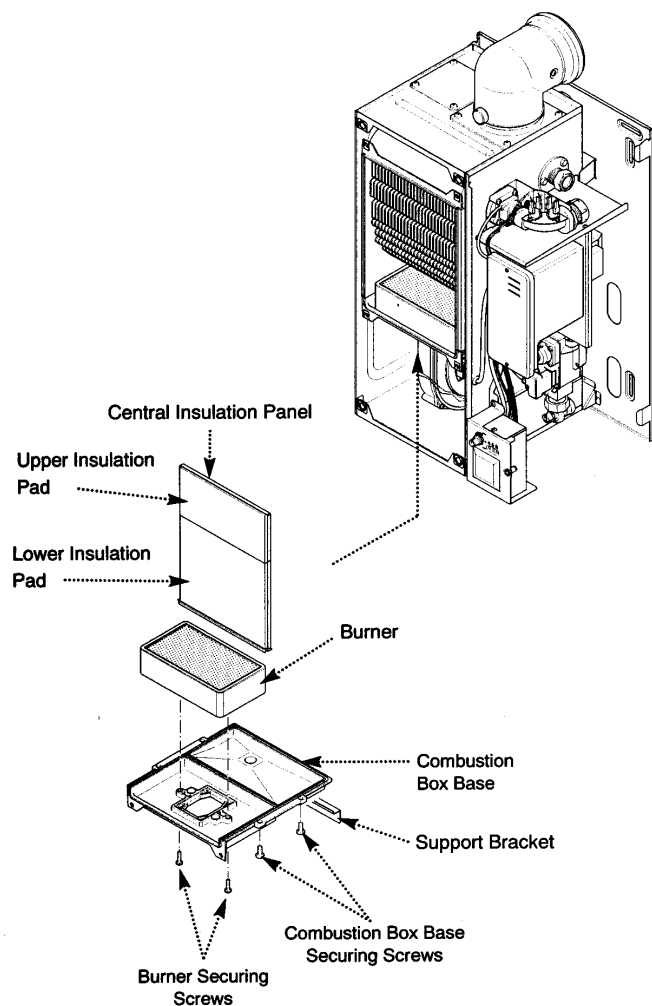

Fig. 65



13.15 Heat Exchanger Lower Insulation Pad (Fig. 65)

1. Remove all components in the base of the airbox.
2. Remove the burner (see section 13.13).
3. Remove the four bolts securing the combustion box base.
4. Remove the combustion box base.
5. Pull the central insulation panel down from the centre of the heat exchanger and remove the lower insulation pad.
6. Fit the new insulation pad and reassemble in reverse order.

13.16 Heat Exchanger Upper Insulation Pad

1. Remove all components in the base of the airbox.
 2. Remove the burner (see section 13.13).
 3. Remove the heat exchanger (see section 13.14).
 4. Remove the four bolts securing the combustion box base.
 5. Remove the combustion box base.
 6. Pull the central insulation panel down from the centre of the heat exchanger.
 7. Fit the new insulation pad and reassemble in reverse order.
-

14.0 Short Parts List – page 33

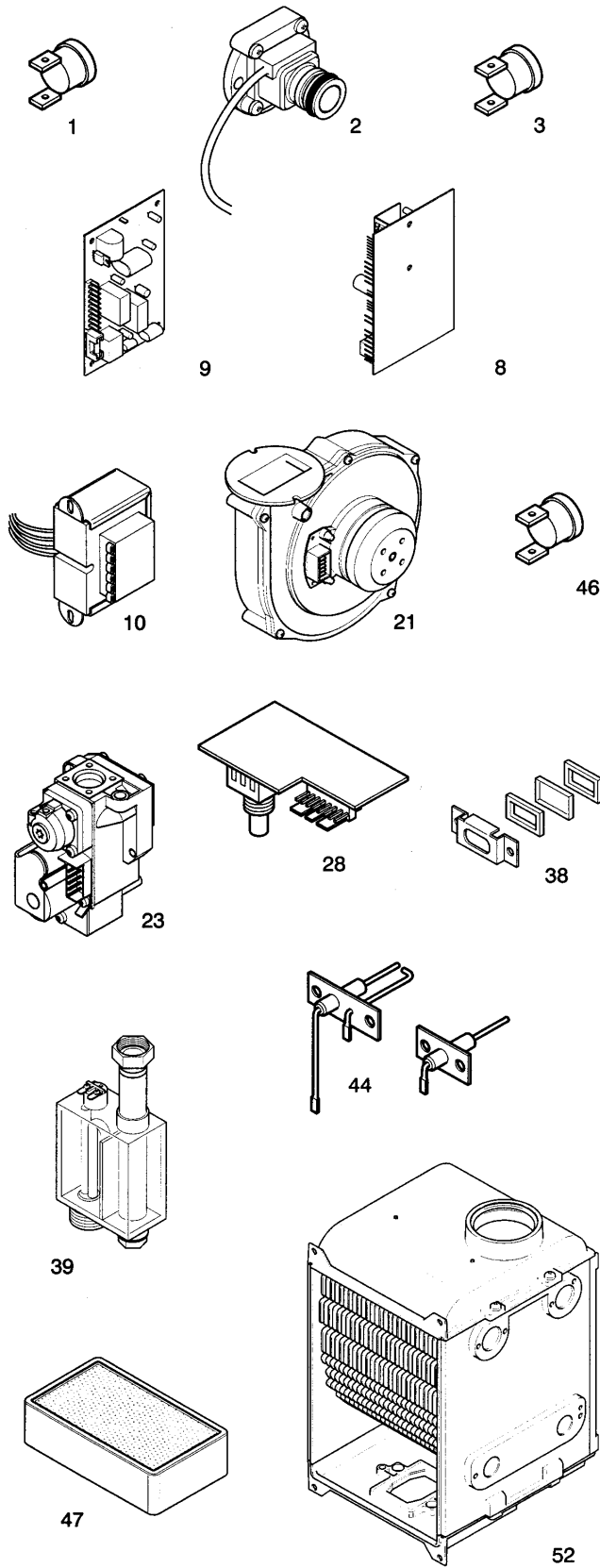

Short Parts List

| Key No. | G.C. No. | Description | Manufacturers Part No. |
|---------|----------|-----------------------------------|------------------------|
| 1 | E06 058 | Flow Temperature Thermistor (Red) | 242458 |
| 2 | E06 059 | Flow Switch | 242459 |
| 3 | E06 060 | Safety Thermostat (Black) | 242460 |
| 8 | E06 064 | Control PCB | 242463 |
| 9 | E06 065 | Ignition PCB | 242464 |
| 10 | E06 066 | Transformer | 242465 |
| 21 | E06 074 | Fan | 242472 |
| 23 | E06 075 | Gas valve | 242473 |
| 28 | E06 079 | Interface PCB | 242477 |
| 38 | E06 085 | Viewing window | 242464 |
| 39 | E06 086 | Condensate Trap | 242485 |
| 44 | E06 091 | Electrodes Kit | 242490 |
| 46 | E06 092 | Fan Protection Thermostat | 242491 |
| 47 | E06 093 | Burner Assy | 242492 |
| 52 | E06 097 | Heat Exchanger Assy | 242497 |

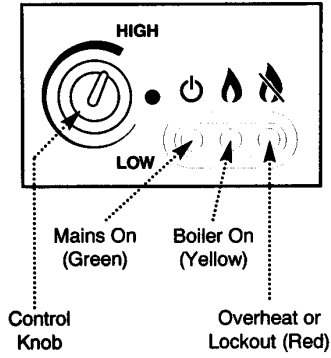

Please Check Following Points Before Going Through The Fault Finding Chart.

- Check electrical system earth continuity, short circuit, resistance to earth, fuse failure and a minimum voltage of 195 is present at input connections on boiler, check internal fuse is OK, unit is not in lockout.
- There is an adequate gas supply pressure at the inlet. A minimum pressure of 18.1 mb is required at the inlet.
- All isolating valves are open and both the boiler and the system are vented.
- Check installation is correct, including the flue system.

IMPORTANT
 If the system requirements are greater than 23.45 kW (80,000 Btu/h), the appliance can be uprated to 33.76 kW (100,000 Btu/h). See section 8.8 for details.

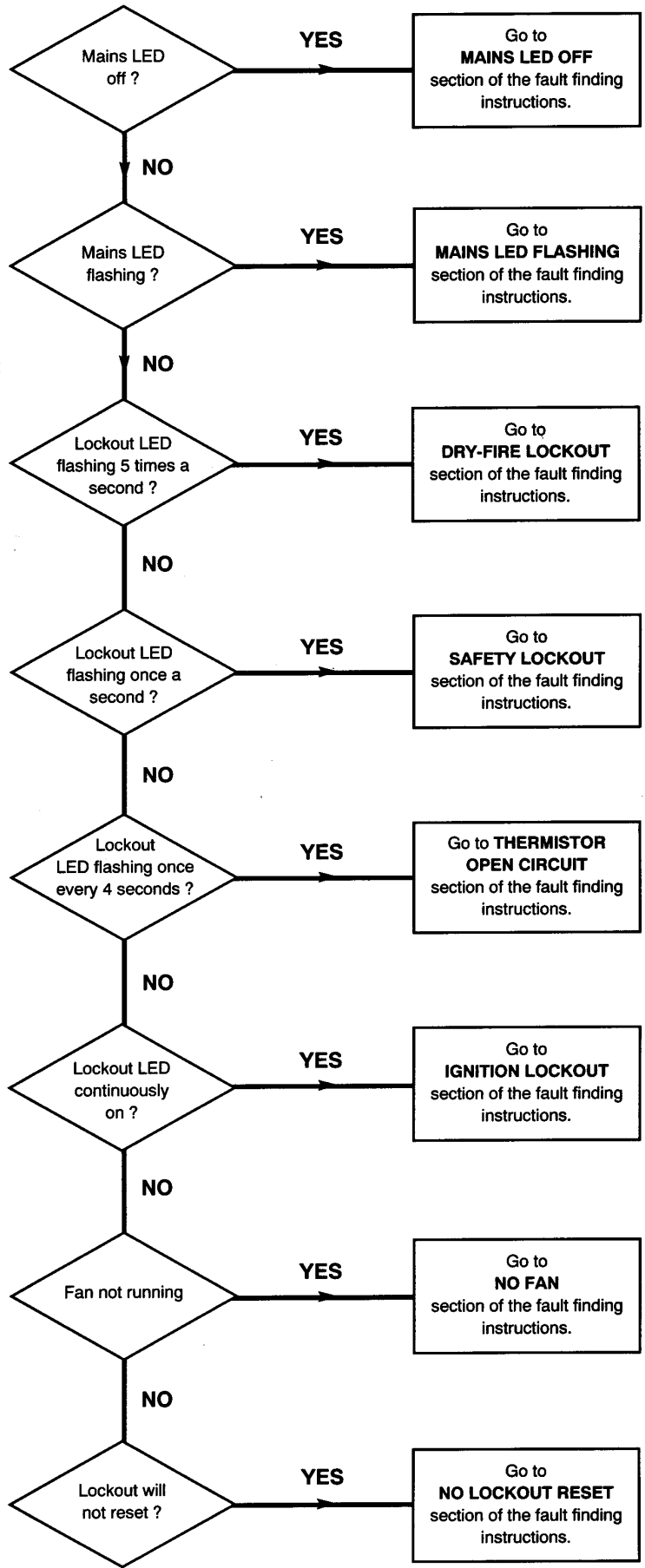

Mains LED Off

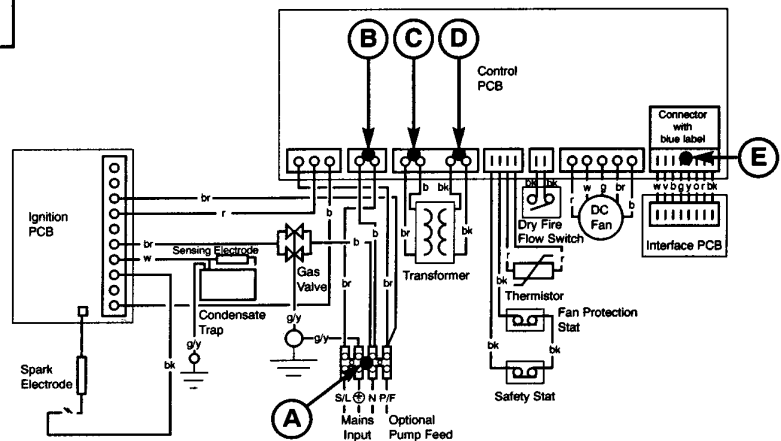
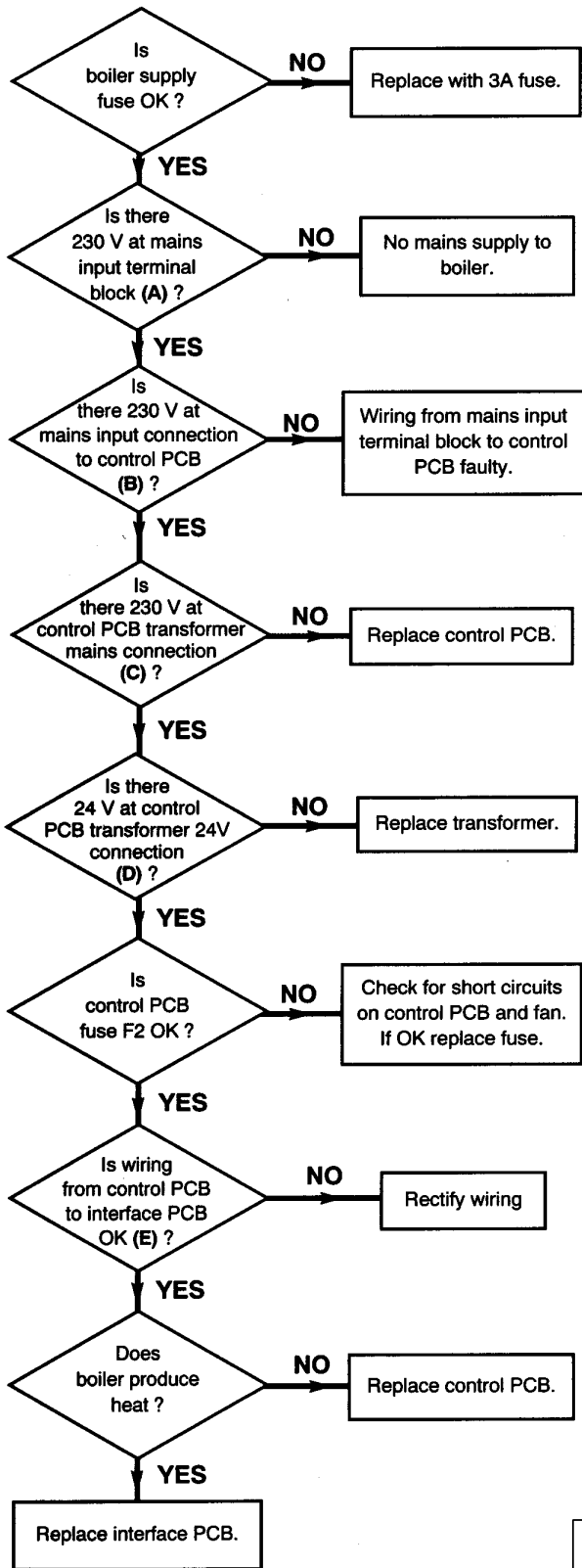

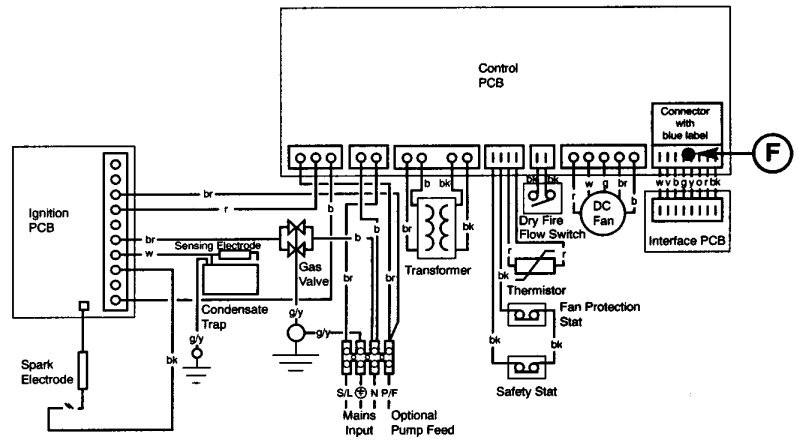
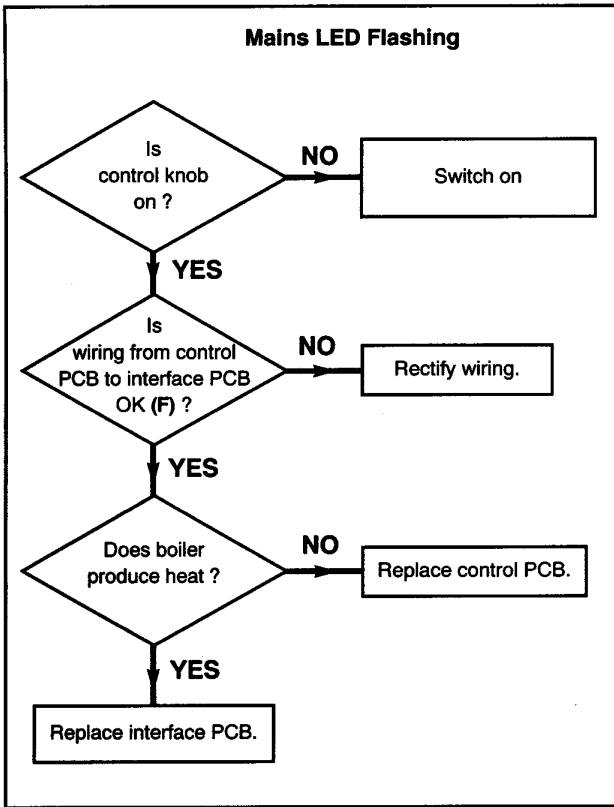

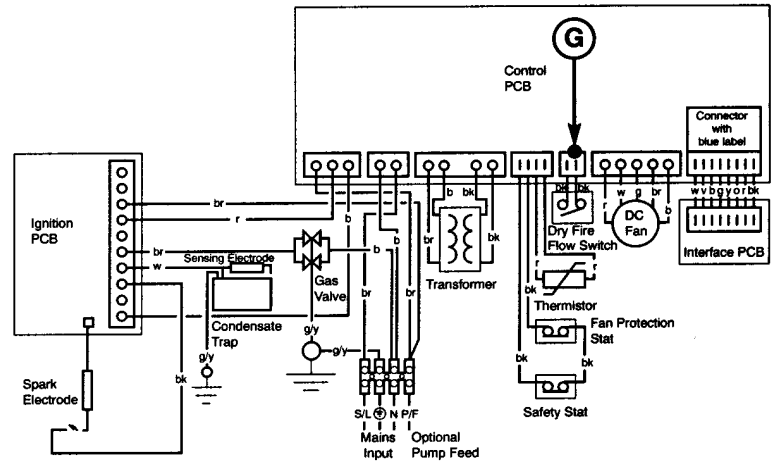
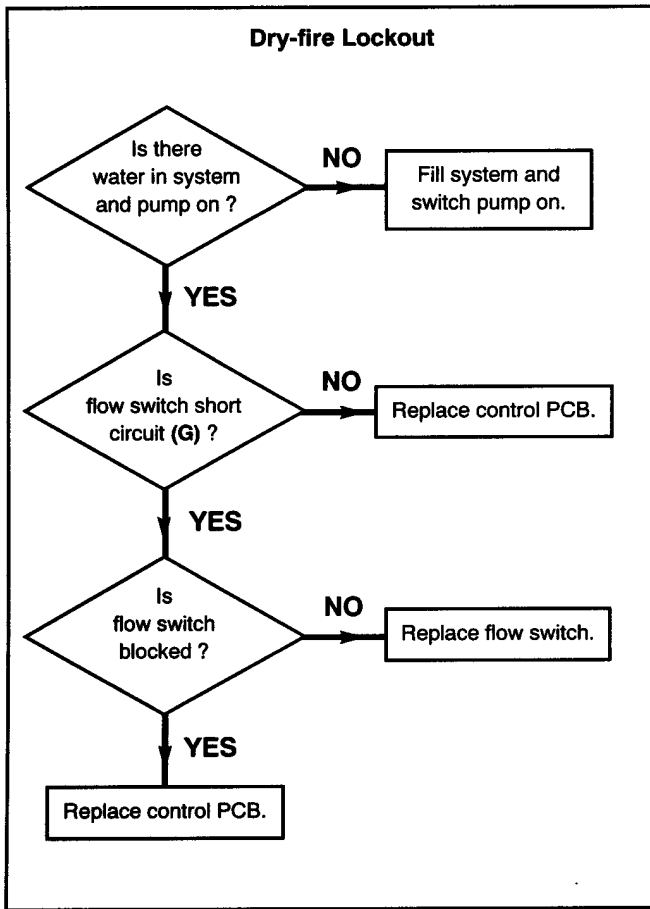

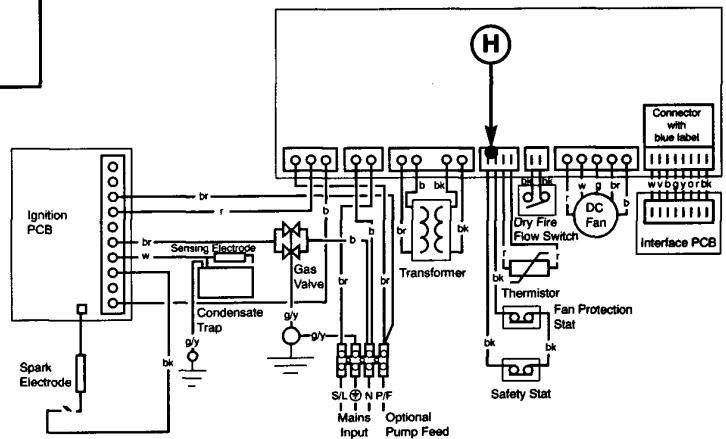
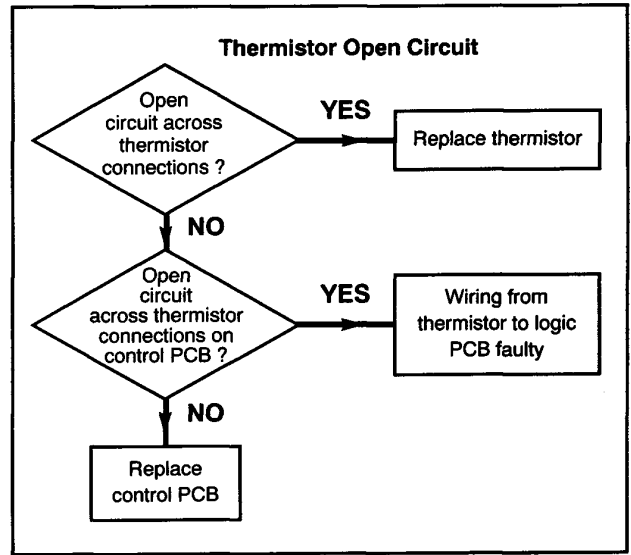
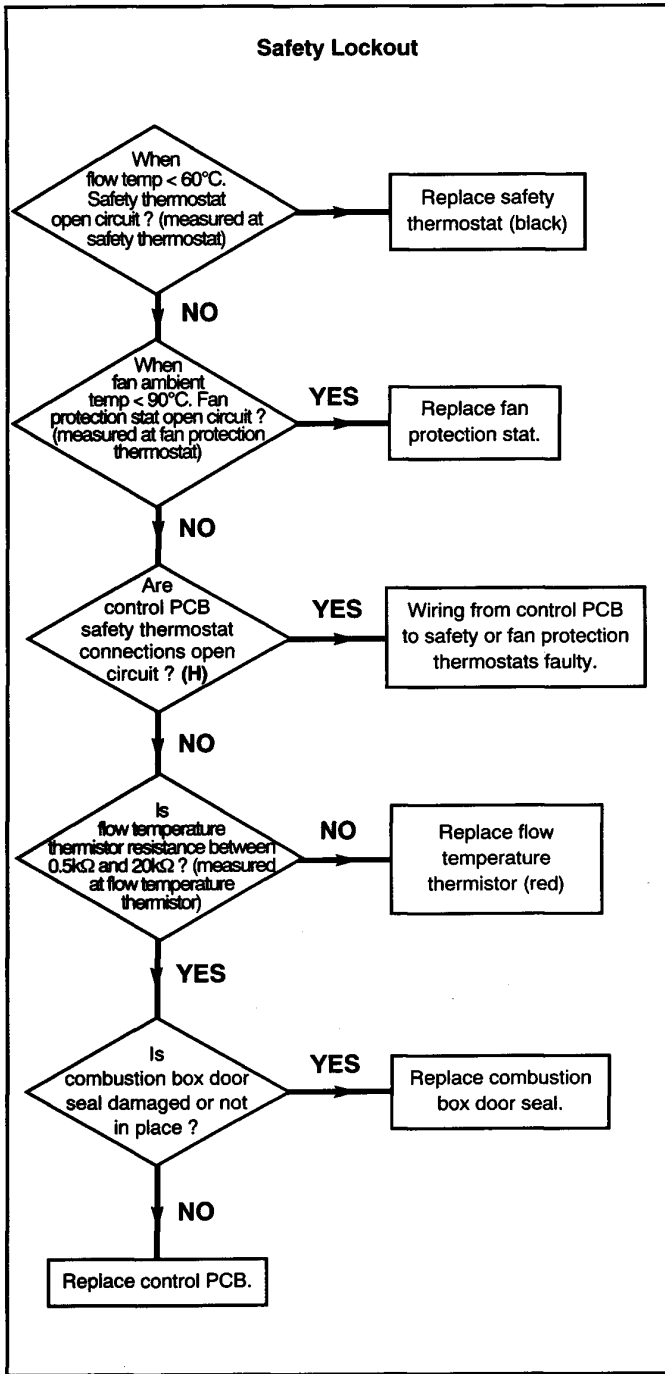

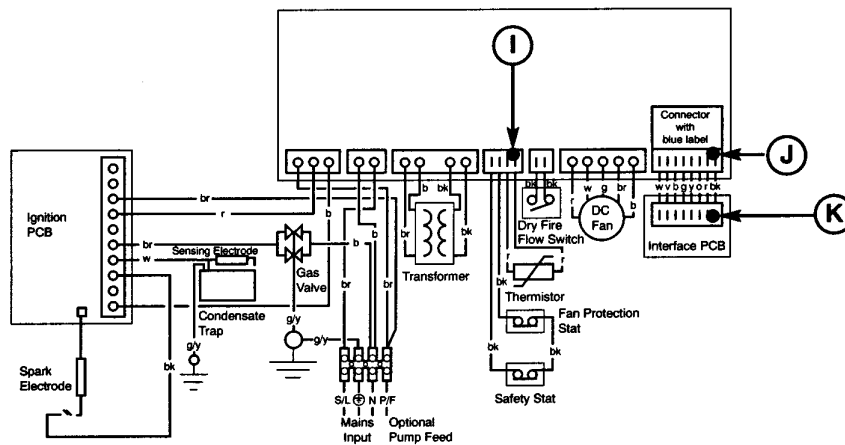
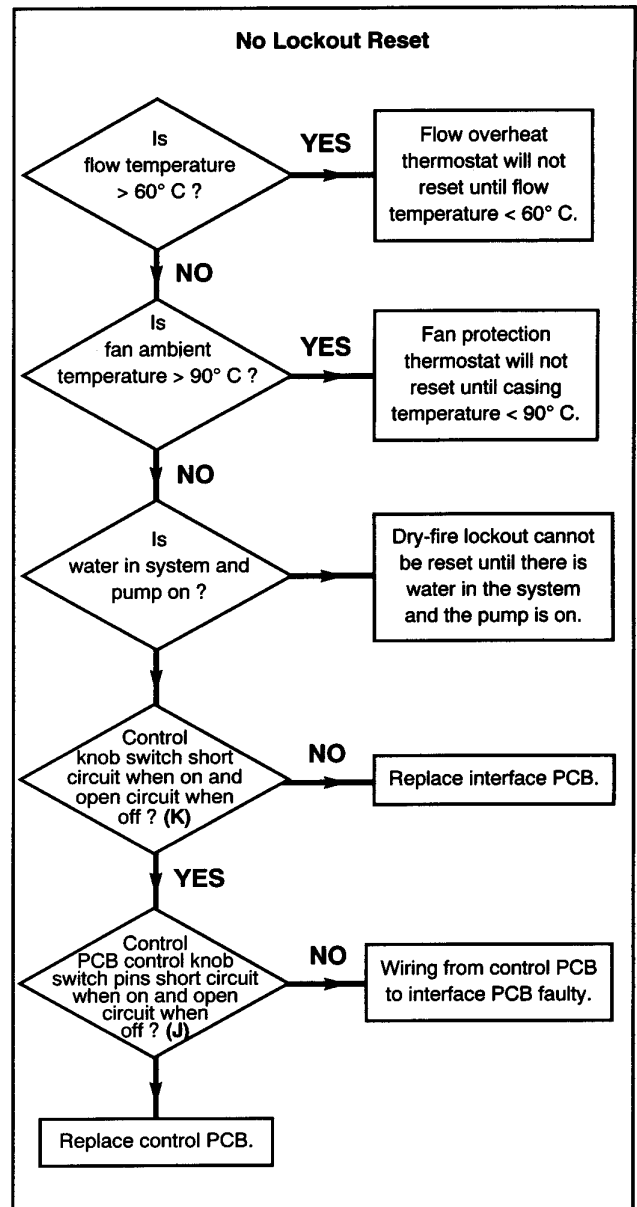
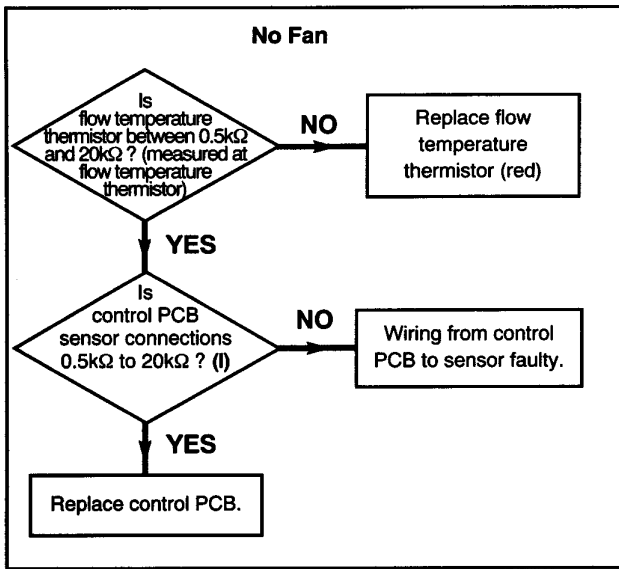

Ignition Lockout

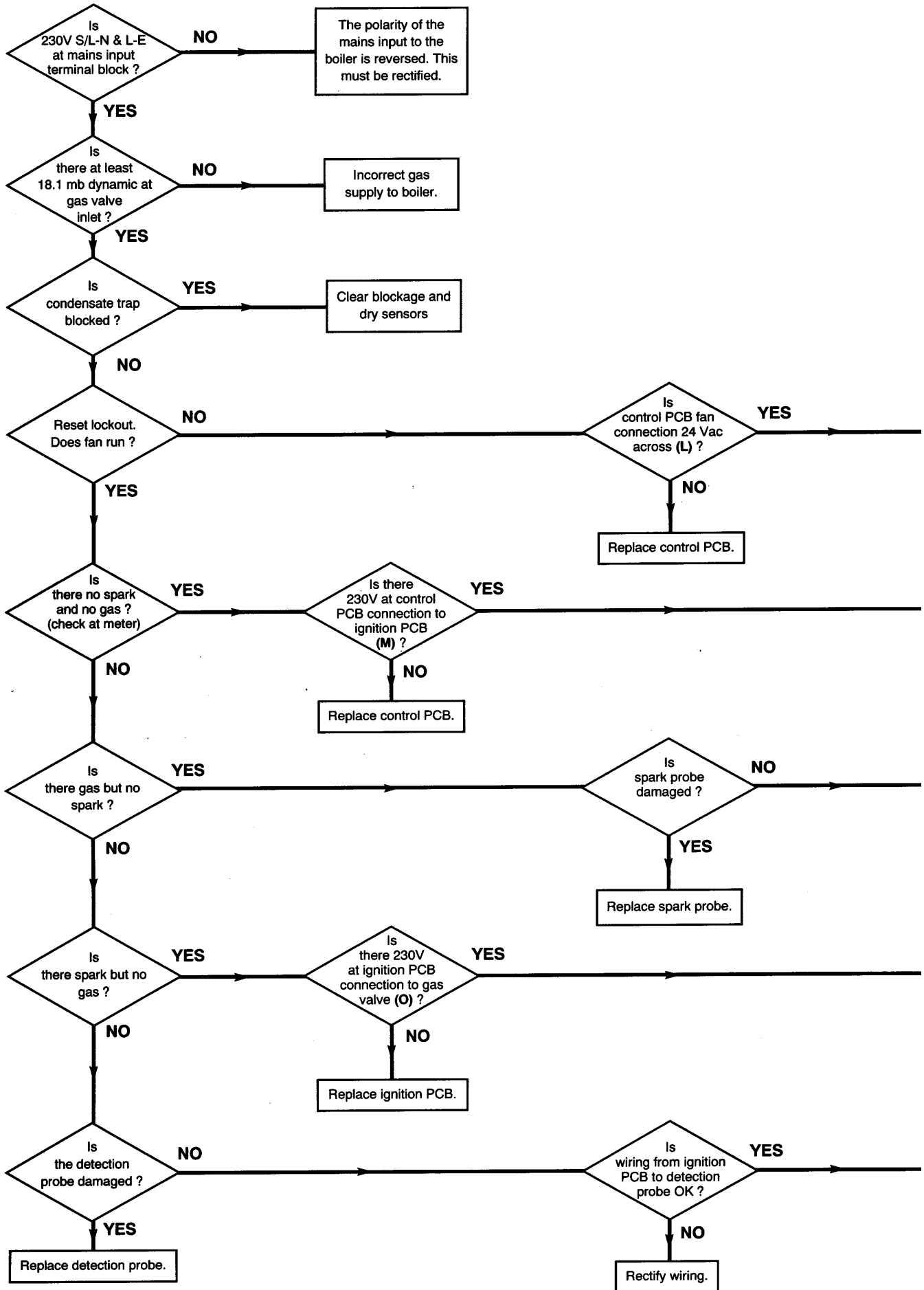

15.0 Fault Finding – page 43

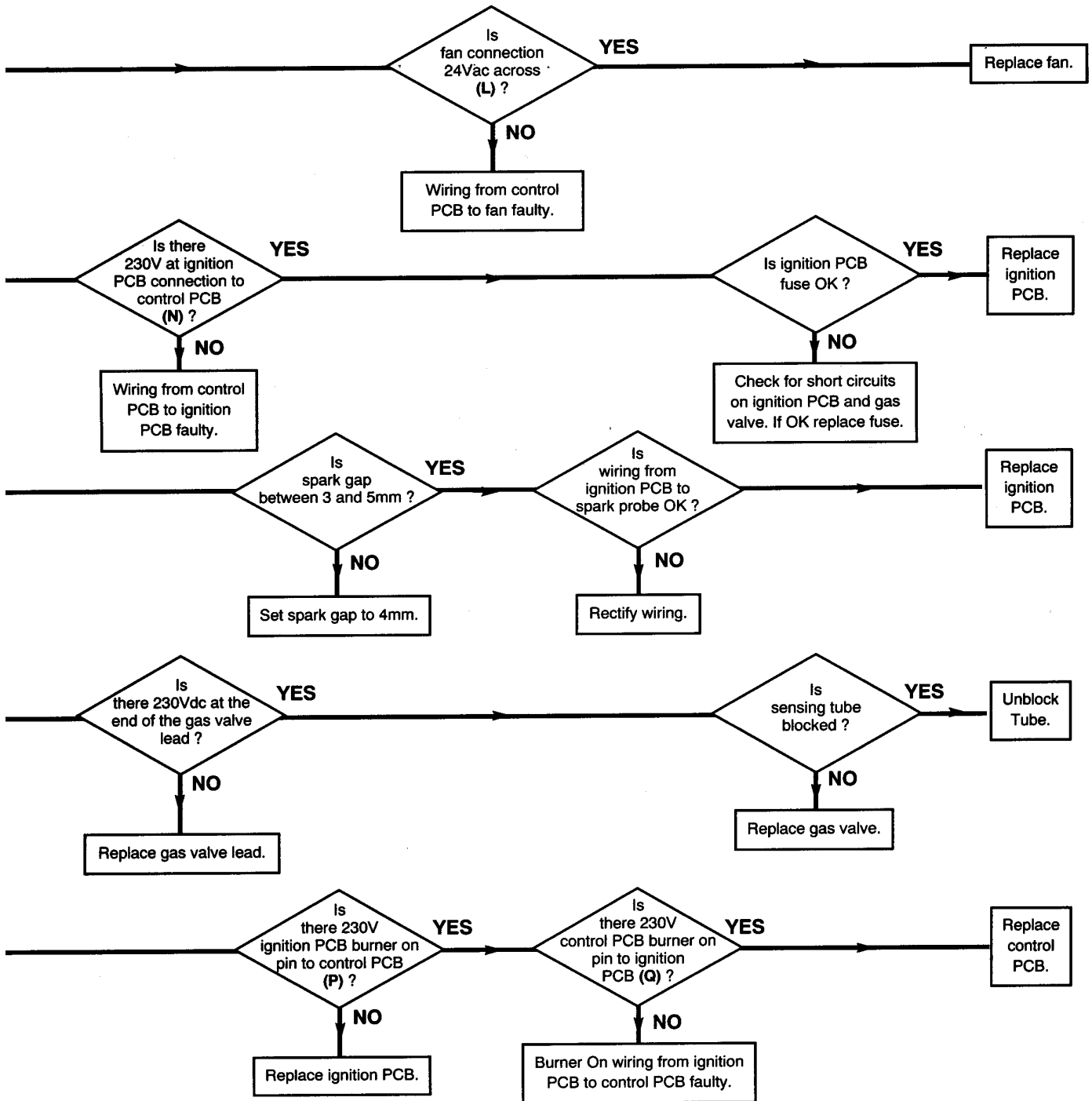
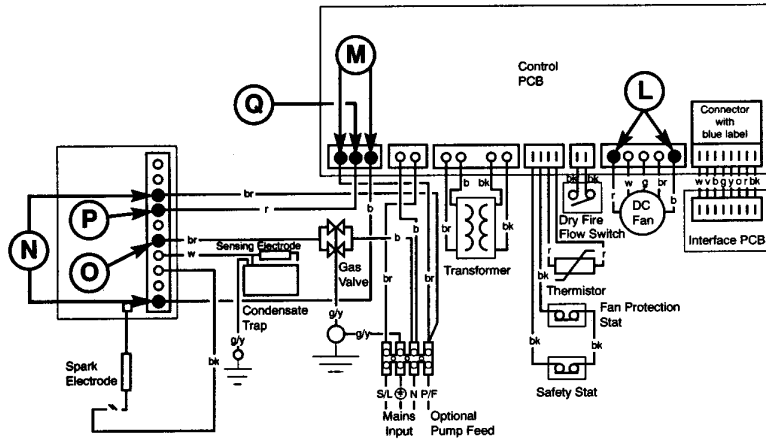

For General Enquiries
+44 (0)1772 695 555

For After Sales Service
+44 (0)1772 695 505

For Technical Enquiries
+44 (0)1772 695 504

BAXI

Baxi Limited
Browndge Road
Bamber Bridge Preston
Lancashire
PR5 6SN
www.baxi.com